



Black Point Quarry Project  
Municipality of the District of Guysborough, NS

Environmental Impact Statement

PART 1 Sections 1-5

Vulcan Materials Company

February 2015

**TABLE OF CONTENTS PART 1 (Sections 1-5)**

<b>1.0</b>	<b>PROJECT INTRODUCTION</b>	<b>5</b>
1.1	Report Organization	5
1.2	Project Overview	6
1.3	Project Location	9
1.4	Geographical Setting	13
1.5	Ecological Overview	15
1.6	Participants in the Environmental Assessment	16
	1.6.1 Proponent	16
	1.6.2 Corporate Information	16
	1.6.3 Safety Health and Environmental Policy	18
	1.6.4 Environmental Consultants	19
	1.6.5 Aboriginal Groups	20
	1.6.6 Community and Environmental Organisations	21
1.7	Project Schedule	23
1.8	Purpose of the Project	23
1.9	Benefits of the Project	24
<b>2.0</b>	<b>REGULATORY FRAMEWORK</b>	<b>26</b>
2.1	Federal	26
	2.1.1 Canadian Environmental Assessment Act (CEAA 2012)	26
	2.1.2 Canadian Environmental Protection Act 1999	26
	2.1.3 Fisheries Act	27
	2.1.4 Migratory Birds Convention Act, 1994	27
	2.1.5 Species at Risk Act	27
	2.1.6 Canada Shipping Act, 2001	28
	2.1.7 Oceans Act	28
	2.1.8 Navigation Protection Act	28
2.2	Provincial	28
	2.2.1 Environmental Assessment	28
	2.2.2 Harmonization	29
	2.2.3 Resource Management Initiatives	29
	2.2.4 Permits and Authorizations	30
2.3	Municipal	32
2.4	Policies and Guidelines	32
2.5	First Nations	34
<b>3.0</b>	<b>PROJECT DESCRIPTION</b>	<b>35</b>
3.1	OVERVIEW OF PROJECT COMPONENTS AND SITE LAYOUT	35
	3.1.1 Access Road	37
	3.1.2 Open Pit Quarry	37
	3.1.3 Processing Plant	50
	3.1.4 Stockpiles, Overburden and Crusher Fines	65
	3.1.5 Administrative Buildings	65
	3.1.6 Transmission Line Tie In	65
	3.1.7 Marine Terminal	66
	3.1.8 Waste Water Treatment System (Other Utilities)	71
3.2	CONSTRUCTION PHASE	71
	3.2.1 Construction Activities	71

3.2.2	<i>Geotechnical Investigations and ARD</i>	72
3.2.3	<i>Site Preparation, Cut and Fill, Blasting</i>	73
3.2.4	<i>Access Road and Transmission Tie-in</i>	77
3.2.5	<i>Processing Plant and Laydown Areas</i>	77
3.2.6	<i>Marine Terminal</i>	78
3.2.7	<i>Construction Water Use and Water Management</i>	79
3.2.8	<i>Construction Related Noise</i>	79
3.2.9	<i>Construction Related Traffic</i>	79
3.2.10	<i>Construction Schedule</i>	80
3.3	<b>OPERATIONS PHASE</b>	80
3.3.1	<i>Quarry Operation</i>	80
3.3.2	<i>Processing Plant Operation</i>	84
3.3.3	<i>Operational Water Requirements</i>	84
3.3.4	<i>Offloading to Ships</i>	85
3.3.5	<i>Liquid Fuel Delivery and Storage</i>	85
3.3.6	<i>Hazardous Materials Management</i>	86
3.3.7	<i>Wastewater Management</i>	86
3.3.8	<i>Other Waste</i>	88
3.3.9	<i>Operation Related Noise and Light</i>	88
3.3.10	<i>Air Emissions</i>	90
3.3.11	<i>Marine Vessel Operations</i>	92
3.3.12	<i>Emissions to Atmosphere from Marine Operations</i>	95
3.4	<b>DECOMMISSIONING PHASE</b>	97
3.4.1	<i>Transfer of Ownership and Control</i>	97
3.4.2	<i>Rehabilitation Plan</i>	98
3.4.3	<i>Site Description at Closure</i>	99
3.4.4	<i>Reclamation Objectives</i>	99
3.4.5	<i>Reclamation Goals</i>	100
3.4.6	<i>Removal of Equipment and Infrastructure</i>	100
3.4.7	<i>Removal of the Marine Terminal</i>	101
3.4.8	<i>Site Rehabilitation</i>	101
3.4.9	<i>Reclamation Phasing Timeline</i>	102
3.5	<b>ACCIDENTS AND MALFUNCTIONS</b>	104
3.5.1	<i>Fuel and Hazardous Materials Spills</i>	104
3.5.2	<i>Erosion and Sediment Control Failure</i>	106
3.5.3	<i>Vehicle and Vessel Collision</i>	107
3.5.4	<i>Fire</i>	107
3.5.5	<i>Health, Safety and Environmental Management</i>	108
4.0	<b>ALTERNATIVES TO THE PROJECT</b>	112
4.1	<i>Do Nothing Alternative</i>	112
4.2	<i>Assessment Methodology</i>	112
4.3	<i>Alternative Quarry Locations</i>	113
4.4	<i>Rock Extraction Method</i>	114
4.5	<i>Development and Transportation</i>	114
4.6	<i>Marine Terminal Locations</i>	115
4.7	<i>Marine Terminal Construction Methods</i>	117
4.8	<i>Stockpile Locations</i>	119
4.9	<i>Waste Management Facilities</i>	119
4.10	<i>Electrical Supply</i>	121

4.11	The Preferred Approach.....	122
5.0	ENVIRONMENTAL EFFECTS ASSESSMENT METHODOLOGY.....	127
5.1	Overview.....	127
5.2	Application of the Precautionary Approach.....	127
5.3	Valued Components Selection.....	128
5.4	Likely Project-Environment Interactions.....	129
5.5	Project Boundaries.....	135
5.5.1	Temporal Boundaries.....	135
5.5.2	Spatial Boundaries.....	135
5.5.3	Technical Boundaries.....	138
5.5.4	Administrative Boundaries.....	138
5.6	Impact Prediction.....	138
5.7	Environmental Effects Assessment.....	139
5.8	Mitigation and Residual Effects.....	139
5.9	Residual Effects and the Determination of Significance.....	142
5.10	Cumulative Environmental Effects.....	143
5.11	Follow Up and Monitoring.....	144
5.12	Effects of the Environment on the Project.....	144
5.13	Description of the Retained VCs.....	145

**TABLES PART 1 (Sections 1-5)**

Table 1.1:	Black Point Quarry Property Identification Numbers.....	9
Table 1.2:	Proposed Boundary Coordinates.....	11
Table 1.3:	Project Proponent Contact Information.....	16
Table 1.4:	Environmental Consultant Contact Information.....	19
Table 1.5:	Names and Qualifications of the Report Authors.....	20
Table 1.6:	Environmental and Community Organisations.....	22
Table 1.7:	Generalized Project Schedule.....	23
Table 2.1:	Anticipated Key Permitting Requirements.....	31
Table 2.2:	Federal and Provincial Policies and Guidelines.....	33
Table 3.1:	Construction to Operation Schedule.....	82
Table 3.2:	Standard Shot Design.....	83
Table 3.3:	Total Criteria Pollutant Emissions from Quarry and Processing Plant (tonnes/year).....	91
Table 3.4:	Tier I - Direct GHG Emissions Quarry, Processing Plant and Loadout.....	91
Table 3.5:	Tier II - Indirect GHG Emissions for Electric Power Usage.....	92
Table 3.6:	Tier I - Direct GHG Emissions from Vessel Operations at Marine Terminal.....	96
Table 3.7:	Emissions for Total Annual Vessel Haulage (To/From Canadian Economic Zone Edge).....	96
Table 3.8:	Vessel Operation GHG Analysis.....	97
Table 3.9:	Reclamation Phasing Timeline.....	102
Table 4.1:	Summary of the Alternative Means of Undertaking the Project.....	123
Table 5.1:	List of Provisional Valued Components.....	129
Table 5.2:	Potential Project Interactions with Valued Components (VCs).....	131
Table 5.3:	Basis for Selection of VCs.....	133
Table 5.4:	Spatial Boundary Assessment by Valued Component.....	137
Table 5.5:	Residual Environmental Effects Assessment Matrix for [Name of VC].....	141
Table 5.6:	Definitions for Levels of Magnitude.....	143



**FIGURES PART 1 (Sections 1-5)**

<b>Figure 1.0-1: Site Location .....</b>	<b>8</b>
<b>Figure 1.0-2: Property Boundaries.....</b>	<b>10</b>
<b>Figure 1.0-3: Marine Terminal .....</b>	<b>12</b>
<b>Figure 1.0-4: Location of Nearest Residences .....</b>	<b>14</b>
<b>Figure 3.0-1: Site Components.....</b>	<b>36</b>
<b>Figure 3.0-2: Pre-mining .....</b>	<b>39</b>
<b>Figure 3.0-3: End of Year 1 .....</b>	<b>40</b>
<b>Figure 3.0-4: End of Year 2 .....</b>	<b>41</b>
<b>Figure 3.0-5: End of Year 3.....</b>	<b>42</b>
<b>Figure 3.0-6: End of Year 4.....</b>	<b>43</b>
<b>Figure 3.0-7: End of Year 5.....</b>	<b>44</b>
<b>Figure 3.0-8: 49.9 MT Mined .....</b>	<b>45</b>
<b>Figure 3.0-9: 99.6 MT Mined .....</b>	<b>46</b>
<b>Figure 3.0-10: 150.2 MT Mined .....</b>	<b>47</b>
<b>Figure 3.0-11: 251.4 MT Mined .....</b>	<b>48</b>
<b>Figure 3.0-12: 403.3 MT Mined .....</b>	<b>49</b>
<b>Figure 3.0-13: Phase 1, 2, 3 Flow Diagrams .....</b>	<b>51</b>
<b>Figure 3.0-14: Phase 4 Flow Diagram .....</b>	<b>52</b>
<b>Figure 3.0-15: Phase 5 Flow Diagram .....</b>	<b>53</b>
<b>Figure 3.0-16: Phase 1 Layout.....</b>	<b>55</b>
<b>Figure 3.0-17: Phase 2 Layout.....</b>	<b>57</b>
<b>Figure 3.0-18: Phase 3 Layout.....</b>	<b>59</b>
<b>Figure 3.0-19: Phase 4 Layout.....</b>	<b>61</b>
<b>Figure 3.0-20: Phase 5 Layout.....</b>	<b>63</b>
<b>Figure 3.0-21: Plant Elevations .....</b>	<b>64</b>
<b>Figure 3.0-22: Site Layout Plan – Marine Terminal .....</b>	<b>67</b>
<b>Figure 3.0-23: General Arrangement .....</b>	<b>68</b>
<b>Figure 3.0-24: Section Views.....</b>	<b>69</b>
<b>Figure 3.0-25: Slewing Rail Pier .....</b>	<b>70</b>
<b>Figure 3.0-26: Cut and Fill Areas.....</b>	<b>75</b>
<b>Figure 3.0-27: Cut and Fill Sample Locations .....</b>	<b>76</b>
<b>Figure 3.0-28: “Panamax” Size Ship.....</b>	<b>93</b>
<b>Figure 3.0-29: Proposed Shipping Route .....</b>	<b>94</b>
<b>Figure 3.0-30: Potential End Use of the Quarry .....</b>	<b>103</b>
<b>Figure 4.0-1: Alternative Marine Terminal Locations.....</b>	<b>116</b>
<b>Figure 4.0-2: Marine Terminal Design (Rubble Mound and Caisson).....</b>	<b>118</b>
<b>Figure 4.0-3: Alternative Crusher Fines Storage Areas (Orange).....</b>	<b>120</b>
<b>Figure 4.0-4: Preferred Crusher Fines Storage Areas (Blue) .....</b>	<b>121</b>

## 1.0 PROJECT INTRODUCTION

### 1.1 Report Organization

This Environmental Impact Statement (EIS) is organized to reflect the process by which the environmental assessment was conducted. The EIS begins with an introduction to the Project and Proponent. This is followed by a description of the regulatory framework within which the Project will be assessed, a detailed description of the construction, operation, and decommissioning of the Project, a description of alternatives that were considered during Project planning, and a description of the environmental effects methodology that was used.

These sections are followed by a description of the biophysical environment in which the Project will be constructed and operated. Information from these sections is then used to assess the effects of the Project on the biophysical and human environments and identify measures that will be taken to limit or eliminate those effects. Monitoring programs that will help determine the accuracy of the predicted residual impacts are also presented.

A separate section describes the public, First Nation and stakeholder engagement programs that have been, and will continue to be, undertaken. The report closes with a summary describing the effects of the Project on the environment, the effects of the environment on the Project and the cumulative effects from other anticipated developments in the region. In more detail:

**Section 1.0 Project Introduction** introduces the Project and Proponent and provides background information on the Project. Project location, scope and schedule are presented. Project activities are described in a general way.

**Section 2.0 Regulatory Framework** describes the primary federal and provincial laws and regulations that mandate and guide the environmental assessment process, as well as the principal laws, regulations and policies that the Project is subject to.

**Section 3.0 Project Description** provides a comprehensive description of the Project during all phases of development. It lists the project components and structures, outlines the layout of the various facilities and infrastructure, describes site operations and lists emissions and discharges during construction, operation and decommissioning.

**Section 4.0 Alternatives to the Project** describes alternative means of carrying out the Project that were considered during Project planning, and why the current version of the Project is preferred.

**Section 5.0 Environmental Effects Assessment Methodology** describes the assessment methodology employed for the EIS. The methodology outlines how each “Valued Component” or VC was chosen, lists probable project-environment interactions, and describes the size of the different study areas selected for the EIS.

**Section 6.0 Existing Environment** describes the physical, terrestrial, marine and socio-economic characteristics of the study areas. A total of thirteen subject categories are described, ranging from surface and groundwater resources, through marine and terrestrial habitat to First

Nation interests, shipping, and commercial fisheries. This section provides the background or context to Project development.

**Section 7.0 Environmental Effects Assessment** provides the results of the environmental effects assessment for each VC selected in Section 5.0. Mitigation measures that will be applied to limit or eliminate project effects on the human and ecological environments are also described, and any residual effects or impacts are listed.

**Section 8.0 Effects of the Environment on the Project** describes the possible effects of severe weather, climate change, and other events on the Project.

**Section 9.0 Cumulative Effects** considers other anticipated projects in the region and describes how effects from each of these other projects may combine to cause more intense or more regional effects than the Black Point Project alone.

**Section 10.0 Proposed Compliance and Effects Monitoring Programs** summarizes information first presented in the Effects Assessment (Section 7.0) into a single location so that all proposed follow-up monitoring programs can be reviewed together. The monitoring programs are intended to verify the nature and scope of the predicted impacts, or the lack of impacts, during Project construction and operation.

**Section 11.0 Consultation and Engagement Programs** lists and describes the various outreach efforts the Proponent has made to the different stakeholder communities over the course of the environmental assessment.

**Section 12.0 Assessment Summary and Conclusion** summarizes the findings of the EIS, and includes a discussion of residual Project-related effects on the environment, probable effects of the environment on the Project and cumulative effects.

A series of technical reports and other supporting information are contained in the appendices.

## 1.2 Project Overview

Vulcan Materials Company (Vulcan), a U.S.-based aggregate producer and Morien Resources Corporation (Morien), a Nova Scotia-based resource development company, have jointly prepared this Environmental Impact Statement (EIS), which outlines the proposed development, operation, and decommissioning and abandonment of a hard rock quarry and marine terminal at Black Point in Guysborough County, Nova Scotia (**Figure 1.0-1**). Black Point Aggregates Inc., a wholly owned subsidiary of Vulcan Materials Company, is the named Proponent of the Project. Following the environmental assessment process, Black Point Aggregates Inc. will develop and operate the quarry and marine terminal.

The anticipated average annual production rate will exceed 1.0 million tonnes (MT) with a peak production rate of 7.5 MT per year, should market conditions warrant this production rate. The Project is anticipated to have capital costs on the order of US\$80-\$110 million and will be a significant employer in Guysborough County throughout the expected 50+ year lifespan of the quarry. The total property is 354.5 ha; the finished quarry will occupy approximately 180 ha while the processing plant, administration and stockpile areas together will occupy approximately 28 ha.

This EIS has been prepared to obtain approval pursuant to the federal *Canadian Environmental Assessment Act, 2012* and, at the same time, approval for a Class I undertaking pursuant to the provincial *Environmental Assessment Regulations* made under the Nova Scotia *Environment Act*.

The site for the proposed Project was selected primarily due to the quantity and superior quality of granite rock, combined with thin to non-existent overburden. Rock reserves in the proposed quarry are estimated at more than 400 MT. Also, the proposed quarry is adjacent to deep water, which is sheltered and ice-free. This enables the construction and safe operation of a deep water marine terminal for aggregate shipment. Aggregate from the quarry will be transported in bulk carrier ships, as large as Panamax-sized (up to 70,000 deadweight tonnage or DWT), to ports along the eastern and Gulf coast markets of the U.S.

Electrical power for buildings and equipment (pumps, conveyors, crushers, screens, and ship loading) will be supplied through a tie-in to the existing Nova Scotia Power Inc. (NSPI) electrical transmission line that forms the southern Property boundary. A single pole, 2.5 km long high voltage transmission line (20 m wide right of way) will bring power to the site. A transformer sub-station will be required to reduce the voltage for the quarry.

Other utilities will include domestic water supply and sewage management or disposal system to facilitate the needs of on-site workers. Entrance to the quarry will be via an access road to be constructed from provincial Route 16 (Marine Drive).

At this time, no public funding is being sought to undertake this Project.





- LEGEND**
- Building
  - ▭ Property Boundary
  - ▭ Wilderness Area
  - ▭ NSDNR Wetland
  - ▭ Waterbody
  - ▭ Watercourse
  - ▭ Contour (5m)
  - ▭ Utility Line
  - ▭ Designated Water Supply Area
  - ▭ Natural Watershed Municipal Surface Water Supply
  - ▭ Operational Non-Designated Parks and Reserves

Chedabucto Bay

**Canso Islands National Historic Site of Canada**

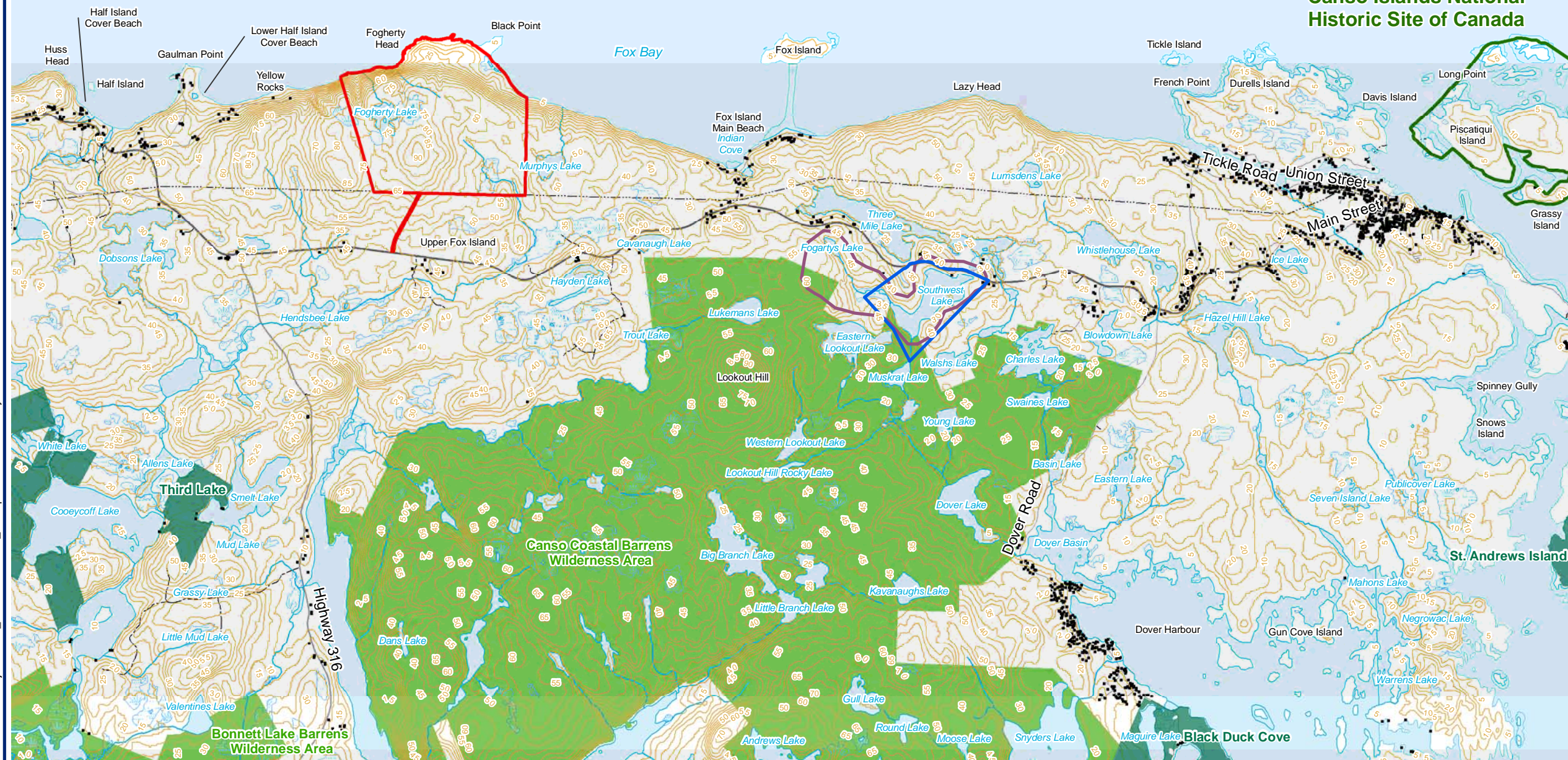

SCALE: 1:60,000  
WHEN PLOTTED CORRECTLY AT 11 x 17  
NAD 1983 UTM Zone 20N

**NOTES**  
This map is for conceptual purposes only and should not be used for navigational purposes.

Basedata: Nova Scotia Natural Resources, downloaded, June 2014; Orthoimagery from GeoNOVA, 2007.

**MORIEN RESOURCES AND VULCAN MATERIALS**

BLACK POINT QUARRY

SITE LOCATION

October 24, 2014	Rev 1.0	Figure No.
Project No. 210.05913.00000		<b>1.0-1</b>



N:\Markham\Project Files\2014\210.05913\_Blackpoint\3.Data & Analysis\2.GIS\1.MXD\3.WRK\G210\_05913\_Site Location.mxd



### 1.3 Project Location

The lands to be developed are owned by the Municipality of the District of Guysborough (MODG) and will be leased to the Proponent. The property is currently undeveloped and is zoned Industrial Heavy I-2 (pers. comm. D. Torrey, 2014). Permitted uses for this zoning includes, among other activities, “rock quarry operation or open-pit mines from which rocks or minerals are extracted” (MODG 2013). The approximate center of the Project site is located at:

45°21'13.25"N

61°08'56.15"W

The municipal land designated for the Project consists of properties assembled through a land exchange with the Province and through expropriation of private lands. The property reference numbers are provided in Table 1.1.

**Table 1.1:  
 Black Point Quarry Property Identification Numbers**

<b>Assembled Through Land Exchange w/ Province</b>	<b>Assembled Through Expropriation</b>
1: 35212521	7: 35044056
2: 35212497	8: 35214014
3: 35212505	9: 35214022
4: 35213990	10: 35093210
5: 35212513	
6: 35212539	

The generalized property boundaries are shown on **Figures 1.0-1** and **1.0-2**. Table 1.2 provides coordinates for the four corners of the proposed Project area and the submerged Crown Land Lease that will host the marine terminal. The submerged Crown Land Lease has not yet been granted. The land parcel that includes Black Point itself is Crown land; this parcel is not included in the Project.

The provincial Crown Land in the marine environment needed for the marine terminal has not been previously used as a marine terminal and has not been so designated by the MODG. The Proponent has worked with the MODG and has made application to the Nova Scotia Department of Natural Resources (NSDNR) to lease a portion of the seabed extending from the ordinary high water mark north approximately 300 m to allow for construction and operation of the terminal, shown on **Figure 1.0-3**.



N:\Markham\Project Files\2014\210.05913\_Blackpoint\3\_Data & Analysis\2\_GIS\1\_MXD\3.WRK\210\_05913\_PropertyBoundary.mxd

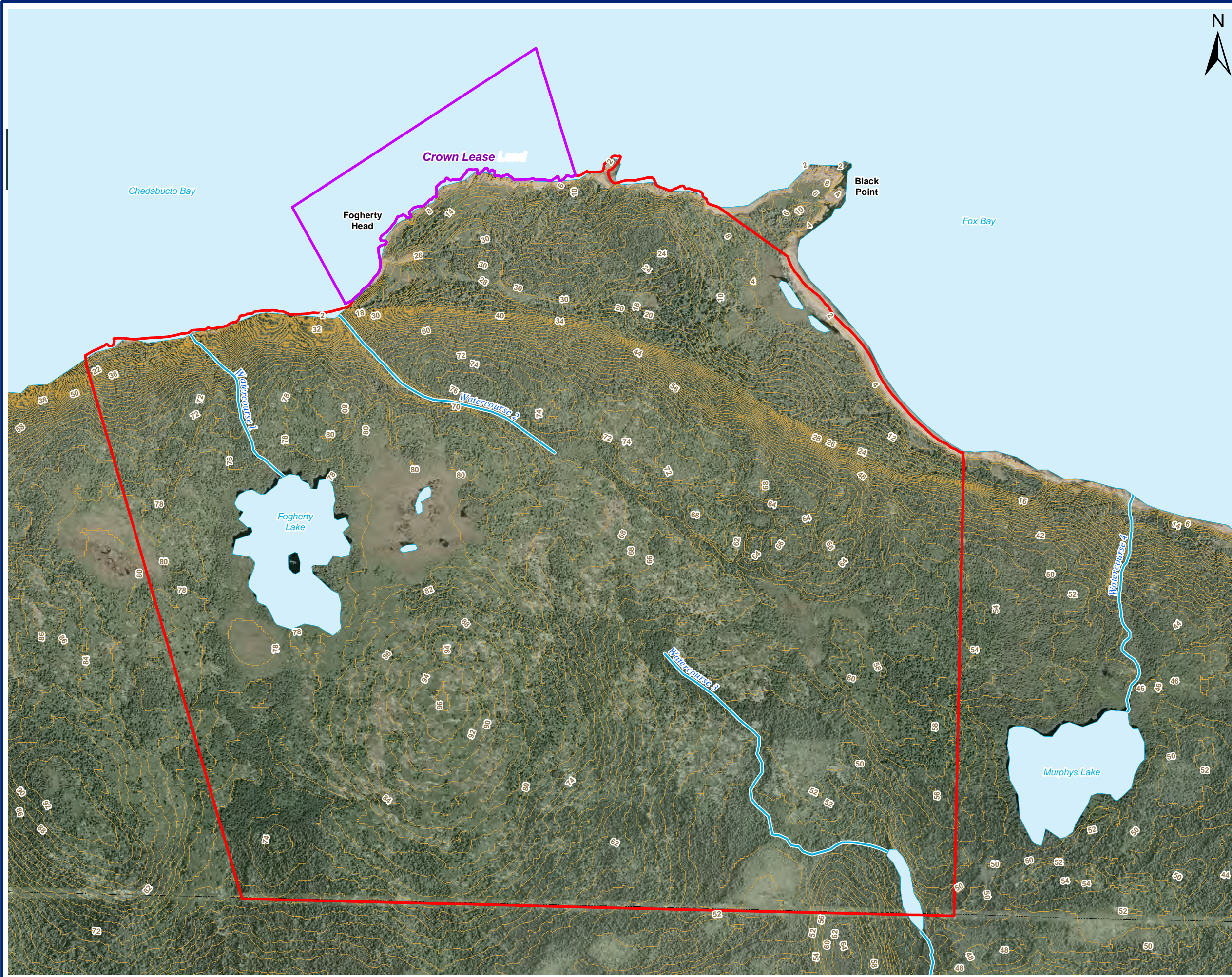

**LEGEND**

- Property Boundary
- Crown Lease Land
- Waterbody
- Watercourse
- LIDAR Contour (2m)
- Utility Line

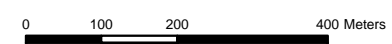

SCALE: 1:10,000  
WHEN PLOTTED CORRECTLY AT 11 x 17  
NAD 1983 UTM Zone 20N

**NOTES**

This map is for conceptual purposes only and should not be used for navigational purposes.

Basedata: Nova Scotia Natural Resources, downloaded, June 2014; Orthoimagery from GeoNOVA, 2007.

**MORIEN RESOURCES  
AND VULCAN MATERIALS**

BLACK POINT QUARRY

PROPERTY BOUNDARIES

October 22, 2014	Rev <b>1.0</b>	Figure No.
Project No. 210.05913.00000		<b>1.0-2</b>



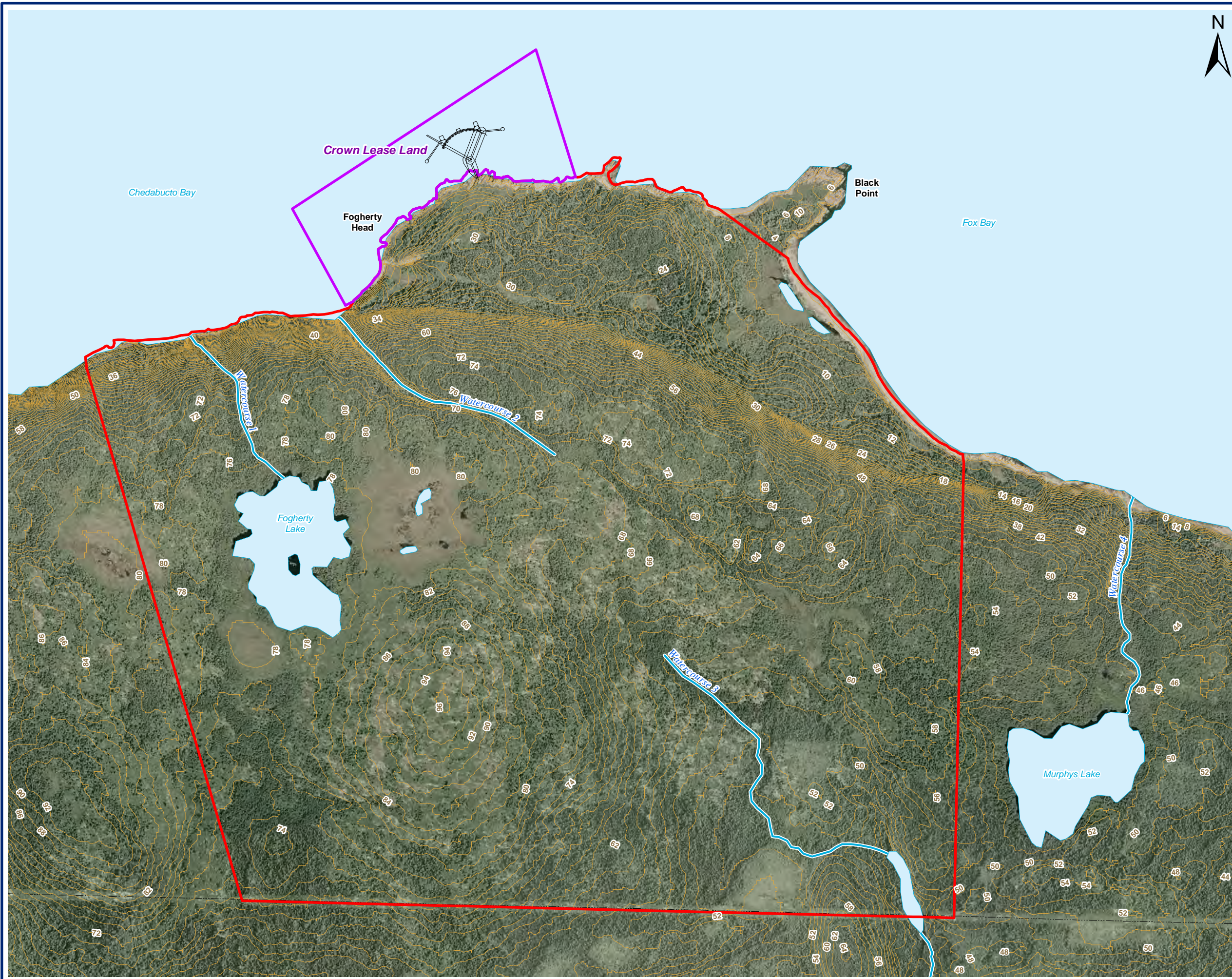

**Table 1.2:  
Proposed Boundary Coordinates**

Boundary Location	Easting	Northing
Terrestrial Property		
North West Corner	643573.480	5023895.438
South West Corner	644005.711	5022431.120
South East Corner	645930.498	5022389.912
North East Corner	645955.893	5023627.756
Submerged Crown Land Lease		
North West Corner	644130.37	5024312.49
South West Corner	644275.16	5024050.04
South East Corner	644900.62	5024394.53
North East Corner	644791.83	5024744.29



N:\Markham\Project Files\2014\210.05913\_Blackpoint\3\_Data & Analysis\2\_GIS\1\_MXD\3.WRK\210\_05913\_MarineTerminalLoc.mxd



**LEGEND**

- Property Boundary
- Crown Lease Land
- Waterbody
- Watercourse
- LIDAR Contour (2m)
- Utility Line



SCALE: 1:10,000  
WHEN PLOTTED CORRECTLY AT 11 x 17  
NAD 1983 UTM Zone 20N

**NOTES**

This map is for conceptual purposes only and should not be used for navigational purposes.

Basedata: Nova Scotia Natural Resources, downloaded, June 2014; Orthoimagery from GeoNOVA, 2007.

**MORIEN RESOURCES  
AND VULCAN MATERIALS**

BLACK POINT QUARRY

MARINE TERMINAL LOCATION

October 22, 2014	Rev <b>1.0</b>	Figure No.
Project No. 210.05913.00000		<b>1.0-3</b>





## 1.4 Geographical Setting

The quarry is proposed for a 354.5 ha property located on the south shore of Chedabucto Bay approximately 4.0 km east of Fox Island in Guysborough County, Nova Scotia. The Project is bound to the north by Chedabucto Bay and to the south by a 69 kV power transmission line. No terrestrial federal lands will be used to undertake this project. The nearest federal lands are the Canso Islands National Historic Site of Canada (which includes the Grassy Island Forts site) located approximately 10 km due east of Black Point (**Figure 1.0-1**).

Although the marine terminal will be constructed within the limits of a provincial seabed Crown Land Lease, aggregate shipping will occur on “federal lands” as defined in CEAA 2012 (S.2b). Federal land in this context refers that portion of the ocean claimed by Canada.

The Project site is located on an undulating granite hill with minimal soil cover and overburden. The hill, which has a maximum elevation of approximately 96 m above sea level (asl), is sloped to the north where a cliff is present. The site levels off abruptly at approximately 22 m asl where it gradually grades to the rocky coast. The regional geology consists of Ordovician age metamorphosed sediments of the Halifax and Goldenville formations, intruded by Devonian age granites (Erdene 2011). The granite is the rock that will be quarried and crushed to produce aggregate.

All blasting will occur more than 900 m away from any residential structures. There are no hospitals, retirement hospices, schools or day care centres located within 5 km of the site. Provincial Route 16 (Marine Drive) runs parallel to the southern boundary of the Project site and is located approximately 750 m south of the site. Residential development in the vicinity of the Project is relatively rare, with no residential structures within 500 m of the property line and fewer than seven within 1.0 km of the property boundary (**Figure 1.0-4**). The nearest residence (an abandoned trailer home, for sale as of September 2014) is approximately 700 m west of the property boundary along Half Island Cove Road. A cluster of three residences is located along Route 16 approximately 750 m southwest of the property boundary. In fact, the quarry will not occupy the entire property; quarrying will stop 95 m inside the eastern property boundary, 125 m inside the southern property boundary and 225 m inside the western property boundary (**Figure 1.0-4**).

N:\Markham\Project Files\2014\210.05913\_Blackpoint\3\_Data & Analysis\2\_GIS\1\_MXD\3.WRK\G210\_05913\_NearestResidences.mxd

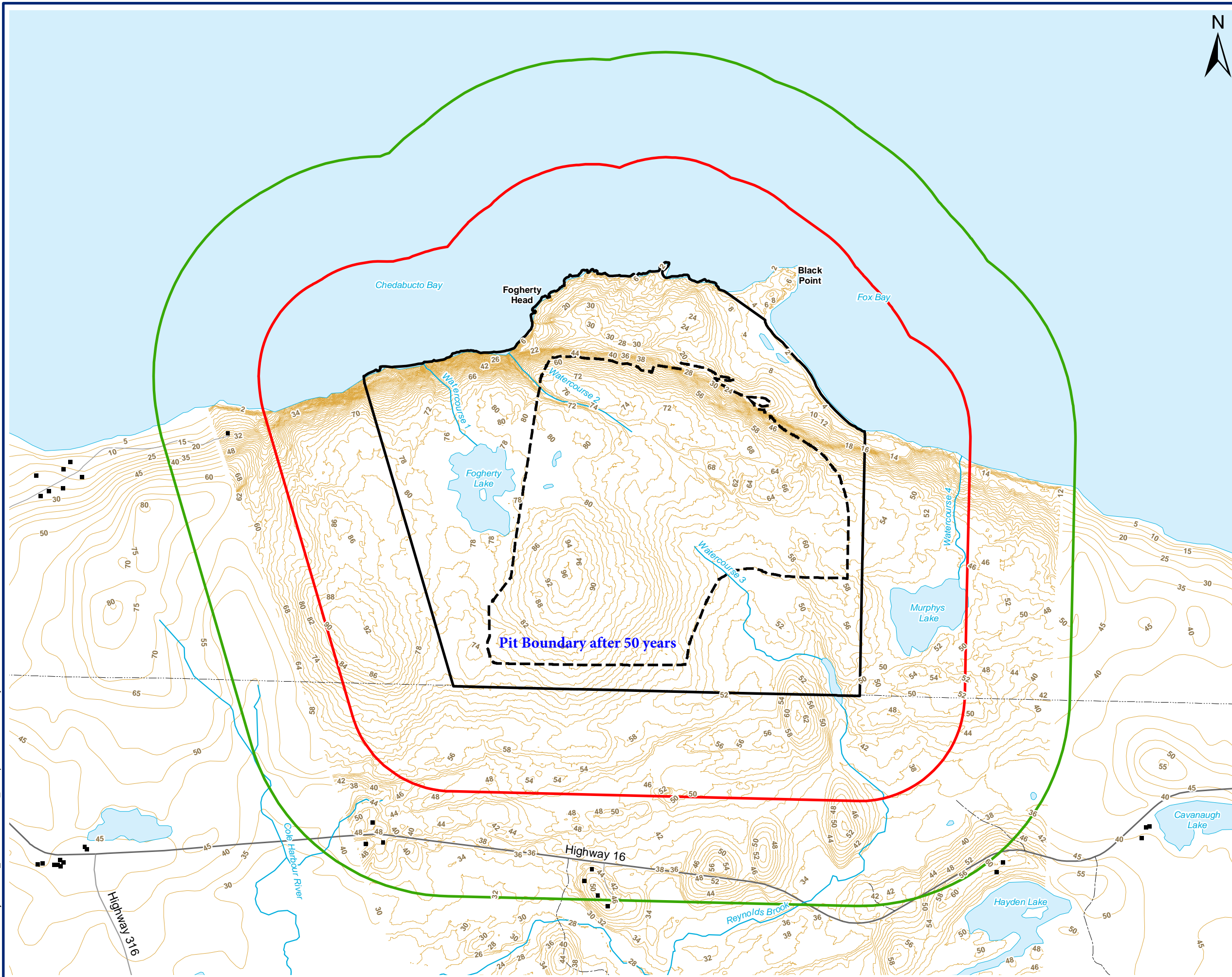

- LEGEND**
- Building
  - ▭ Property Boundary
  - ▭ Property Boundary (500 m Buffer)
  - ▭ Property Boundary (1000 m Buffer)
  - ▭ Waterbody
  - ▭ Watercourse
  - ▭ Elevation Contours (2m, derived from LiDAR, 5m from CANVEC)
  - ▭ Utility Line

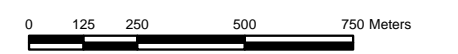

SCALE: 1:17,500  
WHEN PLOTTED CORRECTLY AT 11 x 17  
NAD 1983 UTM Zone 20N

**NOTES**  
This map is for conceptual purposes only and should not be used for navigational purposes.  
Basedata: Nova Scotia Natural Resources, downloaded, June 2014; Orthoimagery from GeoNOVA, 2007.

**MORIEN RESOURCES  
AND VULCAN MATERIALS**

BLACK POINT QUARRY

LOCATION OF NEAREST RESIDENCES

October 22, 2014	Rev <b>1.0</b>	Figure No.
Project No. 210.05913.00000		<b>1.0-4</b>



## 1.5 Ecological Overview

The 354.5 ha property measures approximately 2.75 km from east to west and is generally less than 2.0 km wide from north to south. Much of the terrain at higher elevations consists of exposed bedrock interspersed with thin, patchy vegetation and stunted trees. Vegetation and tree cover thicken at lower elevations on the flanks of the exposed granite dome. The massive granite rock limits infiltration of rainwater and snowmelt, resulting in a number of wetlands distributed across the property at lower elevations. In these areas (e.g., around Fogherty Lake) and extending north to the coast, wetlands mixed with mature black and red spruce forest dominate the landscape.

There are three unnamed watercourses on the site, including the outflow from Fogherty Lake, the only lake on the Black Point property (**Figure 1.0-4**). The watercourses are narrow, shallow and do not contain fish. One stream is ephemeral. Fogherty Lake is approximately 6.8 ha in surface area, but is relatively shallow and is strongly acidic. Water in the lake is dark brown and visibility is limited. Nearby Murphys Lake (6.0 ha in area) located east of the Black Point Property is also acidic and is ringed by wetlands.

A number of habitat types are encountered within the Project site. Most of the area is covered by a mosaic of barren vegetation, tall shrub barren, and some coniferous forest. There are also patches of mixed forest, and wetlands such as treed bog, open bog, fen, and swamp scattered throughout the Project site. A variety of other habitat types are also present, including beaches, coastal barren headlands, coastal cliffs, regenerating forests, and lakes.

NSDNR's Restricted and Limited Land Use map shows the following features in proximity to the proposed Project (**Figure 1.0-1**).

- Three private beaches protected under the Beaches Protection Act
  - Lower Half Island Cove 1.5 km west
  - Half Island Cove 2.7 km west
  - Fox Island Main 2.55 km east
- Two Wilderness Areas
  - the Bonnet Lake Barrens Wilderness Area (6.9 km southwest)
  - the Canso Coastal Barrens Wilderness Area (1.7 km south and east);
- A Designated Water Supply Area
  - Walsh or Wilkins Lake 4.5 km south and east;
- A Natural Watershed Municipal Surface Water Supply
  - Located 3.65 km south and east; and,
- Third Lake Operational Non-Designated Parks and Reserve
  - Located 4.2 km south and west.

## 1.6 Participants in the Environmental Assessment

### 1.6.1 Proponent

**Table 1.3:  
Project Proponent Contact Information**

Project:	Black Point Quarry Project
Proponent:	Black Point Aggregates Inc.
Postal Address:	1200 Urban Center Drive Birmingham, Alabama USA 35242
Contact Name:	Mr. Frank Lieth, Vice-President
Telephone: (Direct)	770-454-3626
Telephone: (Mobile)	404-293-1933
Fax:	205-298-2927
Email:	liethf@vmcmail.com

### 1.6.2 Corporate Information

As noted, the Proponent Black Point Aggregates Inc. is a wholly owned subsidiary of Vulcan Materials Company (Vulcan). Vulcan is a publically traded company with stock listing on the New York Stock Exchange under the symbol VMC. The corporate office for Vulcan is located in Birmingham, Alabama. Company governance is overseen by the Company's Board of Directors, which is majority controlled by non-Vulcan affiliated directors.

The President and Chief Executive Officer is Mr. J. Thomas Hill, who also serves on the Board of Directors. The company has a talented and experienced management team that oversees the company's 340+ facilities located in 20 states, Mexico and the Bahamas. Vulcan employs a local management model that organizes the operations into geography- and market-based regions. Each region has a management team responsible for providing direction and management oversight to the operations.

Vulcan has extensive corporate policies and procedures that apply to the company's operations and employees. These policies and procedures ensure consistency across the company with respect to the expectations, responsibilities and operation of various functional areas (e.g., accounting and finance, legal, human resources, etc.). The Safety, Health and Environmental Policy (SHE Policy) specifically addresses the company's commitment and direction regarding SHE issues. The SHE Policy is described in Section 1.6.3.

The Black Point Project will be subject to the same liability protection measures that are provided for other Vulcan operations. The primary liability protection measures are described below:

- Liability protection begins with minimizing the risk of an incident that could create liability. Risk is minimized by incorporating best management and proactive oversight procedures in the design, construction and operation of a project; such measures include:
  - Incorporation of safety protection measures in facility design such as equipment guarding, safe means of access to equipment, benching in quarry pit, etc; and implementation of Vulcan's safety management system to ensure that safe work procedures are followed to minimize the risk of employee injury during equipment maintenance and other work activities;
  - Implementation of Vulcan's Occupational Health and Safety Program that ensures that the employees are protected from work place exposures that could impact their health. The two areas of primary focus in a quarry setting are the control of worker exposure to noise and dust. The employee noise exposure limit applicable to the Black Point operation is 85 dB(A) for an 8-hour work shift. The work place employee exposure limit for crystalline silica exposures is 25 ug/m<sup>3</sup> for an 8 hours work shift.
  - Implementation of environmental control measures including dust control systems, containment systems for fuel storage tanks, water treatment systems, site drainage control and implementation of storm water management controls, and other measures that reduce the risk of environmental incidents that could create liability.
  - Training and supervision to ensure employees know how to do their jobs safely, and that they have the knowledge and experience to recognize and react to risks before an incident occurs. Vulcan will provide extensive training to all Black Point employees.
  - Work place and equipment inspections to identify conditions that could result in an incident so these conditions can be modified before an incident occurs. The Black Point Project site will be routinely inspected by plant employees and supervisors to ensure that issues are identified and addressed.
- The Black Point operation will maintain an Emergency Response and Spill Contingency Plan that the employees will be trained to implement in the event of an incident. The plan will outline the steps to be taken, responsibilities of key personnel, notification procedures for alerting emergency response agencies and regulatory agencies, and other measures to be implemented in the case of an emergency or major incident. The Black Point operation will coordinate with local response agencies on response procedures. Supplementary to this Plan, any additional response documents and plans specified by Canadian or Provincial regulations will be prepared and maintained as required.
- The Corporate Risk Management department at Vulcan's head office in Birmingham, Alabama is responsible for management of liabilities associated with the various business units, including any liabilities that arise due to the Black Point operation. Vulcan is self-insured for losses related to workers' compensation up to \$2,000,000 (US) per occurrence and automotive and general/product liability up to \$3,000,000 (US) per occurrence. Vulcan has excess coverage on a per occurrence basis beyond these retention levels. Additionally,

Vulcan maintains insurance coverage for excess liabilities that could arise and that are beyond the level that Vulcan desires to cover through the self-insurance process.

### **1.6.3 Safety Health and Environmental Policy**

As approved by the Board, Vulcan's SHE policy applies companywide, including all subsidiaries. It affirms that Vulcan will be a responsible steward with respect to the safety, health and environmental impact of the company's operations and products. Accordingly, Vulcan will:

- Strive to produce products safely and make concern for public health and the protection of the environment integral parts of Vulcan's operations.
- Endeavor to provide employees with a safe and healthy working environment.
- Reduce waste, conserve energy and recycle materials, to the extent practicable, and dispose of, or treat, waste responsibly.
- Provide education, training and leadership to employees to enable and motivate them to understand and comply with applicable law and these policies.
- Conduct reviews of safety, health and environmental practice at Vulcan facilities to verify compliance with applicable laws and regulations and to identify and correct operational practices that might impair safety, health or environmental quality at such facilities or in the neighborhoods in which we operate.
- Promote responsible stewardship of the company's products with carriers, distributors and customers.
- Promote the adoption of, and adherence to, sound safety, health and environmental practices by on-site contractors and tenants, directing where appropriate that contractors and tenants take corrective actions.
- Advocate the development of reasonable, scientifically sound and cost-effective safety, health and environmental laws and regulations that are based on realistic assessments of risk.
- Support and encourage the development of sound safety, health and environmental standards and practices in the industries in which Vulcan participates.

Vulcan is recognized as a leader in the Safety, Health and Environmental areas and maintains this leadership with a focus on continuous improvement.

As an operating facility within Vulcan Materials, the Black Point operation will be subject to Vulcan's internal policies and procedures as well as all applicable provincial and national regulations and requirements. Vulcan will ensure that the operation maintains compliance with internal and external requirements and expectations by providing training and direction to the site management team and employees, communicating expectations, and then checking through audits and inspections that all requirements and obligations are met. Vulcan understands the importance of providing a safe workplace, protecting our employees from work

place health hazards, being responsible members of the community and good neighbors, and of protecting the environment.

The company has an internal audit department that performs independent audits of the company operations, business units, and personnel for compliance with company policy and procedure. In addition, in the Safety, Health and Environmental (SHE) Audit Policy mandates periodic audits of each operation and of the operating regions.

#### **1.6.4 Environmental Consultants**

**Table 1.4:  
Environmental Consultant Contact Information**

Name	SLR Consulting (Canada) Ltd.
Postal Address	115 Joseph Zatzman Drive Dartmouth, NS B3B 1N3
Contact Name	Russell Dmytriw, M.Sc., P.Geo
Telephone	902-499-1190
Fax	902-420-9703
Email	rdmytriw@slrconsulting.com



Table 1.5 lists the key personnel responsible for completing the background studies and the EIS report

**Table 1.5:  
 Names and Qualifications of the Report Authors**

Name	Qualifications	Affiliation	Role
Russell Dmytriw	M.Sc., P.Geo.	SLR Consulting	EIS Project Manager
Steven Usher	P. Eng., P.Geo	SLR Consulting	Hydrogeology
Gordon Wichert	Ph.D, Biologist	SLR Consulting	Aquatic Biology
Paul Klimczak	M.Sc., Hydrologist	SLR Consulting	Hydrology
Briony Croft	Ph.D., MIEAust., CPEng.	SLR Consulting	Noise and Vibrations
Gillian Hatcher	M.A.Sc.	Stantec	Air Quality
Maureen Cameron-MacMillan	M.Sc. Biologist	AMEC	Bird Surveys/Ecology
Scott Burley	M.Sc. Biologist	AMEC	Wetlands/Terrestrial Habitats
Chris Milley	Senior Environmental Consultant	AMEC	First Nations

### **1.6.5 Aboriginal Groups**

A review of outstanding specific land claims was undertaken during the preparation of the Mi'kmaq Ecological Knowledge Study for the Black Point Quarry Project (Mi'kma'ki All Points Services 2013). At the time there were no specific land claims pending within the Project area. This does preclude future land claims in the area.

The nearest mainland First Nation (Mi'kmaq) community is Paqtnkek First Nation located in Afton, NS. Paqtnkek First Nation is 66 km north of Queensport in Antigonish County, mid-way between the Canso Causeway and the Town of Antigonish.

In addition to Paqtnkek, some members from the Millbrook and Sipekne'katik First Nations have been involved in the resource harvesting in the lands and waters near the Project area, and as a result are familiar with the region. Two other Mi'kmaq communities, Pictou Landing and Potoitek, are also in relatively close proximity to the Project Site (i.e., <150 km away).

The Assembly of Nova Scotia Mi'kmaq Chiefs is a key Aboriginal group, which has also participated in the environmental assessment process.

### **1.6.6 *Community and Environmental Organisations***

A number of community and environmental groups have expressed an interest in the Project, either through direct contact with the Proponent or through submissions made to the CEA Agency and NSE during the course of the environmental assessment. The Proponent's outreach efforts to these and other groups are described in Section 11. Table 1.6 lists the community and environmental organisations associated with the Project.

**Table 1.6:  
Environmental and Community Organisations**

Organization	
1	Chedabucto Education Centre/Guysborough Academy
2	Guysborough Memorial Hospital Foundation
3	Chedabucto Lifestyle Center
4	Guysborough County Adult Learning Association
5	Guysborough County Food Bank
6	Canso Lions Club
7	With A Little Help Society (W.A.L.H.S.)
8	Queensport Volunteer Fire Department
9	Out of the Fog Lighthouse Museum
10	Guysborough Amateur Athletic Association
11	Canso Library
12	Cyril Ward Memorial Library
13	Guysborough Waterfront Association
14	Ecology Action Centre
15	Guysborough County Inshore Fishermen's Association
16	Sierra Club Atlantic
17	Strait Area Chamber of Commerce
18	Mining Association of Nova Scotia

## 1.7 Project Schedule

Table 1.7 provides a generalized schedule that presents the major construction and operational milestones.

**Table 1.7:  
 Generalized Project Schedule**

Year	Activity Undertaken or Anticipated
2010-11	Baseline ecological studies initiated
	Initial engagement with the public, regulatory agencies and Mi'kmaq
2012-2013	Properties assembled by the MODG (beginning in 2007-2008)
	Environmental Assessment Initiated
2014	<ul style="list-style-type: none"> <li>• Consultation and engagement undertaken:</li> <li>• Meetings and site visits with Mi'kmaq representatives</li> <li>• Consultation and site visits with Regulatory Agencies</li> <li>• Meetings with residents and local fishermen</li> <li>• Open Houses, presentations, and meetings of the Citizen's Liaison Committee (CLC)</li> <li>• Submission of the draft EIS for review by the CEA Agency and NSE</li> </ul>
2015	Submission of the Environmental Impact Statement report Completion of the environmental assessment
2016	Permits and Approvals
Early 2017	Updated Market Evaluation
2017-2018	Establishment of Sales Yards Receipt of Aggregate by Vessel from Black Point
2018-2021	Construction and Equipment Testing (Limited Production)
2021	Commence Full Scale Operations
2070+	Closure and Decommissioning

## 1.8 Purpose of the Project

The purpose of the Black Point Quarry Project is to supply construction aggregate to markets predominantly on the eastern and Gulf coasts of the United States and possibly to markets in eastern and central Canada. Construction aggregates are composed primarily of crushed stone (the product from Black Point), natural sand and gravel. These resources are needed for the development and maintenance of modern infrastructure. Although construction aggregates have numerous end uses, their general application is in the production of building materials such as concrete and asphalt. In general concrete is about 80% aggregate and asphalt is about 94% aggregate.

While natural materials used to produce construction aggregates (stone, sand and gravel primarily) are relatively abundant, these resources must be located in areas that are geographically accessible. In addition, the rights and permits to recover the resources must be obtainable, and there must be sufficient market capacity to support the planned production of the mining operation. Finally, aggregates must meet strict quality requirements related to the chemical and physical characteristics of the rock. Most rocks do not meet these geographic conditions and quality specifications and cannot qualify as viable construction aggregate resources.

In the U.S. market, the majority (80% or more) of aggregates are transported by truck from the quarry to the consumer. This form of transport is expensive and limits the typical aggregate operation to a market radius of about 80 km from the quarry. Coastal markets within the US are increasingly using high volume modes of transportation such as rail and ship to minimize costs. The south eastern U.S. aggregate market is a prime target for bulk vessel transported aggregate due in part to the geologic absence of suitable aggregate resources in coastal areas. For example, the Martin Marietta Materials quarry at Aulds Cove, NS shipped nearly 300 vessels of crushed stone to Florida ports between 2004 and 2009 (ACS 2009).

### **1.9 Benefits of the Project**

The benefits of the Black Point Quarry Project to Canadians and Nova Scotians are numerous. The revenue generated from the Project will provide economic benefit to the people and governments of Guysborough County and Nova Scotia through taxes paid, dollars invested into goods and services directly by the Project Proponent, and indirect dollars that will go into local businesses and services from employees and contractors working on the Project and at the quarry. Specifically, the investment will be in the US\$80-\$110MM range. The construction and site development phases of the Project will generate between 120-150 direct and indirect jobs. Once operational, there will be 50-60 full time jobs associated with the operations. Based on experience at other Vulcan quarries, the annual operating expenses are estimated to be in the range of US\$9-\$15MM which is spent on wages, fuel, electricity, operating parts and maintenance. Additionally, numerous local vendors, service providers and consultants would be engaged in activities at the quarry.

Additional benefits that the environmental assessment process has generated since the Project was proposed revolve around the increased levels of consultation the community, the Mi'kmaw, and local fishermen. The dialogue that has occurred to date has been driven by a genuine interest to harmoniously coexist with the Project's Guysborough County neighbours, but is also mandated in the assessment process and facilitated by open comment periods. Exchanges with these groups, numerous site visits, and presentations at schools and business forums have improved the quality of information presented in the EIS report and established a baseline example for future interactions over the life of the Project.

Examples of changes to the Project and critical information incorporated into the EIS through community dialogue include:

#### Fisheries

- Over the course of multiple consultation events, the Proponent's proposed vessel approach routes between the marine terminal and the main shipping lane in Chedabucto Bay were reviewed and critiqued by local area fishermen. This process resulted in the selection and

modification of a preferred route intended to avoid preferred fishing grounds to the extent possible<sup>1</sup>.

- Several potential fisheries offset project locations were identified during meetings with local fishermen. These include areas immediately west of the Project and well as in Indian Cove.
- Mackerel and shrimp migration patterns in the immediate area nearshore environment to the marine terminal are best understood by the fishermen. Mitigation measures will take that input into account.
- Lobster spawning concerns and considerations relative to blasting in the nearshore terrestrial environment were issues that the fisherman wanted more information about and assurances that no impact will occur. The Proponent provided the fisherman with academic studies related to blasting in the nearshore environment and utilized the same information to generate blasting setbacks as reported in this EIS report.

### The Mi'kmaw

- The constructive and open dialogue encouraged during meetings, presentations and site visits have generated a mutual awareness and understanding of the needs and intentions of the other, which will survive the duration of the environmental assessment process.
- The Mi'kmaw have been made aware of the anticipated benefits of the Project, the potential environmental impacts and proposed mitigation measures aimed at minimizing those impacts as well as the sustainable practices and environmental track record of the Proponent.
- The Proponent has learned a great deal with respect to Mi'kmaq history, culture, and land use rights in Nova Scotia. The Proponent has also been made aware of type and number of Mi'kmaq labor and vendor resources who desire training and employment, which the Project will need during construction and operation.

### Local Community

- Several meetings and presentations were used to describe mining processes and quarry-specific vocations to interested students to help prepare them for Project related employment opportunities.
- Meetings were also used to describe background environmental conditions including residential water quality results, wetland function and the results of biological surveys.

The baseline environmental testing and monitoring at the site add to the scientific understanding and background data held by the Province. This background information contributes to a knowledge base that ultimately helps to increase public ecological awareness and promote conservation.

---

<sup>1</sup> The local fishermen selected a preferred route (one of two presented) then requested further modifications to the preferred route, which were incorporated to establish a final route shown on Figure 3.0-29.

## 2.0 REGULATORY FRAMEWORK

### 2.1 Federal

The Black Point Quarry Project is proposed within a framework of federal and provincial laws and municipal by-laws. These laws describe the environmental assessment process, the permits required for operation and construction, and the conditions under which the Project will be operated. The Project is also subject to a number of guidelines, policies and standards that are applied during the design, construction and operation of the Project. Governing legislation is listed in **Table 2-1** while the key laws are described in more detail below.

#### 2.1.1 *Canadian Environmental Assessment Act (CEAA 2012)*

The *Canadian Environmental Assessment Act, 2012 (CEAA 2012)* regulates the federal government's environmental assessment process. Section 8 of *CEAA 2012* requires that the Proponent of a "designated project" provide the Canadian Environmental Assessment Agency (CEA Agency) with a Project Description so that the federal Minister of the Environment can determine whether an environmental assessment is required. Designated project types are listed in the *Regulations Designating Physical Activities*. The Black Point Quarry Project includes two activities (or project types) listed in the *Regulations* and is therefore subject to a federal environmental assessment:

**16(g)** the construction, operation, decommissioning and abandonment of a **new stone quarry** or sand or gravel pit with a production capacity of 3,500,000 tonnes per year or more;

**24(c)** the construction, operation, decommissioning and abandonment of a **new marine terminal** designed to handle ships larger than 25,000 DWT unless the terminal is located on lands that are routinely and have been historically used as a marine terminal or that are designated for such use in a land-use plan that has been the subject of public consultation.

The CEA Agency both leads and coordinates agency review of and response to the Proponent's EIS report.

#### 2.1.2 *Canadian Environmental Protection Act 1999*

The *Canadian Environmental Protection Act 1999 (CEPA 1999)* is aimed at the prevention and management of risks posed by toxic and other harmful substances. CEPA 1999 also manages environmental and human health impacts of marine pollution, disposal at sea, certain atmospheric emissions, hazardous wastes, environmental emergencies and other sources of pollution.

With respect to marine pollution, CEPA 1999 provides the authority to issue non-regulatory objectives, guidelines and codes of practice to prevent marine pollution from land-based sources. It also prohibits the disposal of wastes at sea within Canadian jurisdiction and by Canadian ships in international waters unless a permit is obtained. Dredging is not currently anticipated at the Black Point Project; should this change, a permit allowing disposal at sea of dredged materials would be required.

### **2.1.3 Fisheries Act**

The recently amended *Fisheries Act* protects the sustainability and productivity of recreational, commercial and Aboriginal fisheries. Among other things, the amendments re-emphasize the Proponent's responsibility to avoid harm to fish and fish habitat through the application of appropriate design and mitigation measures.

People are prohibited from harming fish in section 35(1) *No person shall carry on any work, undertaking or activity that results in serious harm to fish that are part of a commercial, recreational or Aboriginal fishery, or to fish that support such a fishery, except if the work or activity is authorized by or carried on in accordance with the regulations made under the Act.* This prohibition is supported by definitions of commercial, recreational and Aboriginal fisheries in the *Act*, as well as a definition of "serious harm to fish", which is the *death of fish or any permanent alteration to, or destruction of, fish habitat.*

In addition, Section 36(3) of the *Fisheries Act* prohibits discharge or deposit of "a deleterious substance in water frequented by fish" unless allowed by regulation.

In consequence of this regulation, DFO authorization may be required to construct the marine terminal. In contrast, no freshwater fishery is present due to the low pH of Fogherty Lake and the freshwater streams on the site, and so no DFO authorization is required for the terrestrial components of the Project.

### **2.1.4 Migratory Birds Convention Act, 1994**

The *Migratory Birds Convention Act* (MBCA) protects migratory bird species and states that no person shall disturb, destroy or take a nest, egg, nest shelter, eider duck shelter or duck box of a migratory bird without a permit. Section 5.1 of the *Migratory Birds Convention Act* prohibits the deposit of substances harmful to migratory birds:

"5.1 (1) No person or vessel shall deposit a substance that is harmful to migratory birds, or permit such a substance to be deposited, in waters or an area frequented by migratory birds or in a place from which the substance may enter such waters or such an area.

(2) No person or vessel shall deposit a substance or permit a substance to be deposited in any place if the substance, in combination with one or more substances, results in a substance — in waters or an area frequented by migratory birds or in a place from which it may enter such waters or such an area — that is harmful to migratory birds."

### **2.1.5 Species at Risk Act**

The *Species at Risk Act* (SARA) protects wildlife species from becoming extinct through prohibitions against killing, harming, harassing, capturing or taking species at risk, and against destroying their critical habitats. Management of species at risk and species of special concern (as identified by the Committee on the Status of Endangered Wildlife in Canada [COSEWIC]) is accomplished by providing for the recovery of species at risk and by ensuring through sound management that species of special concern do not become endangered or threatened. In the aquatic environment, DFO is responsible for freshwater and marine species at risk, while Environment Canada (EC) is responsible for all other species at risk.



### **2.1.6 Canada Shipping Act, 2001**

The *Canada Shipping Act, 2001* governs safety in marine transportation, recreational boating and the protection of the marine environment. It applies to Canadian vessels operating in all waters and to all vessels operating in Canadian waters. The *Vessel Pollution and Dangerous Chemicals Regulations* lists prohibited ship-source discharges including: oil, noxious liquid substances and dangerous chemicals, sewage, garbage and air anti-fouling systems. Regulations under the Act are also meant to prevent and respond to marine spills from vessels and require vessels to manage ballast water to reduce the potential for invasive (non-native) organisms (*Ballast Water Control and Management Regulations*).

### **2.1.7 Oceans Act**

The *Oceans Act* sets out Canada's role with respect to oceans management, specifying the need to integrate marine conservation with development activities to maintain healthy ecosystems. The *Act* is implemented through three programs: the Marine Protected Areas Program (a national system of marine protected areas, including designating areas for special protection), the Integrated Management Program (leading, facilitating and implementing plans for the integrated management of all activities or measures in or affecting estuaries, coastal and marine waters), and the Marine Ecosystem Health Program (establishing marine environmental quality guidelines).

### **2.1.8 Navigation Protection Act**

The Navigation Protection Act (NPA) protects the public's right to navigation and marine safety in Canadian waters. Administered by Transport Canada, the NPA requires approval for any works that may affect navigation on navigable waters in Canada. Given this, the construction of the marine terminal will require approval under Section 6(1) of the NPA.

In addition to these laws, the follow legislation also applies to the Black Point Quarry Project:

- The *Marine Transportation Security Act* provides regulatory measures for marine and port security.
- The *Pilotage Act* the General Pilotage Regulations and the Atlantic Pilotage Authority Regulations establish pilotage authority and requirements within areas where local ship pilots are required by law to assist the masters (captains) of incoming vessels. The Black Point marine terminal is situated within a Compulsory Pilotage Area administered by the Atlantic Pilotage Authority.

## **2.2 Provincial**

### **2.2.1 Environmental Assessment**

Provincial environmental assessments are regulated under Nova Scotia's *Environment Act* and *Environmental Assessment Regulations*. Projects subject to environmental assessment are divided into two classes, Class I and Class II. As a quarry larger than 4 ha and an undertaking that may disrupt wetlands in excess of 2 ha, the proposed Project is considered to be a Class 1 Undertaking, which requires the submission of an Environmental Assessment Registration Document. Further requirements for the provincial environmental assessment process have

been established in the Guide to Preparing an EA Registration Document for Pit and Quarry Developments in Nova Scotia (NSE 2009a).

Many of the provincial permits required for this Project, including the primary operating permit - the Industrial Approval - originate from stipulations in the provincial *Activities Designation Regulations* made under Section 66 of the *Environment Act*. The *Activities Designation Regulations* provide permitting guidance to watercourse alterations and wetland alterations, groundwater surface water withdrawal, and construction of infrastructure in the marine environment.

The application for Industrial Approval, like other permit applications, is made once environmental assessment approval has been received. The Industrial Approval defines specific operational conditions and limitations, including dust, noise, surface water and groundwater discharge criteria and follow-up monitoring plans.

### **2.2.2 Harmonization**

*CEAA 2012* also allows the federal Minister of Environment to enter into agreements with provincial and territorial governments relating to the environmental assessments of projects where both federal and provincial governments have an interest. For this project, the CEA Agency and NSE have determined a harmonized federal/provincial environmental assessment process is achievable. A Federal-Provincial Environmental Assessment Agreement has been established to define the roles and responsibilities of the different departments, establish a timeline for the review process, and ensure the federal and provincial requirements are coordinated. This Agreement stipulates that a single environmental assessment report will address the interests of both federal and provincial government departments and agencies.

### **2.2.3 Resource Management Initiatives**

There are a number of government initiatives and resource management policies that have implications to the Black Point Project design and operation. Most important are those wildlife conservation and management policies applicable to Species at Risk. In addition, a number of commercial fishery resource management initiatives have been implemented by DFO and the Guysborough County Inshore Fisheries Association (GCIFA).

Once a species is listed under the provincial *Endangered Species Act*, a Recovery Plan is developed for those species designated Endangered and Threatened and a Management Plan is developed for Vulnerable designated species.

The Mainland Moose Recovery Plan is once such policy (NSDNR 2007a). Nova Scotia's Mainland Moose population was first listed as provincially endangered in 2003. The Recovery Plan defines the recovery goal, objectives, strategies, and actions that have been developed to protect, conserve, and recover this species in Nova Scotia. The objectives of the Plan are to: 1) maintain and enhance the current population and distribution; 2) mitigate threats that limit recovery; 3) initiate research to address knowledge gaps; and 4) maintain and enhance habitat. The Plan indicates that these objectives will be achieved through research, monitoring, management, education and stewardship. Since Mainland Moose have been identified on the Black Point Quarry property and the Project is expected to impact this species, the Proponent has integrated the objectives and recovery approaches within the design and long term monitoring objectives of the Project (Section 7.12).

Funding for research aimed at understanding conservation options for three recently listed bat species has also been allocated by the province (not related to the Black Point Project), although a specific recovery plan has not been developed for these species. Bat populations have suffered severely from a fungal infection termed white-nose syndrome, which has led to catastrophic population declines in eastern North America.

DFO has developed Integrated Fisheries Management Plans (IFMPs) to manage and guide the sustainable management of commercial fisheries resources (DFO 2014a). Among other things the plans establish fishing seasons and fishing quotas. Within the Maritimes Region (where the Project is situated) IFMPs are in place for:

- Lobster
- Herring
- Atlantic Seal (various species)
- Atlantic Mackerel
- Bluefin Tuna
- Atlantic Swordfish and Other Tunas
- Canadian Atlantic Herring
- Canadian Atlantic Swordfish and Other Tunas
- Shrimp – Scotian Shelf

The use of these IFMPs to guide commercial fisheries in Chedabucto Bay is described in Section 6.10.

The *National Framework for Canada's Network of Marine Protected Areas* seeks to establish a network of marine protected areas (MPAs) in Canadian waters. The overarching objective of the *Framework* is to provide long-term protection of marine biodiversity, ecosystem function and special natural features. To achieve this objective, the *Framework* provides guidance for Canadian MPA network planning and design and states that MPA networks should identify Ecologically or Biologically Significant Areas (EBSAs). To this end, the Canso Ledges EBSA, which includes the Project site, was identified in 2012 (DFO 2012a).

#### **2.2.4 Permits and Authorizations**

In addition to the above-described environmental assessment requirements, the Project will also require a number of federal and provincial regulatory permits and approvals prior to proceeding. These permits are typically issued after the successful completion of the environmental assessment. The key environmental permits anticipated are listed in **Table 2.1**.

**Table 2.1:  
Anticipated Key Permitting Requirements**

<b>Regulatory Requirement</b>	<b>Approval/Permit</b>	<b>Sections</b>	<b>Project Activity/Trigger</b>	<b>Responsible Agency</b>
<b>FEDERAL</b>				
CEAA 2012	Assessment	S. 16(g), 24(c)	Construction of a stone quarry of greater than 2.5 MT capacity; construction of a marine terminal hosting vessels larger than 25000DWT	CEA Agency
Fisheries Act and Regulations	Authorization	S. 35(1)	Marine terminal construction; prohibits deposit of a deleterious substance in waters frequented by fish	Fisheries and Oceans Canada
Navigation Protection Act	NPA Approval	S. 6 (1)	Marine terminal construction, installation of watercourse crossings	Transport Canada
Transportation of Dangerous Goods Act	NA	NA	The movement of dangerous good to, from and within the site must comply with applicable regulations under the Act	Transport Canada
Migratory Birds Convention Act	NA	S. 5 and 5.1	The Proponent will comply with the Migratory Birds Convention Act and associated regulations, including prohibitions against harming migratory birds to depositing substances which may harm these birds	Environment Canada
Canada Shipping Act (Ballast Water Control and Management Regulations)	NA	NA	Code of practice for shipping operations	Transport Canada
National Building Code of Canada	Approval	NA	Building occupation	MODG
<b>PROVINCIAL</b>				
Environmental Assessment Regulation under the NS Environment Act	Approval/Release	32	Prohibits work on an undertaking without an approval	Nova Scotia Environment
Activities Designation Regulations under the NS Environment Act	Water Approval	S. 5(1) various	Water withdrawal, alteration of water bodies and/or wetlands associated with quarry development	Nova Scotia Environment
Activities Designation Regulations NS Environment Act	Part V Industrial Approval	S. 13(f)	Quarry development and operation	Nova Scotia Environment
Activities Designation Regulations under the NS Environment Act	Permits	various	Wharf construction, chemical storage tank in excess of 2000L, wastewater treatment system	Nova Scotia Environment

Regulatory Requirement	Approval/Permit	Sections	Project Activity/Trigger	Responsible Agency
			construction, etc.	
Petroleum Management Regulation	Registration	S. 11(1)	Underground and aboveground petroleum storage tanks of 2000L or greater	Nova Scotia Environment
Air Quality Regulation	NA	Schedule A	Establishes ambient air quality criteria	Nova Scotia Environment
Dangerous Goods Management Regulation	Approval	S. 6(1)	Requires written approval to store dangerous waste goods	NSDNR
Beaches Act and Beaches Regulations	Permit	S. 7	Authorizes construction activities below the ordinary high water mark	NSDNR
Special Places Protection Act and Regulations	Permit	S. 8(1)	Authorizes an Archaeological Resources Impact Assessment	NS Department of Communities, Culture and Heritage
Nova Scotia Wildlife Act and Regulations	Permit	50(1)	Prohibits the taking, hunting or killing or possession of eagles, osprey, falcons, hawks, owls or any protected wildlife	NSDNR
Nova Scotia Endangered Species Act	Permit	S. 14	Prohibits harm to or interference with an endangered or threatened species and their habitat. The permit authorizes activities that would otherwise be prohibited	NSDNR
Crown Lands Act and Regulations	Crown Land Lease for Submerged Lands		Governs the use of lands owned by the Province. A Lease is required for use of the seabed to construct the marine terminal	NSDNR

As the Project is currently planned, no explosives will be stored or manufactured on site and no dredging will be required.

### 2.3 Municipal

The Municipality of the District of Guysborough employs a Land Use By-Law to manage development within the municipality. Aggregate quarries are permitted in lands zoned Industrial Heavy (I-2) but these projects must obtain a development permit prior to construction. Applications must be accompanied by site plans showing lot dimensions, structures and buildings, location of watercourses, and other information. Building permits will also be required prior to construction.

### 2.4 Policies and Guidelines

There are a number of federal and provincial policies, guidelines, standards and codes of practice that will apply to the construction and operation of the Black Point Project. Table 2.2 lists these documents.

**Table 2.2:**  
**Federal and Provincial Policies and Guidelines**

**Federal**

1. Canadian Council of Ministers of the Environment (CCME) Canadian Environmental Quality Guidelines (CCME 1999a).
2. CCME Canadian Environmental Quality Guidelines, Water: Aquatic Life (Freshwater and Marine) (CCME 1999b).
3. CCME Canadian Environmental Quality Guidelines, Sediment Quality Guidelines (SQGs) for Protection of Aquatic Life (CCME 2001).
4. CCME Canadian Environmental Quality Guidelines, Soil: Commercial/Industrial Sites (CCME 1999c).
5. CCME Canada-Wide Standards for Particulate Matter (PM) and Ozone (CCME 2010)
6. National Fire Code of Canada.
7. Useful Information for Environmental Assessments (Health Canada 2010).
8. Guidelines to Avoid Disturbance to Seabird and Waterbird Colonies in Canada (EC 2013a).
9. Guidelines for the Use of Explosives In or Near Canadian Fisheries Waters (DFO 1998).
10. Operational Policy Statement Assessing Cumulative Environmental Effects Under The Canadian Environmental Assessment Act (CEA Agency 2013a).
11. Canadian Environmental Protection Act (EC 1999).
12. Changes to the Fisheries Act (DFO 2013b).
13. Atlantic Canada Wastewater Guidelines Manual for Collection, Treatment and Disposal (EC 2006).
14. Guide for Reporting to the National Pollutant Release Inventory (NPRI) 2012/2013 (EC 2013b).
15. Applications For Authorization under Paragraph 35 (2)(b) of the Fisheries Act Regulations (Government of Canada 2013a).
16. Fisheries Productivity Investment Policy: A Proponent's Guide to Offsetting (DFO 2013c).
17. Fisheries Protection Policy Statement (DFO 2013a).
18. National Guidelines for Monitoring Dredged and Excavated Material at Ocean Disposal Sites (EC 1998).
19. Aboriginal Consultation and Accommodation: Updated Guidelines for Federal Officials to Fulfil the Duty to Consult (GC 2013b).
20. Addressing "Purpose of" and "Alternative Means" under the Canadian Environmental Assessment Act, 2012 (CEAA Agency 2013b).
21. Federal Policy on Wetland Conservation (GC 1991)

**Provincial**

1. Guideline for Environmental Noise Measurement and Assessment (NSEL 1990).
2. Guidelines for the Management of Contaminated Sites in Nova Scotia (NSEL 1996).
3. Nova Scotia Climate Change Action Plan (NSE Guidelines) (NSE 2009c).
4. Guide to Considering Climate Change in Environmental Assessment (NSE 2011a).
5. Guide to Consider Climate Change in Project Development in NS (NSE 2011b).
6. Guide to Addressing Wildlife Species and Habitat in an EA registration document (NSE 2009a).
7. Nova Scotia Wetland Conservation Policy (NSE 2011c).
8. From Strategy to Action, An Action Plan for the Path We Share, A Natural Resources Strategy for NS (NSDNR 2011a).
9. The Path We Share: A Natural Resources Strategy for NS 2011-2020 (NSDNR 2011b).
10. Water for Life: Nova Scotia's Water Resource Management Strategy (NSE 2010).

11. Nova Scotia Standard Specifications. Highway Construction and Maintenance (NSTPW 1997).
12. Sediment and Erosion Control Handbook (NSE 1988).
13. Watercourse Alteration Protection; Erosion Protection; Wharves; Pipe Culverts; Arch or Open Bottom Box Culverts (NSE 2013).
14. Generic Environmental Protection Plan for Construction of 100 Series Highways (NSTPW 2007).
15. Guide to Preparing an EA Registration Document for Pit and Quarry Developments in Nova Scotia. (NSE 2009b).
16. A Proponents Guide to Environmental Assessment. Nova Scotia Department of Environment (NSE) 2001.
17. Nova Scotia Standards for Construction and Installation for Petroleum Storage Tank Systems (NSEL 1997).
18. Guidelines for Monitoring Public Drinking Water Supplies (NSEL 2005).
19. Storm Drainage Works Approval Policy (NSEL 2002).
20. Pit and Quarry Guidelines (NSEL 1999).
21. Proponent's Guide: Engagement with the Mi'kmaq of Nova Scotia (Government of Nova Scotia 2009).
22. Guidelines for the Development on Slates in Nova Scotia (NSE 1991).

## **2.5 First Nations**

As noted in Section 1.6.5 a review of outstanding specific claims was undertaken during the preparation of the Mi'kmaq Ecological Knowledge Study undertaken for this project. At the time there were no specific claims pending within the Project area. This does preclude future land claims in the area. To the best of the Proponent's knowledge, there are no treaty or self-government agreements with the Mi'kmaq that are pertinent to the project and/or the environmental assessment.

### 3.0 PROJECT DESCRIPTION

#### 3.1 OVERVIEW OF PROJECT COMPONENTS AND SITE LAYOUT

The Black Point Quarry Project consists of aggregate production (drilling, blasting, processing, and stockpiling), along with the construction and operation of a marine terminal in Chedabucto Bay adjacent to the quarry.

The anticipated average annual production rate will exceed 1.0 million metric tonnes (MT) with an anticipated peak annual production of 7.5 MT depending on prevailing market conditions. Estimated rock reserves in the proposed quarry area are upwards of 400 MT. Quarry operations are expected to take place over an approximate 50+ year period, depending on the demand for aggregate and annual production volumes.

The anticipated processing plant schedule will be 24 hr/day with two 8-hr operating shifts plus one 8 hour maintenance shift, 7 days/week. The plant will operate for nine months of the year weather permitting. The quarry will also operate for nine months of the year. When a ship is present, the marine operations will run 24 hr/day, up to 7 days per week, anytime during the year to accommodate shipping schedules and the time needed to load ships.

The primary components associated with the Project include:

- An unpaved access road from provincial Route 16 into the quarry;
- The quarry and primary crushing area;
- Main feed conveyer from the primary crusher to the processing plant;
- The processing (finishing) plant consisting of secondary and tertiary processing (crushing and washing) and a stockpile laydown area;
- Modular buildings that comprise the administration complex; and,
- A 160 m long marine terminal and load-out facility.

The locations of the primary project components are depicted in **Figure 3.0-1**.





Marine Terminal

Plant Area

Administrative Area

Transmission Line

Main Feed Conveyor

Primary Crushing Area

Quarry Area

Ultimate Pit Boundary

Access Road

Property Boundary

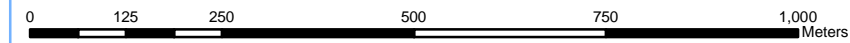

PLOTTED: LAST UPDATE:



DATE	REVISION	BY	ISSUE DATE:

THIS DRAWING IN DESIGN AND DETAIL IS THE PROPERTY OF VULCAN MATERIALS COMPANY AND MUST BE RETURNED UPON DEMAND. THIS DRAWING MUST NOT BE COPIED, REPRODUCED, OR USED WITHOUT PERMISSION.



Site Components

REGION	NOVA SCOTIA	PLANT	BLACK POINT
OWN BY	CKR	DATE	01/16/2015
CHECK BY		SCALE	1 in = 250 m
JOB NO.			

DWG. NO. Figure 3.0-1



### **3.1.1 Access Road**

A single private access road to the quarry site, processing plant, and marine terminal will be constructed prior to mining. Vehicular access will be primarily by construction workers during the construction phase and by employees and delivery/service vehicles once the site is operational. The access road will be a 10 m wide unpaved road north from Route 16 along the centerline of easement EA-1 to the southern property boundary, a distance of approximately 800 m (**Figure 3.0-1**). From the southern property boundary, the road will be extended easterly and northerly approximately 2.5 km to access the processing area and marine terminal. The access road will remain inside a 30 m wide buffer around the periphery of the property and, to the extent possible, will be constructed a minimum of 30 m from wetlands.

The access road will be designed to accommodate the anticipated load and size of Project-related vehicles. The intersection of Route 16 and the access road will be designed to meet Nova Scotia Department of Transportation and Infrastructure Renewal (NSTIR) standards. Where possible fill materials required for access road construction will be obtained from within the property. No bridges will be required. Culverts will be installed across any watercourses along the access road in accordance with NSE standards and permit requirements. At this time, only one culvert appears to be needed.

### **3.1.2 Open Pit Quarry**

The site will be developed as an open pit quarry using conventional surface mining methods. The mining cycle will include the following basic actions:

- Loosening and stockpiling of the vegetation, overburden, and loose rock by dozer and/or track hoe equipment;
- Drilling and blasting to establish benches, haul roads, and sumps for stormwater management;
- Loading of loosened rock into haul trucks by track-mounted and/or rubber tired loading equipment; and
- Transportation of the quarried rock by haul trucks to a discharge point at the edge of the quarry for feed to the primary crusher.

**Figures 3.0-2 through 3.0-12** show the development of the quarry over time, and list the milestones for each project phase. In general, mining will commence on the north end of the property beginning at the top of the granite hill near the northeast corner of the site. The quarry will be developed initially in a westerly direction before proceeding in a southerly direction to a final grade at or near elevation -30 m asl (i.e., 30 m below sea level). The final quarry footprint will comprise approximately 180 ha.

Overburden will be removed only as necessary to facilitate access to granite reserves. All overburden will be stored on-site for use in the reclamation process or partially used for construction of on-site berms, impoundments and haul roads. The storage locations include the screening berm along the southern portion of the access road and within the open pit. Once the

vegetation and overburden have been removed, drilling and blasting will be used to mine material and establish benches along the rock face.

Holes will be drilled into the rock to receive the explosives used for blasting. In general, the rock will be blasted along specific drill patterns that will maximize rock breakage and minimize wasted energy. It is anticipated that blasting will occur 30 days per year during the initial project phases, and increase to a maximum of about 200 days per year at full operation. All blasting activities will be conducted by a licensed contractor. Blasting will not be undertaken on Sundays or statutory holidays.

Freshly mined rock will be transported to and reduced in size by a primary crusher located on a bench on the east side of the quarry (see **Figure 3.0-1** for location). The crushed material will then be transported via conveyor to the processing plant (see Section 3.1.3 for a detailed description of processing).

As quarry development progresses, essential milestones will be established to ensure sufficient access to reserves to meet production requirements. The preliminary milestones include:

- Access road and plant pad development;
- Establish haul ramp from plant pad to an elevation of 52 m asl (primary dump elevation);
- Locate primary crushing station;
- Construction of up to a 16.9 million gallon (64,000 m<sup>3</sup>) temporary sump;
- Establish haul ramp down to an elevation of 22 m asl to prepare for construction of main pit sump; and
- Construction of up to a 102 million gallon (386,000 m<sup>3</sup>) permanent sump.

During the initial phases, the materials mined will be utilized during the plant development and construction.



# Pre-Mining : Plant Pad and Entrance Road Construction

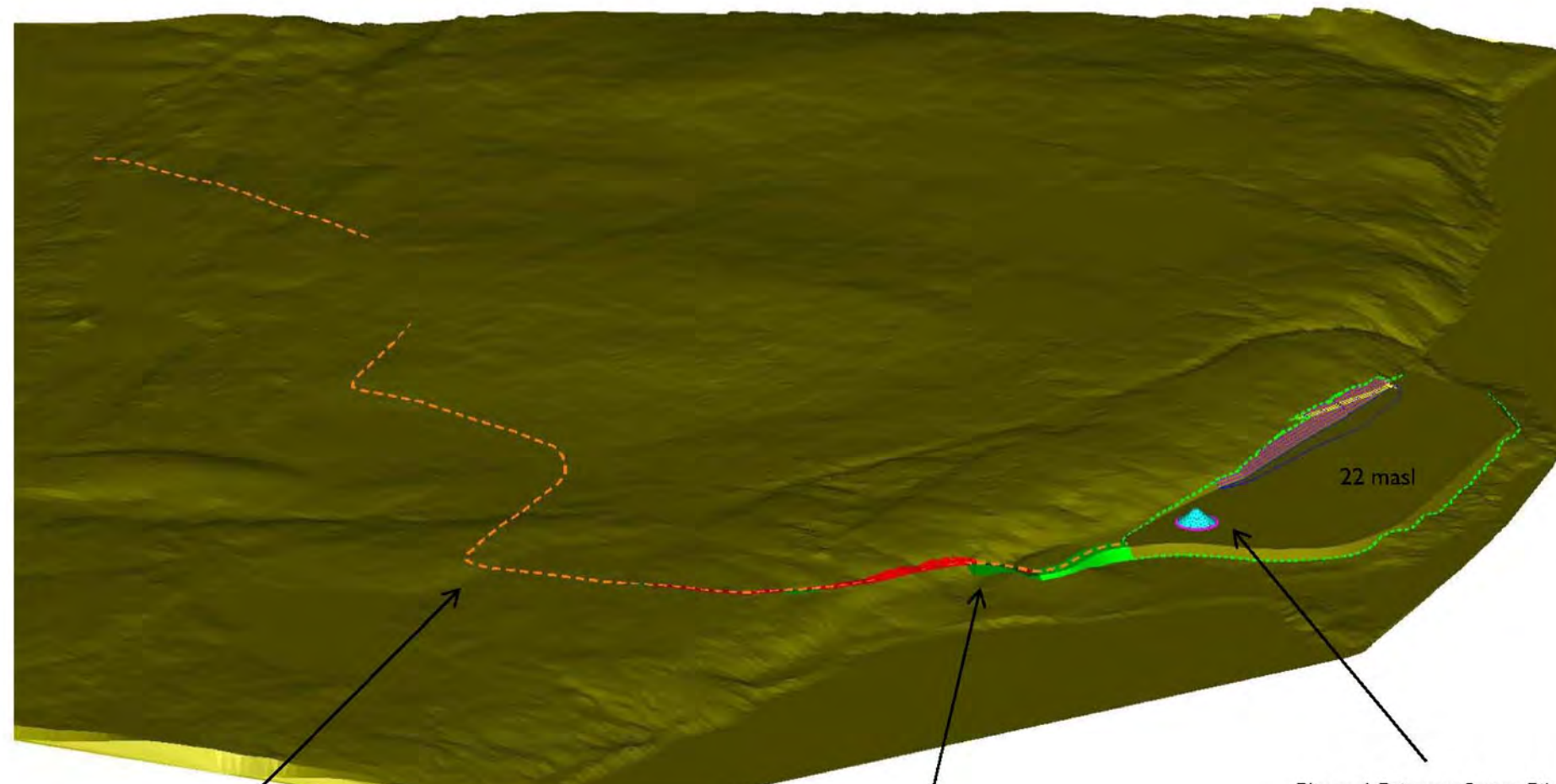

Entrance Road center Line  
( Orange dotted line )

Cut ( Red ) and Fill ( Green )  
For entrance road construction

Phase 4 Primary Surge Pile  
Just for Reference

PLOTTED: LAST UPDATE:



DATE	REVISION	BY	ISSUE DATE:

THIS DRAWING IN DESIGN AND DETAILS IS THE PROPERTY OF VULCAN MATERIALS COMPANY AND MUST BE RETURNED UPON DEMAND. THIS DRAWING MUST NOT BE COPIED, REPRODUCED, OR USED WITHOUT PERMISSION.



Pre-Mining	

REGION	NOVA SCOTIA	PLANT	BLACK POINT				
DRAWN BY	BH	DATE	10/22/2014	CHK BY		DWG. NO.	
JOB NO.		SCALE	No Scale				

Figure 3.0-2



# End Of Year I

## Milestones:

- Establish haul ramp from pad 22 masl to 52 masl
- Perimeter screening berm begins
  - End of Yr 3 construction shown here

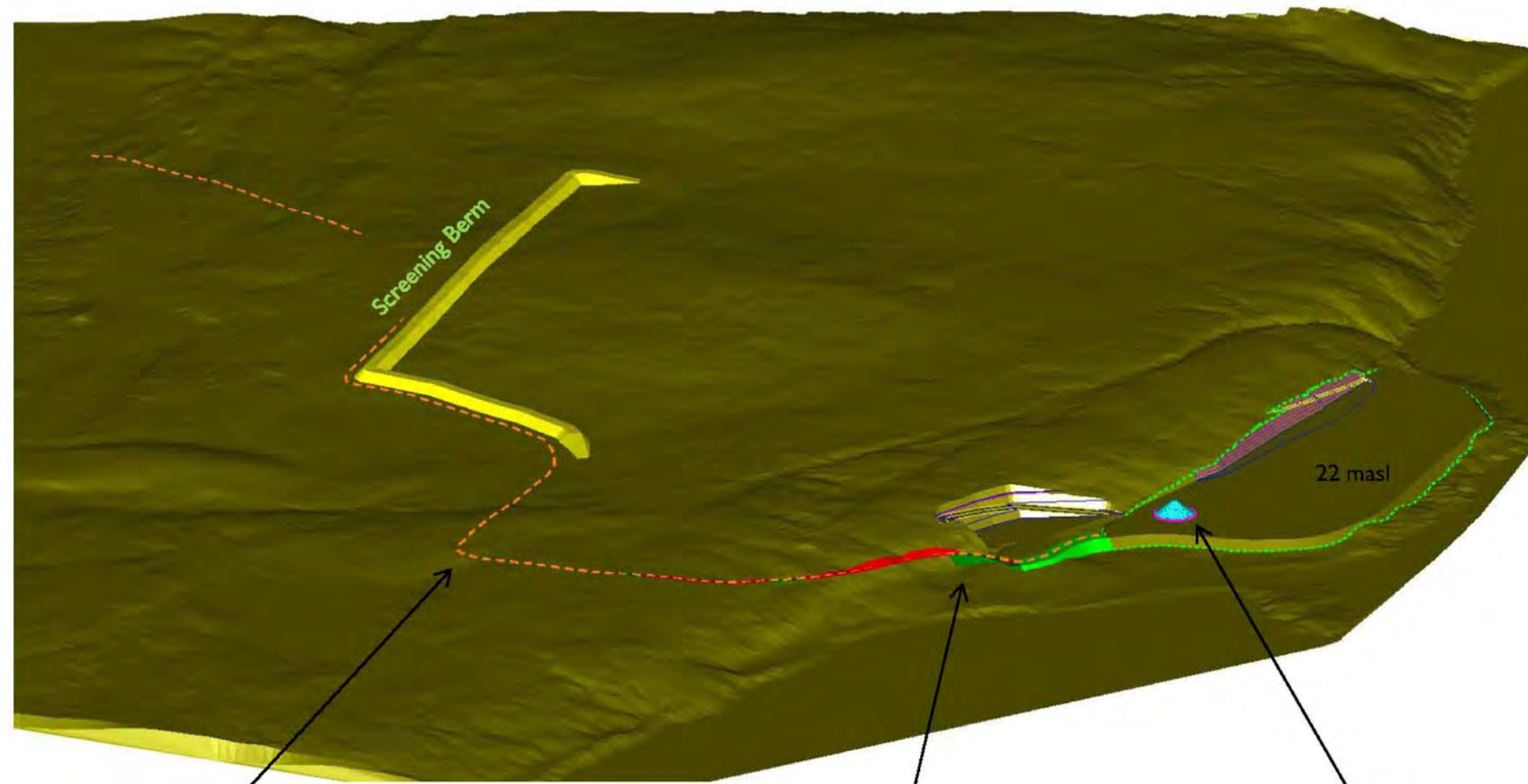

Entrance Road center line  
( Orange dotted line )

Cut ( Red ) and Fill ( Green )  
For entrance road construction

Phase 4 Primary Surge Pile  
Just for Reference

DATE	REVISION	BY	ISSUE DATE:





# End Of Year 2

## Milestones:

- Primary Station area completed ( dump and base )
- Ready for first pit sump construction
- Begin mining ridge to West
- Perimeter screening berm construction continues

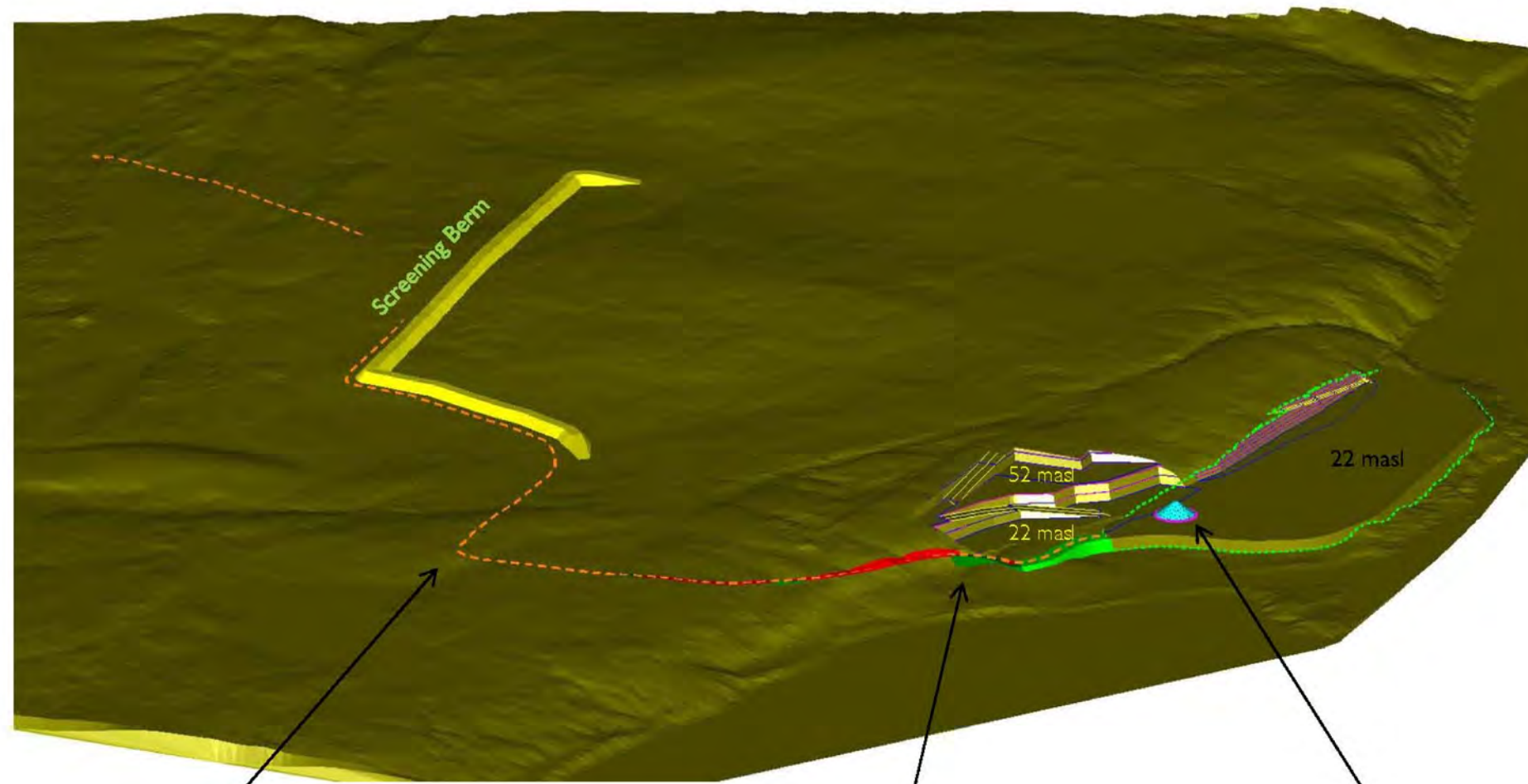

Entrance Road center line  
( Orange dotted line )

Cut ( Red ) and Fill ( Green )  
For entrance road construction

Phase 4 Primary Surge Pile  
Just for Reference

DATE	REVISION	BY	ISSUE DATE:

THIS DRAWING IN DESIGN AND DETAILS IS THE PROPERTY OF VULCAN MATERIALS COMPANY AND MUST BE RETURNED UPON DEMAND. THIS DRAWING MUST NOT BE COPIED, REPRODUCED, OR USED WITHOUT PERMISSION.



# End Of Year 3

## Milestones:

- First pit sump construction complete
  - 16.9 M gallon capacity
- Continue mining ridge to West
- Perimeter screening berm nearing completion
- Establish haul ramp down to 37 masl
  - Mining to get ready for main pit sump

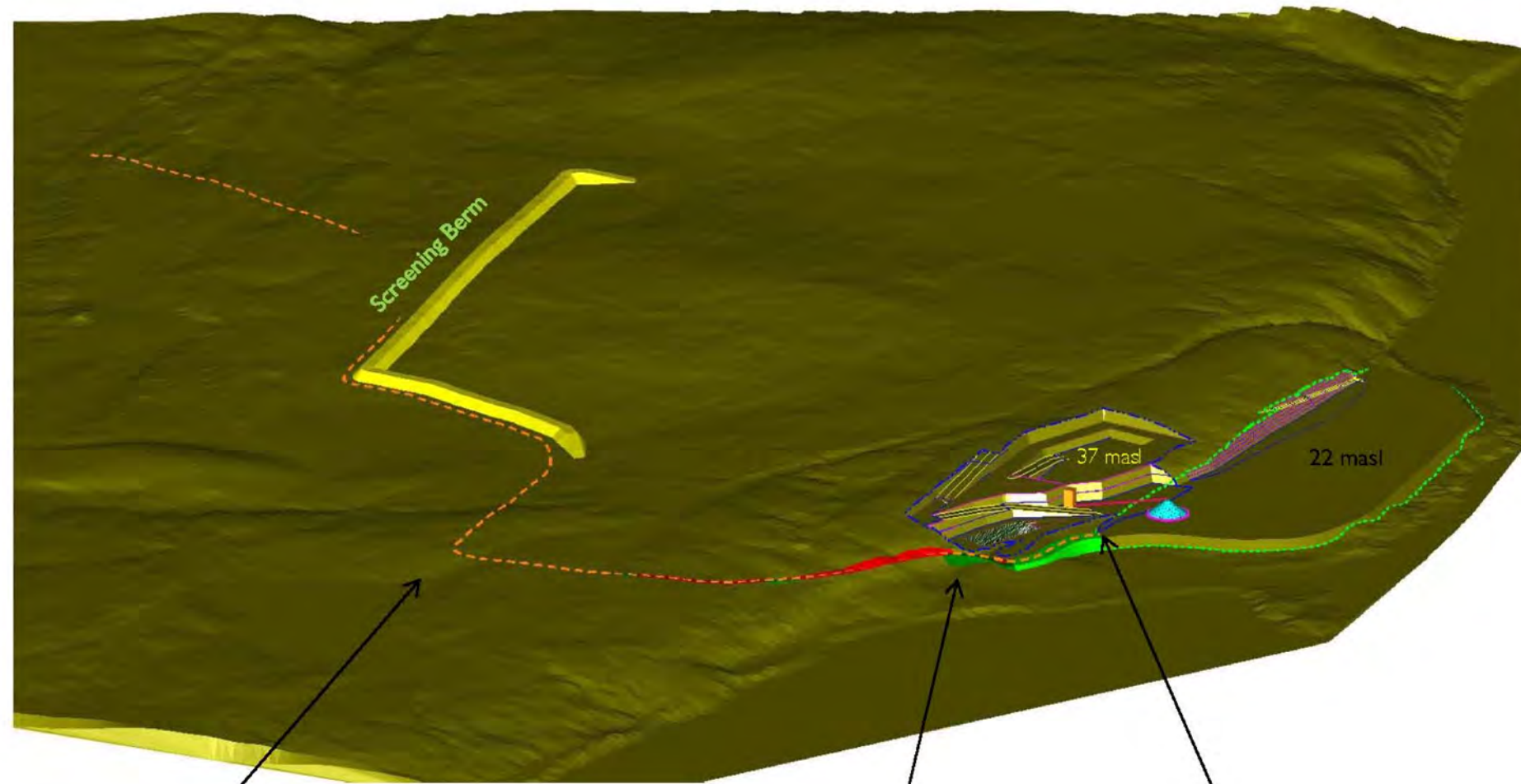

Entrance Road center line  
( Orange dotted line )

Cut ( Red ) and Fill ( Green )  
For entrance road construction

Phase 4 Primary Surge Pile  
Primary & Conveyor  
Just for Reference

DATE	REVISION	BY	ISSUE DATE:

THIS DRAWING IN DESIGN AND DETAILS IS THE PROPERTY OF VULCAN MATERIALS COMPANY AND MUST BE RETURNED UPON DEMAND. THIS DRAWING MUST NOT BE COPIED, REPRODUCED, OR USED WITHOUT PERMISSION.

End of Year 3	

REGION	NOVA SCOTIA	PLANT	BLACK POINT
DRAWN BY	BH	DATE	08/02/2012
CHECKED BY		SCALE	No scale
DWG. NO.			Figure 3.0-5





# End Of Year 4

## Milestones:

- Establish haul ramp down to 22 masl along ridge
- Main pit sump area is ready for construction
- Secondary waste storage pile begins

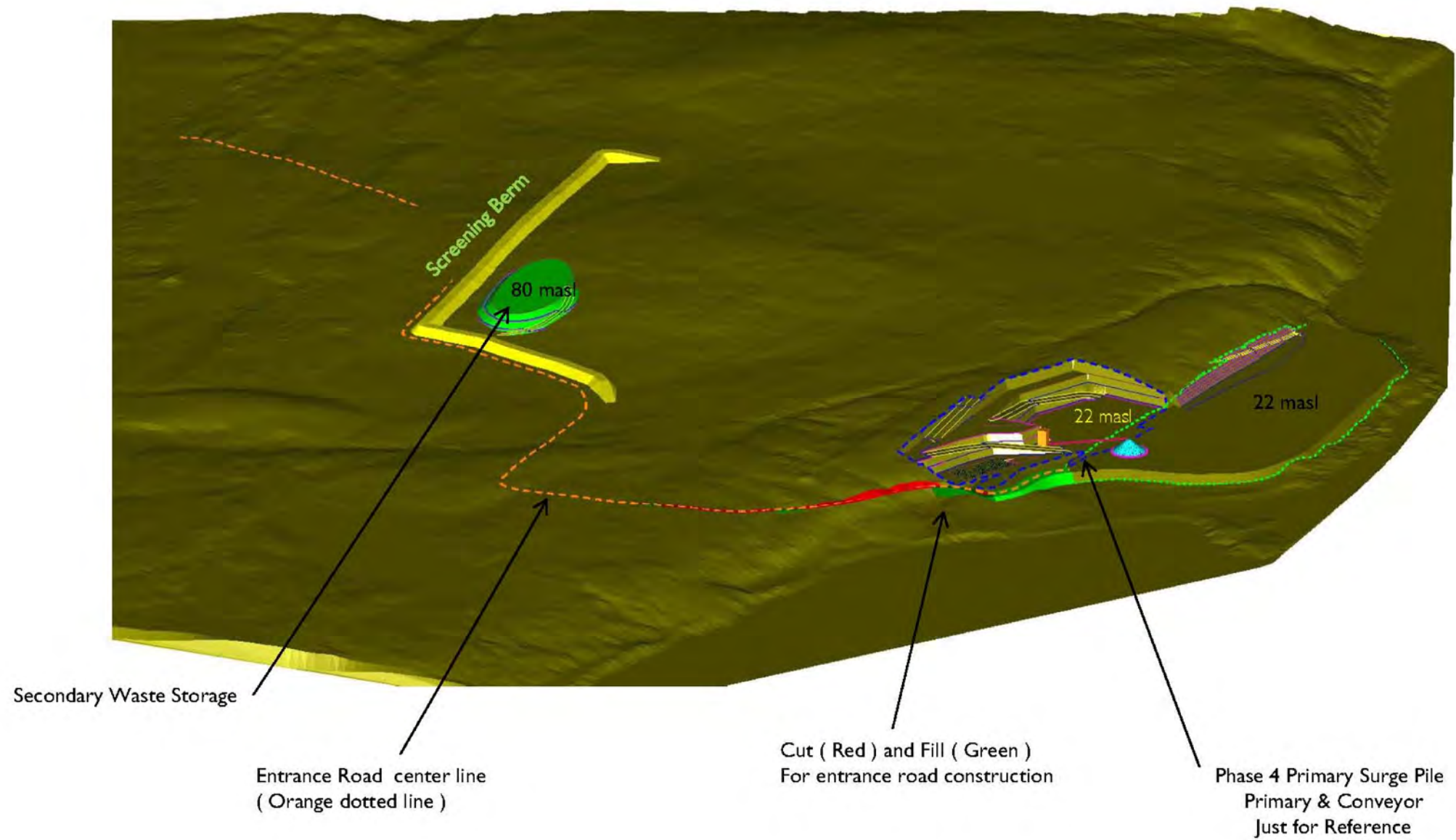

DATE	REVISION	BY	ISSUE DATE:





# End Of Year 5 11.8 MM Tons Mined

## Milestones:

- Main pit sump is complete
  - 102 M gallon capacity
- Area for initial waste pad completed
- Secondary waste pile completed

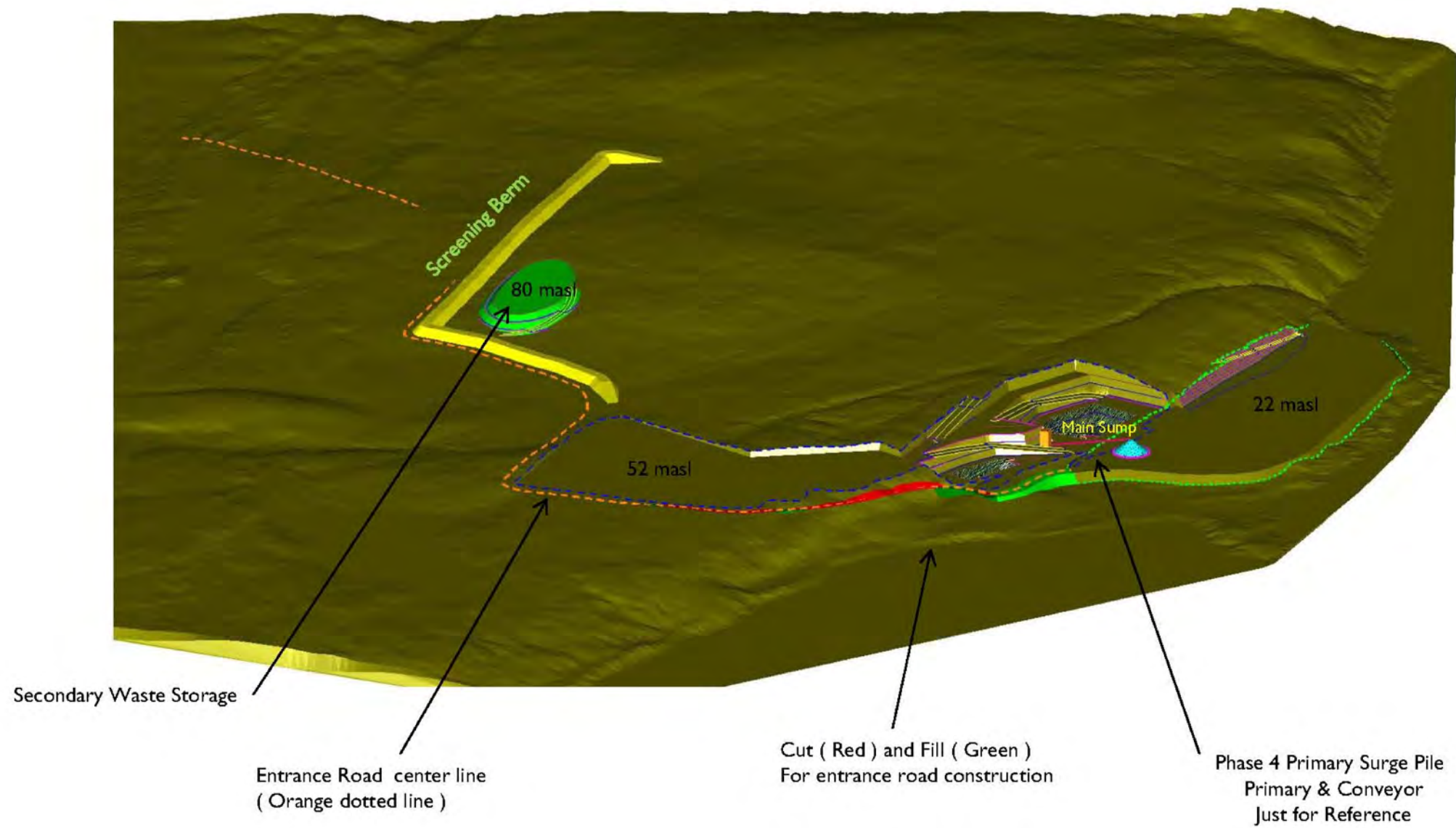

DATE	REVISION	BY	ISSUE DATE:



# 48.9 MM Tons Mined

## Milestones:

- Temporary Storage area for waste complete to 72 masl

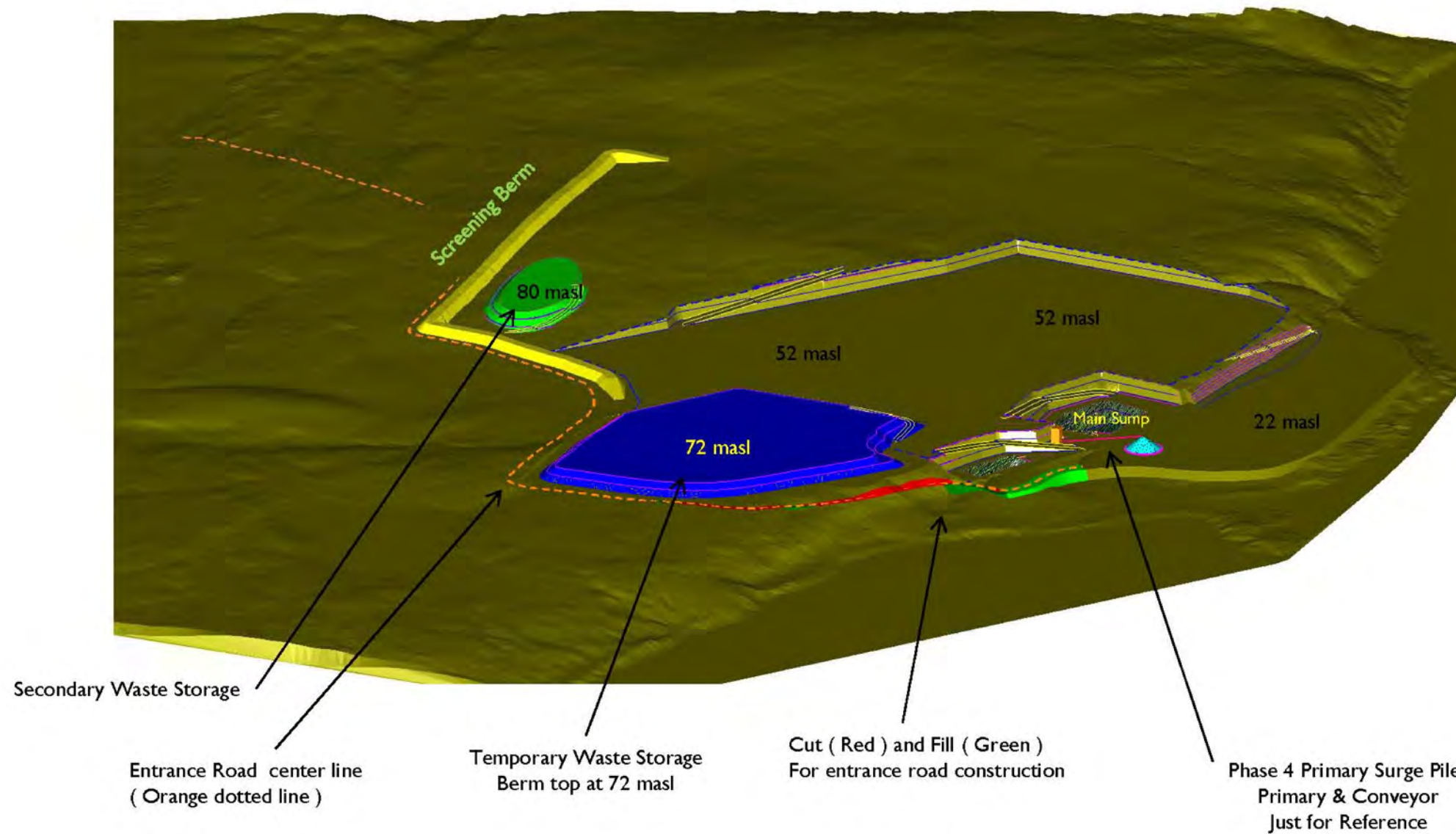

DATE	REVISION	BY	ISSUE DATE:





# 99.6 MM Tons Mined

## Milestones:

- Lowest point in pit -30 mbsl
- Ready for initial in pit waste disposal
- Waste berm foot print expanded and tops out at 82 masl
  - Three 10 m lifts

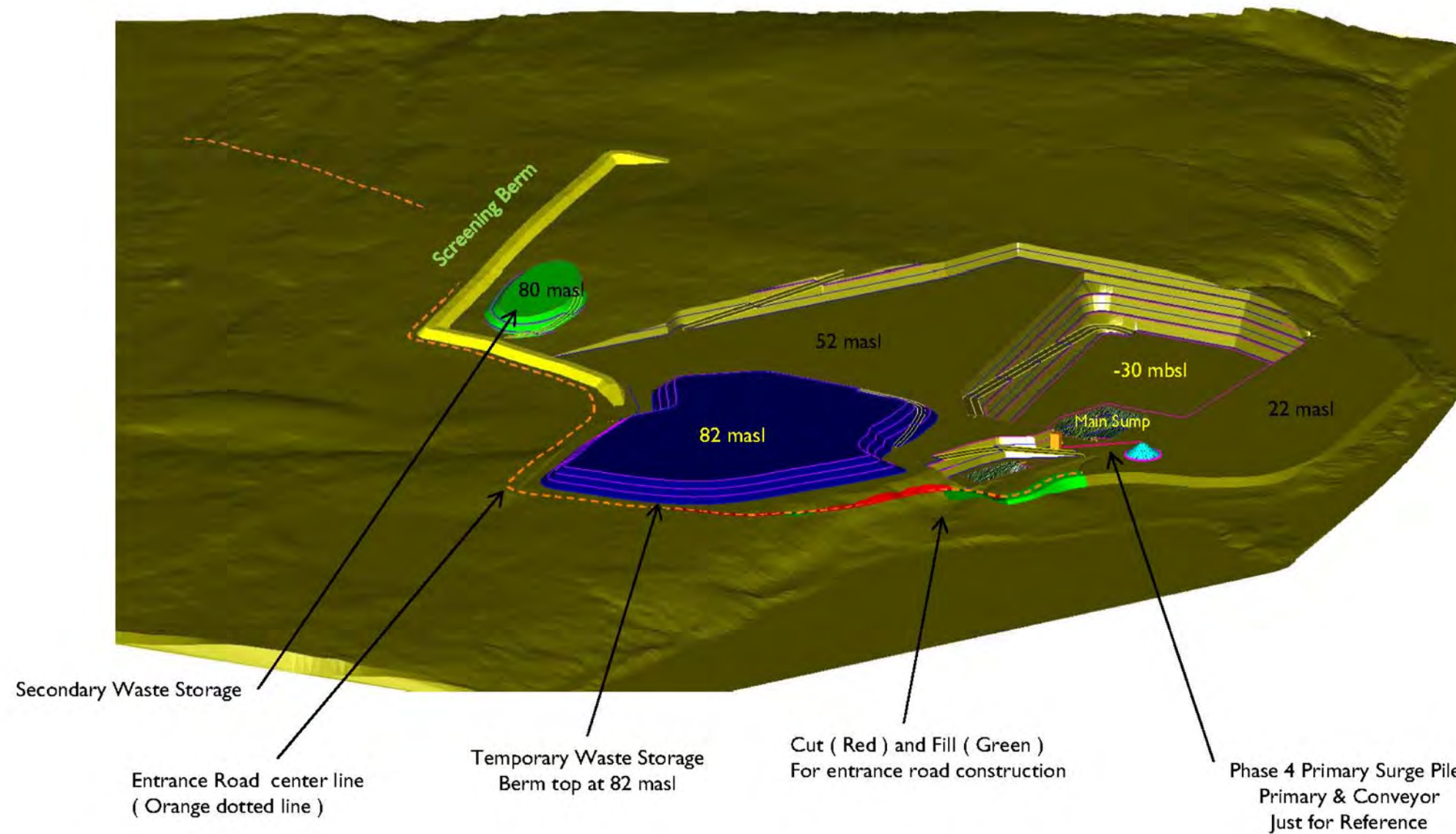

DATE	REVISION	BY	ISSUE DATE:



# 150.2 MM Tons Mined

## Milestones:

- Lowest point in pit at -30 mbsl
- Ready for additional in pit waste disposal

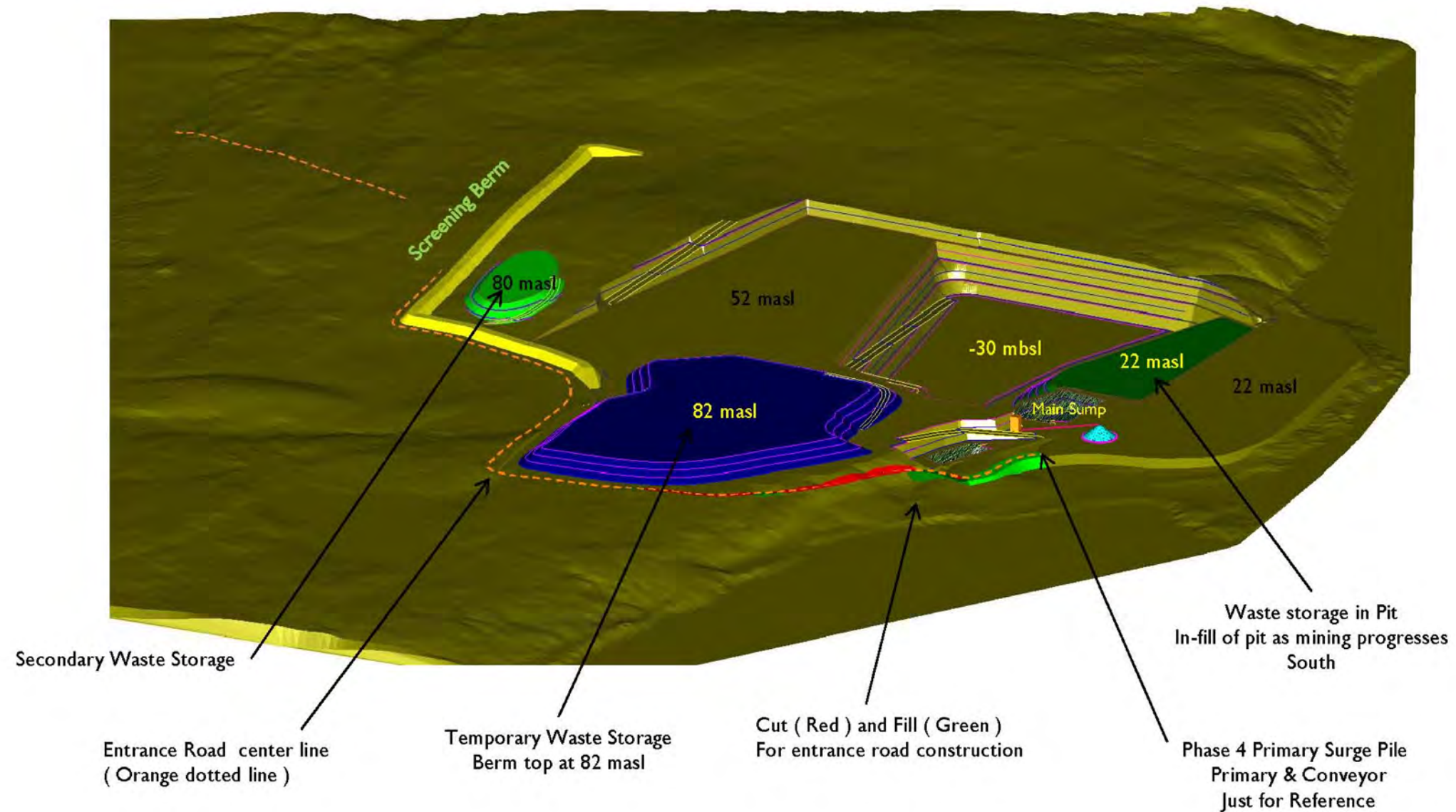

DATE	REVISION	BY	ISSUE DATE:

THIS DRAWING IN DESIGN AND DETAILS IS THE PROPERTY OF VULCAN MATERIALS COMPANY AND MUST BE RETURNED UPON DEMAND. THIS DRAWING MUST NOT BE COPIED, REPRODUCED, OR USED WITHOUT PERMISSION.





# 251.4 MM Tons Mined

## Milestones:

- South expansion complete to 7 masl
- Secondary waste storage relocated to pit
- Temporary waste storage relocation to pit begins
  - Option for early movement shown
- Lowest point in pit -30 mbsl

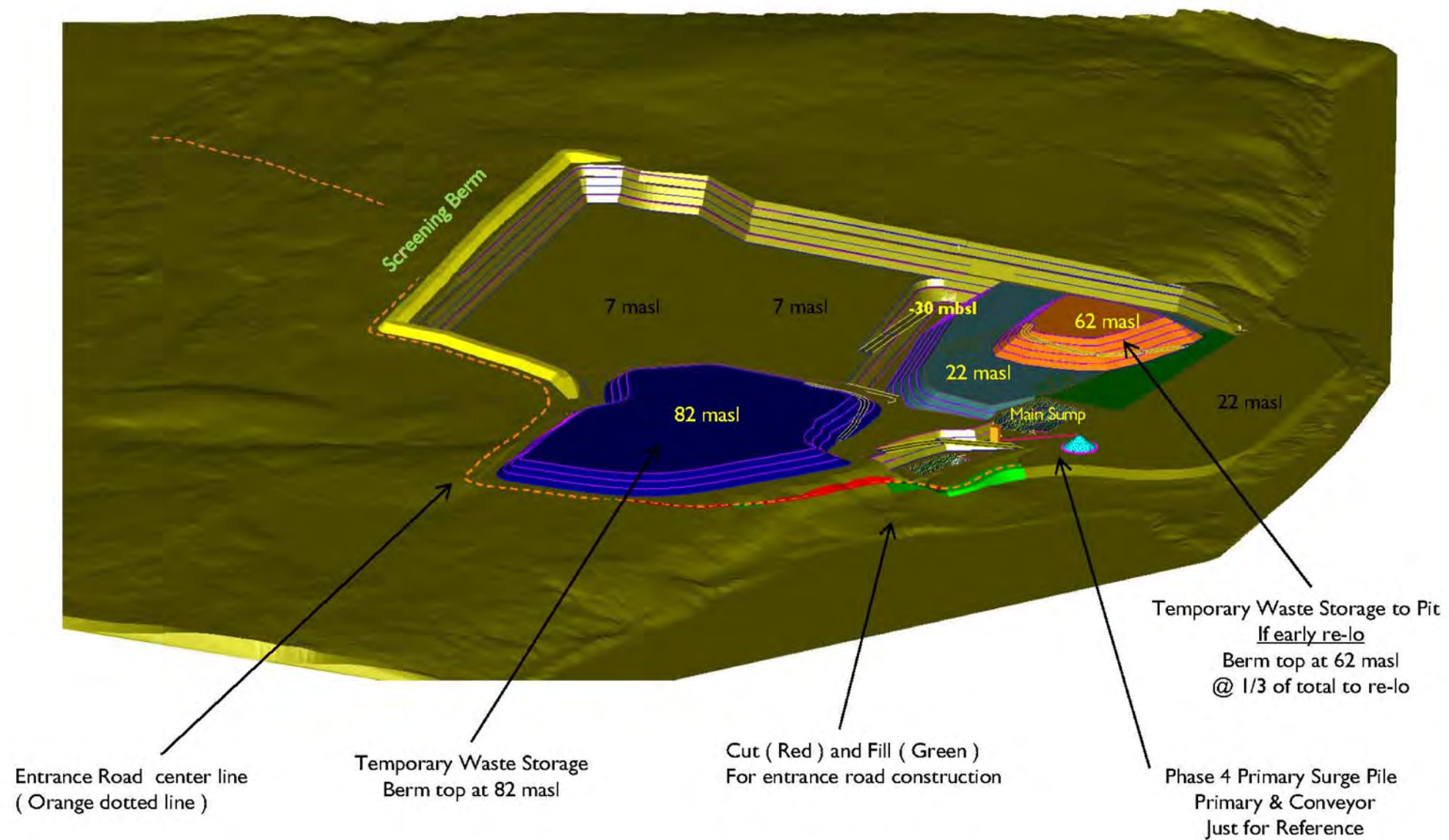



# 403.3 MM Tons Mined

## Milestones:

- Entire pit developed to -30 mbsl
- Main pit mined out to -30 mbsl
- Temporary Waste Storage is 100 % relocated to main pit
- See previous slide for alternative to in pit waste

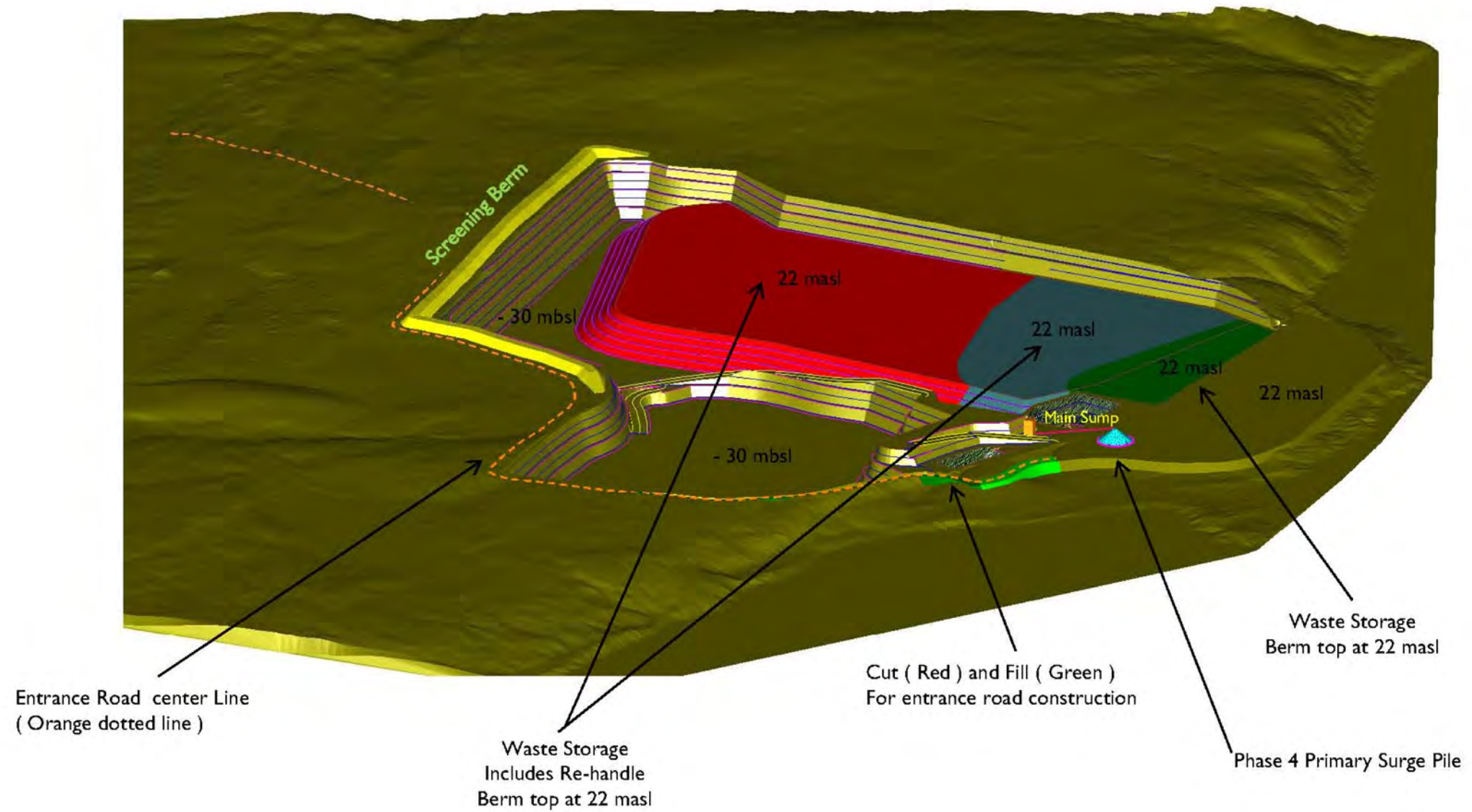

DATE	REVISION	BY	ISSUE DATE:

REGION	NOVA SCOTIA	PLANT	BLACK POINT
DRAWN BY	BH	DATE	10/22/2014
CHK BY		SCALE	No scale
JOB NO.		DWG. NO.	Figure 3.0-12
PATH			

### **3.1.3 Processing Plant**

Based upon the preliminary design, there will be five phases of the processing plant ranging from an initial portable circuit utilized for site development to a large fixed plant capable of producing an anticipated peak production of 7.5 MT. Process flow diagrams for each phase are included as **Figures 3.0-13, 3.0-14 and 3.0-15**. A description of each phase is given below.



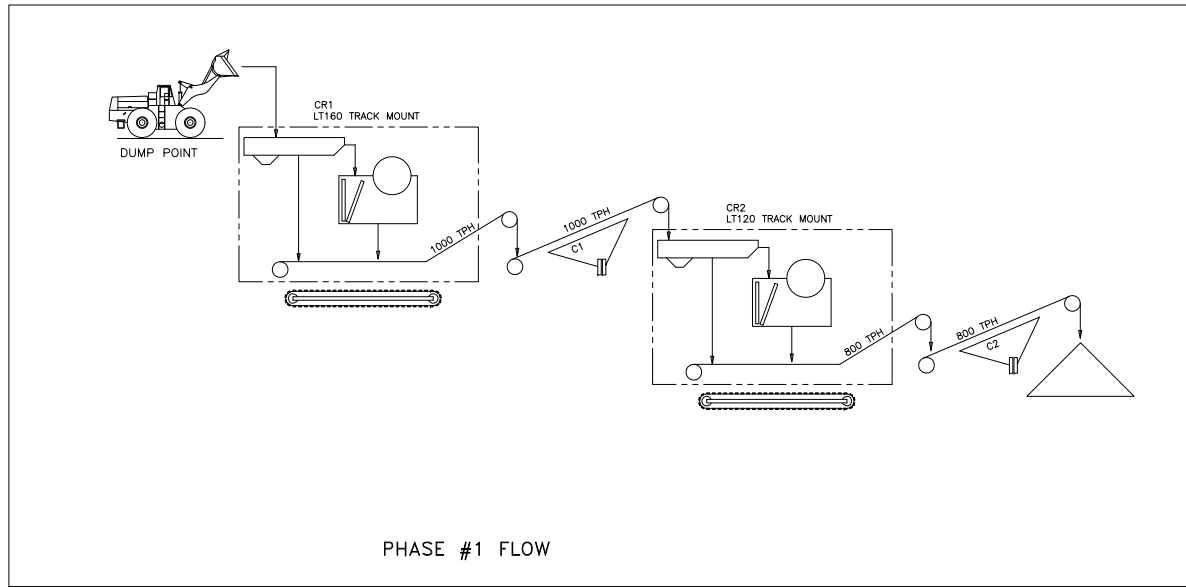

PHASE #1 FLOW

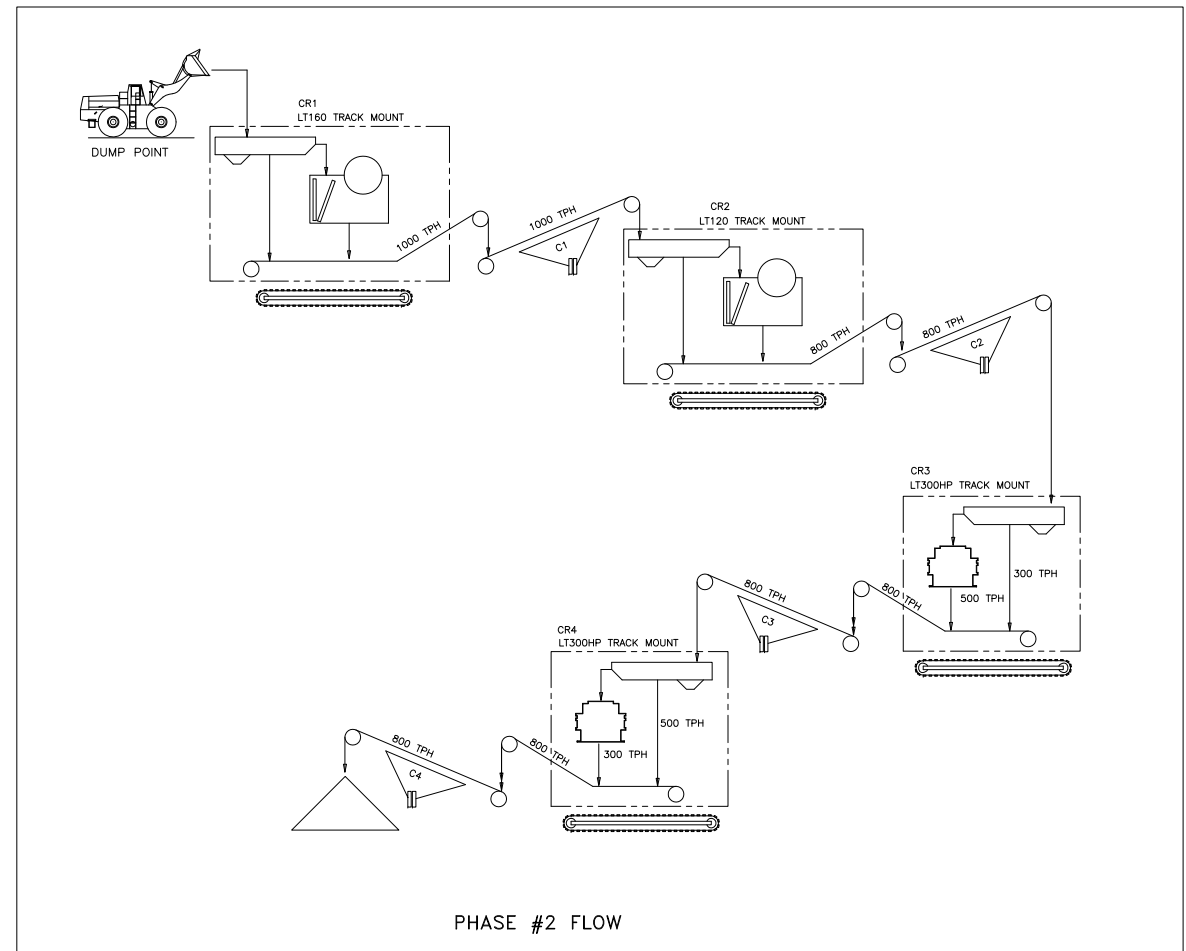

PHASE #2 FLOW

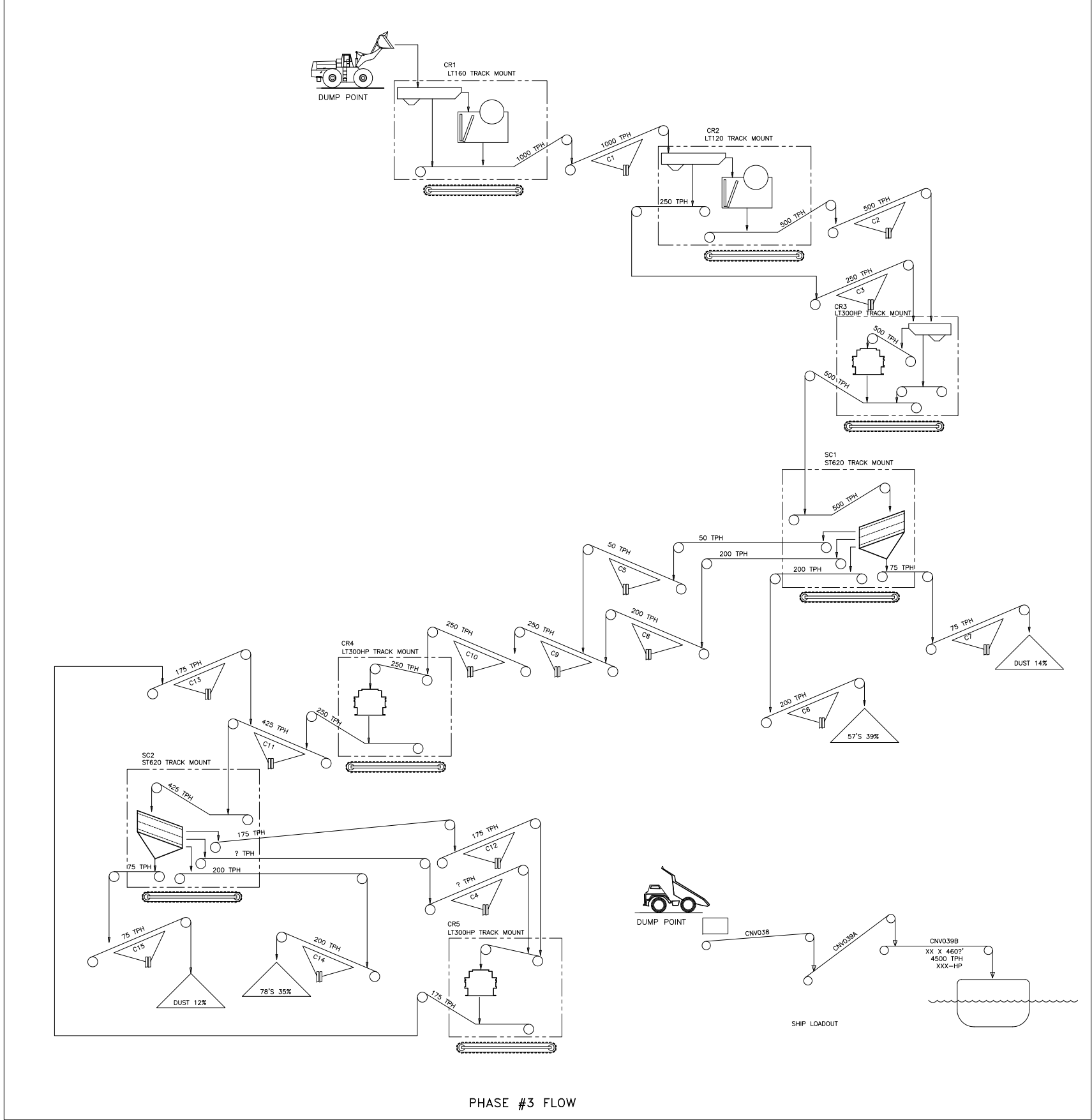

PHASE #3 FLOW

PROPOSED FLOW CHARTS  
 PRELIMINARY FLOW CHARTS BASED ON  
 THE EQUIPMENT SHOWN ON PLANT  
 LAYOUTS FIGURES 3-16, 3-17 & 3-18



D			
C			
B			
A			
-	INITIAL RELEASE		
-	DATE	REVISION	BY

TOLERANCES—UNLESS NOTED  
 FRACTIONAL: ± 1/16"  
 DECIMAL: ± 0.010"  
 ANGLE: ± 0.1°  
 THIS DRAWING IN DESIGN AND DETAIL IS THE  
 PROPERTY OF VULCAN MATERIALS COMPANY  
 AND MUST BE RETURNED UPON DEMAND. THIS  
 DRAWING MUST NOT BE COPIED, REPRODUCED,  
 OR USED WITHOUT PERMISSION.



FLOW CHART	
PHASES 1, 2 & 3	

STATE	NOVA SCOTIA	PLANT	BLACK POINT
BY	CB	BY	LDJ
DATE	8/26/14	DATE	8/25/14
SCALE	NONE	SHEET	1 OF 1
FIGURE 3.0-13			REV





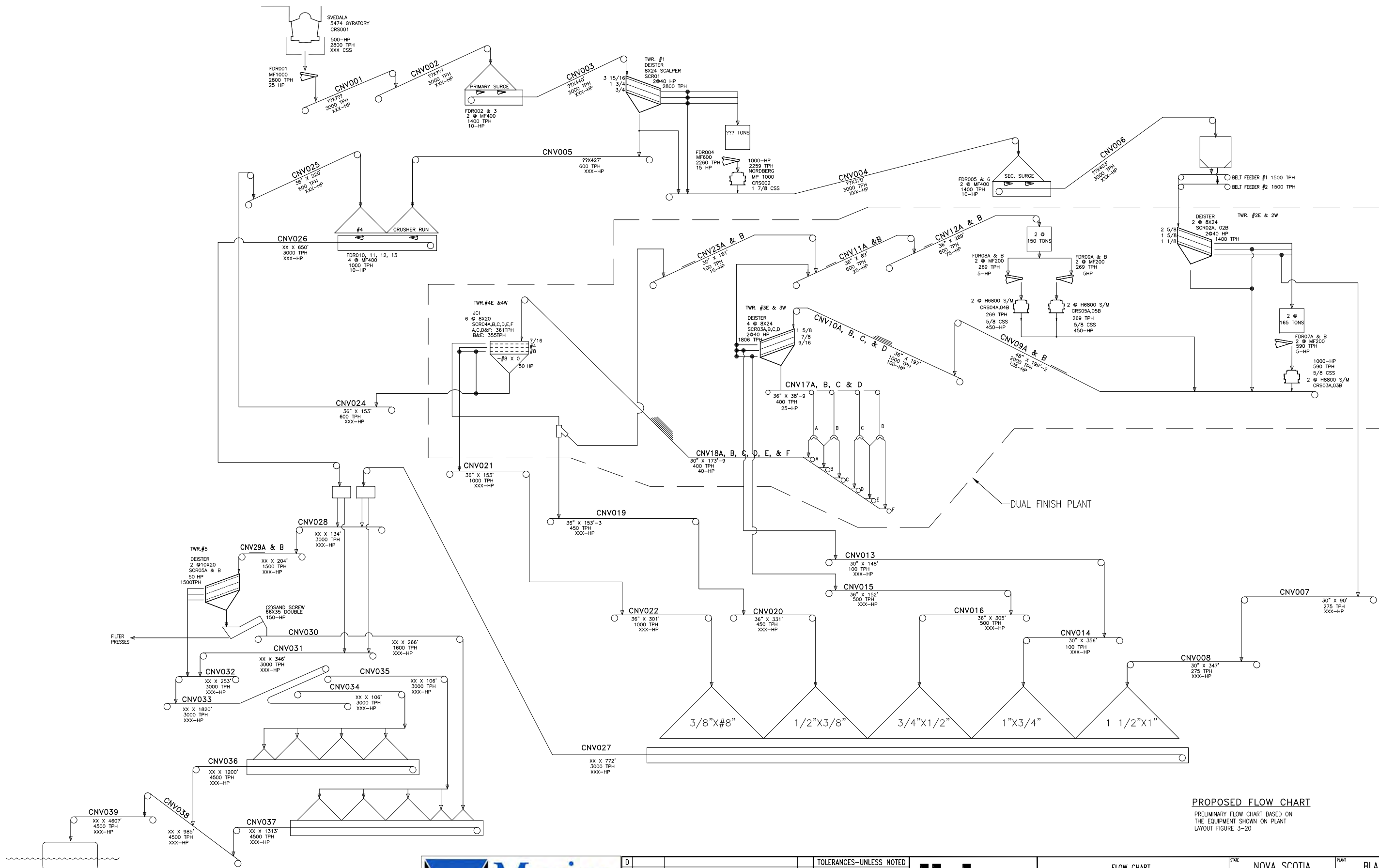

**PROPOSED FLOW CHART**

PRELIMINARY FLOW CHART BASED ON THE EQUIPMENT SHOWN ON PLANT LAYOUT FIGURE 3-20



**TOLERANCES—UNLESS NOTED**  
 FRACTIONAL: ± 1/16"  
 DECIMAL: ± 0.010"  
 ANGLE: ± 0.1°



FLOW CHART	PHASE 5
------------	---------

STATE	NOVA SCOTIA	PLANT	BLACK POINT
BY	CB	BY	LDJ
DATE	8/19/14	DATE	8/25/14
SCALE	NONE	SHEET	1 OF 1
FIGURE	3.0-15	REV.	

D			
C			
B			
A			
	INITIAL RELEASE		
DATE	REVISION	BY	

### **Phase 1, Figure 3.0-16**

Major components:

- Two portable track mounted primary crushing plants that include vibrating grizzly feeders.
- Conveyors.

A small portable or mobile plant with a capacity up to 1,000 tons per hour (TPH) will be utilized for initial plant site development. This plant will produce a coarse fill material for site development needs (i.e., road, berm and platform construction). Power for the plant will be provided by diesel powered generators with capacities of either 200 kW or 525 kW depending on whether electricity is available to power the non-motive portion of the plant.

During development of the plant site situated on the lower coastal platform, the grade will be sloped away from the coast and wetlands and toward stormwater retention basins first located near the center of the coastal platform (Figures 3.0-16) and in later phases situated at the foot the cliff (**Figures 3.0-17 and 3.0-18**). These basins are designed to retain stormwater to allow for clarification prior to discharge the marine environment, if needed.

In this plant, blasted material will be trucked to the mobile plant and dumped adjacent to the primary module. A loader will then feed the material into the processing plant. The coarse fill material will be stockpiled by conveyor.

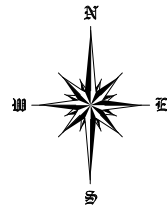

CHEDABUCTO BAY

PRELIMINARY EQUIPMENT LIST				
Crusher Plant	Model Number	Description	Crusher Model	Power
CR1	LT160	Track Mounted Crushing Plant	C160	Diesel
CR2	LT120	Track Mounted Crushing Plant	C120	Diesel

Conveyors	
Conveyor Number	Description
C1	CR1 to CR2
C2	Product Stacker

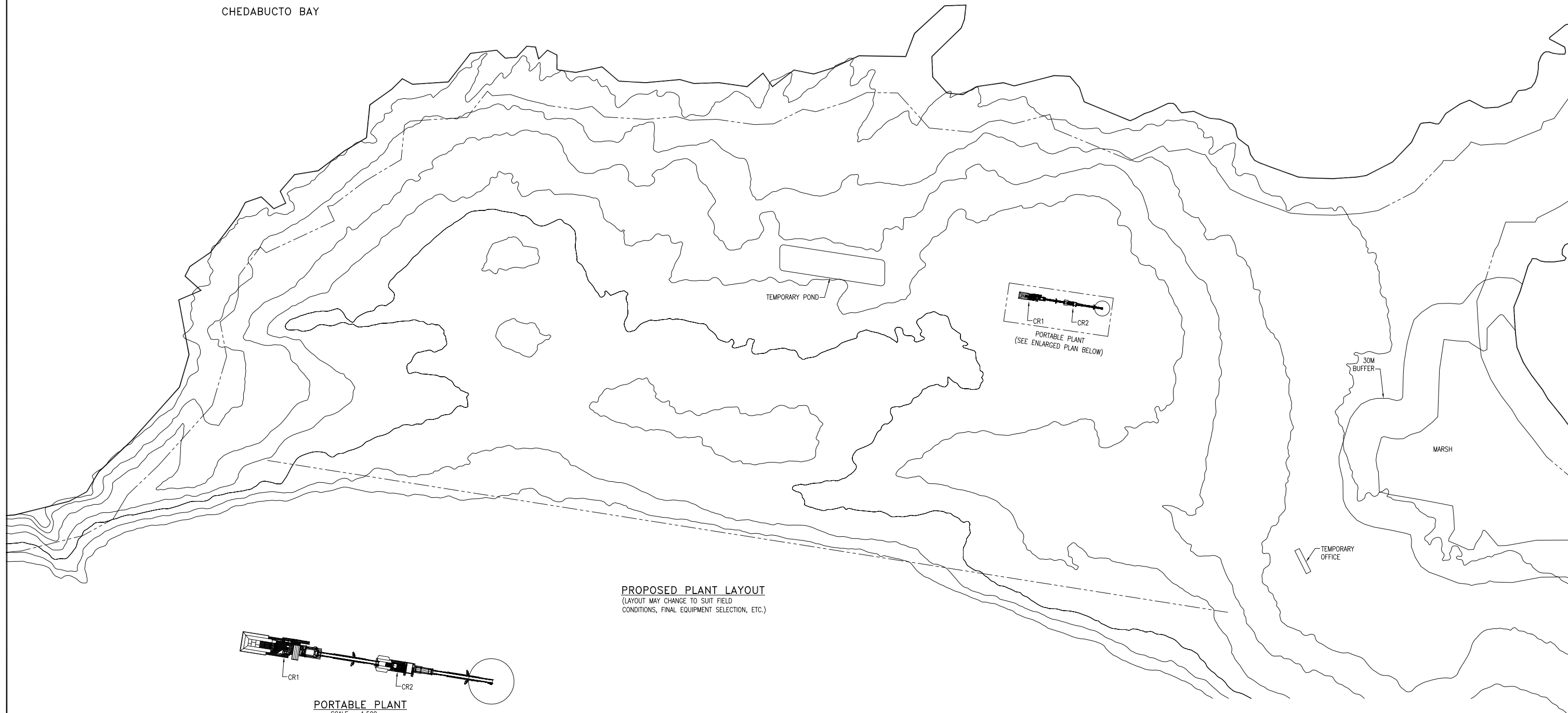

**PROPOSED PLANT LAYOUT**  
 (LAYOUT MAY CHANGE TO SUIT FIELD CONDITIONS, FINAL EQUIPMENT SELECTION, ETC.)

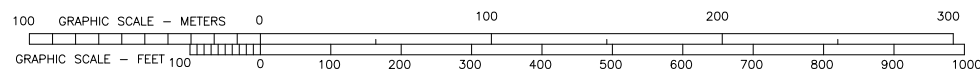
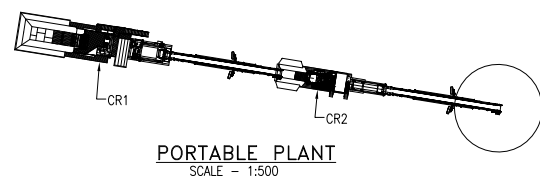

D			
C			
B			
A			
-	INITIAL RELEASE		
-	DATE	REVISION	BY

**TOLERANCES—UNLESS NOTED**  
 FRACTIONAL: ± 1/16"  
 DECIMAL: ± 0.010"  
 ANGLE: ± 0.1°

THIS DRAWING IN DESIGN AND DETAIL IS THE PROPERTY OF VULCAN MATERIALS COMPANY AND MUST BE RETURNED UPON DEMAND. THIS DRAWING MUST NOT BE COPIED, REPRODUCED, OR USED WITHOUT PERMISSION.



PLANT LAYOUT (PHASE 1)	

STATE	NOVA SCOTIA	PLANT	BLACK POINT
BY	CB	BY	LJ
DATE	6/27/14	DATE	9/15/14
SCALE	1 : 1500	SHEET	1 OF 1
FIGURE 3.0-16			REV

### **Phase 2, Figure 3.0-17**

Major components:

- Phase 1 equipment described above.
- Two portable track mounted secondary crushing plants that include vibrating feeders.
- Conveyors.

In the second phase plant, two additional track mounted crushing modules will be added to the Phase 1 equipment; the modules will have a similar capacity to that described for Phase 1. This plant will produce a fine graded fill material for final site development needs. Power for this plant will be provided by diesel powered generators built into the track mounted crushing units.

During final development of the site, the grade will be sloped away from the coast and wetlands and toward a permanent stormwater retention basin built against the cliff. This will prevent uncontrolled stormwater discharges to the marine environment.

Marine terminal construction is expected to begin during Phase 2 as described in Section 3.2.6.

Operation of this plant will be identical to that of the Phase 1 plant. The fine graded fill material will be stockpiled by conveyor and no washing of aggregate will occur during Phase 1 or Phase 2. All material produced will be a base or crusher run product.



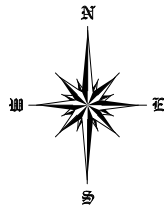

CHEDABUCTO BAY

PRELIMINARY EQUIPMENT LIST				
Crusher Plant	Model Number	Description	Crusher Model	Power
CR1	LT160	Track Mounted Crushing Plant	C160	Diesel
CR2	LT120	Track Mounted Crushing Plant	C120	Diesel
CR3	LT300HP	Track Mounted Crushing Plant	HP300	Diesel
CR4	LT300HP	Track Mounted Crushing Plant	HP300	Diesel

Conveyors	
Conveyor Number	Description
C1	CR1 to CR2
C2	CR2 to CR3
C3	CR3 to CR4
C4	Product Stacker

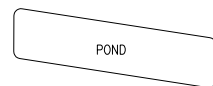
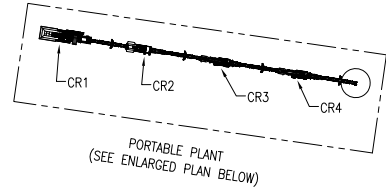

30M BUFFER

MARSH

TEMPORARY OFFICE

PROPOSED PLANT LAYOUT  
(LAYOUT MAY CHANGE TO SUIT FIELD CONDITIONS, FINAL EQUIPMENT SELECTION, ETC.)

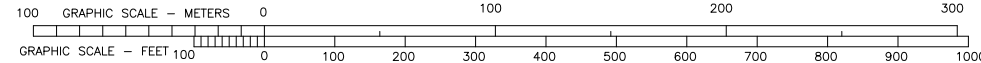
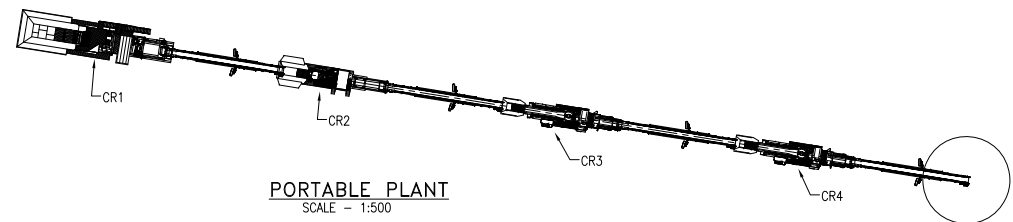

D			
C			
B			
A			
-	INITIAL RELEASE		
	DATE	REVISION	BY

TOLERANCES—UNLESS NOTED  
 FRACTIONAL: ± 1/16"  
 DECIMAL: ± 0.010"  
 ANGLE: ± 0.1°  
 THIS DRAWING IN DESIGN AND DETAIL IS THE PROPERTY OF VULCAN MATERIALS COMPANY AND MUST BE RETURNED UPON DEMAND. THIS DRAWING MUST NOT BE COPIED, REPRODUCED, OR USED WITHOUT PERMISSION.



PLANT LAYOUT (PHASE 2)	

STATE	NOVA SCOTIA	PLANT	BLACK POINT
BY	CB	BY	LJ
DATE	6/27/14	DATE	9/15/14
DWG. NO.		SCALE	1 : 1500
		SHEET	1 OF 1
		REV.	REV

FIGURE 3.0-17

### **Phase 3, Figure 3.0-18**

Major components:

- Phase 2 equipment described above.
- Two additional portable track mounted screening plants.
- One track mounted tertiary crushing plant with a belt feeder.
- Conveyors.

After the processing plant site has been developed, additional mobile units will be added to begin production to meet the initial sales demand. Power for the additional units will be supplied by diesel powered generators with combined capacity of 260 kW in addition to the existing generators identified as in Phases 1 and 2. Production during Phase 3 is expected to be approximately 500 TPH. This plant will be replaced by a larger fixed plant over time as the sales demand dictates. This approach is intended to save capital during the early years of the Project.

Operation of the Phase 3 plant will be similar to that of the earlier phases. In this plant, various products will be stockpiled via conveyor and trucked to the marine terminal. The conveyor feeding the ship loader will include a loadout hopper that can be charged with a plant loader.

The portable plant will be located in a portion of the plant site that will allow construction of the Phase 4 plant.

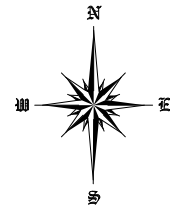

CHEDABUCTO BAY

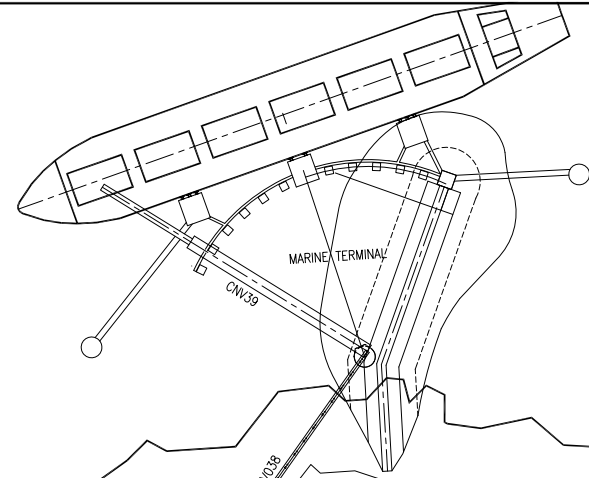

PRELIMINARY EQUIPMENT LIST				
Crusher Plant	Model Number	Description	Crusher Model	Power
CR1	LT160	Track Mounted Crushing Plant	C160	Diesel
CR2	LT120	Track Mounted Crushing Plant	C120	Diesel
CR3	LT300HP	Track Mounted Crushing Plant	HP300	Diesel
CR4	LT300HP	Track Mounted Crushing Plant	HP300	Diesel
CR5	LT300HP	Track Mounted Crushing Plant	HP300	Diesel
SCREEN PLANT	MODEL NUMBER	DESCRIPTION	SCREEN SIZE	POWER
SC1	ST620	TRACK MOUNTED SCREENING PLANT	6' X 20'	DIESEL
SC2	ST620	TRACK MOUNTED SCREENING PLANT	6' X 20'	DIESEL

Conveyors	
Conveyor Number	Description
C1	CR1 to CR2
C2	CR2 to CR3
C3	CR2 to CR3
C4 & C12	SC2 to CR5
C5	SC1 To C9
C6 & C7	Product Stackers
C8, C9 & C10	SC1 to CR4
C11	CR4 to SC2
C13	CR5 to C11
C14 & C15	Product Stackers

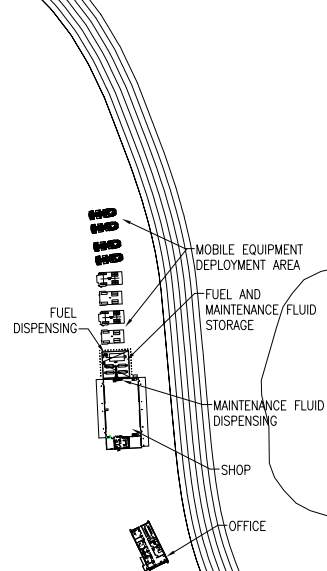
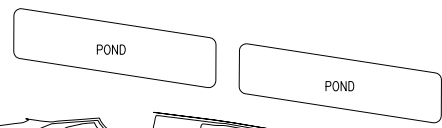
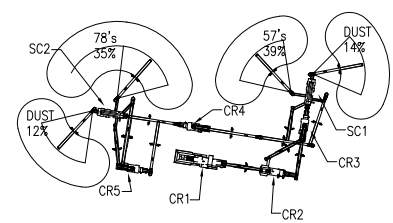

**PROPOSED PLANT LAYOUT**  
 (LAYOUT MAY CHANGE TO SUIT FIELD CONDITIONS, FINAL EQUIPMENT SELECTION, ETC.)

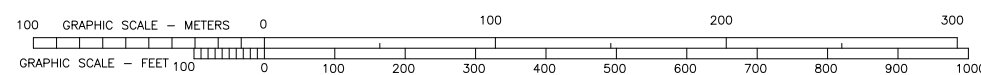

D			
C			
B			
A			
	INITIAL RELEASE		
	DATE	REVISION	BY

**TOLERANCES—UNLESS NOTED**  
 FRACTIONAL: ± 1/16"  
 DECIMAL: ± 0.010"  
 ANGLE: ± 0.1°

THIS DRAWING IN DESIGN AND DETAIL IS THE PROPERTY OF VULCAN MATERIALS COMPANY AND MUST BE RETURNED UPON DEMAND. THIS DRAWING MUST NOT BE COPIED, REPRODUCED, OR USED WITHOUT PERMISSION.



PLANT LAYOUT (PHASE 3)	
STATE	NOVA SCOTIA
PLANT	BLACK POINT
BY	CB
DATE	6/27/14
BY	LJ
DATE	9/15/14
SCALE	1 : 1500
SHEET	1 OF 1

FIGURE 3.0-18	REV
---------------	-----

#### **Phase 4, Figure 3-19**

Major components:

- Primary gyratory crusher.
- Primary surge reclaim tunnel.
- Scalping screen.
- Secondary cone crusher.
- Secondary surge reclaim tunnel.
- Six sizing screens.
- Three tertiary cone crushers.
- Conveyors.
- Vibratory feeders.
- Base/screenings reclaim tunnel.
- Fractionated products reclaim tunnel.
- Two wash screens.
- Fines recovery system.
- Two sand screws.
- Two loadout reclaim tunnels.
- Marine terminal.

When the sales demand dictates a higher production rate, the mobile plant will be replaced by a larger fixed plant. The plant will have a flexible design that will allow it to be expanded as the market demand increases. The initial fixed plant will have the capability to produce up to 1,400 TPH through the tertiary plant.

In this plant, blasted material will be trucked to the primary crusher where it will be dumped into the primary hopper. There it will be crushed and conveyed to a primary surge pile located near the “secondary” where it will be fed into the plant. As the material is processed with further crushing and screening, it will be conveyed to product piles that are located over “reclaim” tunnels, that is, tunnels equipped with conveyor systems that allow the products to be moved. Products can then be reclaimed to the wash tower for rinsing or bypassed around it. Material will then be stockpiled over the loadout reclaim tunnels that will convey product to the marine terminal.

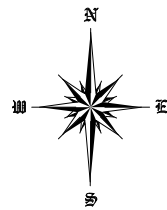

CHEDABUCTO BAY

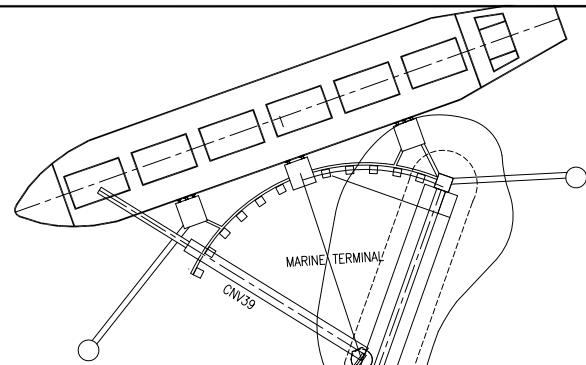

Screen Towers					Crushers						
Tower No.	Item No.	Description	Size	TPH	Total HP	Dwg. Label	Item No.	Description	Size	TPH	Total HP
ST1	SCR001	Scalping Screen	8x24 TD	2800	80	C1	CRS001	Gyratory	54x74	2800	500
ST2W	SCR02B	Sizing Screen (West)	8x24 TD	1400	80	C2	CRS002	Secondary Standard	MP1000	2259	1000
ST3W	SCR03C	Sizing Screen (West)	8x24 TD	903	80	C3A	CRS03A	Tertiary Short Head (West)	H8800	590	1000
	SCR03D	Sizing Screen (West)	8x24 TD	903	80	C4A	CRS04A	Tertiary Short Head (West)	H6800	289	450
ST4W	SCR04D	Sizing Screen (West)	8x20 TD	361	50	C5A	CRS05A	Tertiary Short Head (West)	H6800	289	450
	SCR04E	Sizing Screen (West)	8x20 TD	355	50						
	SCR04F	Sizing Screen (West)	8x20 TD	361	50						
ST5	SCR05A	Wash Screen (South)	10x20 TD	1500	100						
	SCR05B	Wash Screen (North)	10x20 TD	1500	100						

Conveyors:	
Name	Description
CNV001	Primary Crusher to Transfer 1
CNV002	Transfer 1 to Primary Surge
CNV003	Primary Reclaim to Scalping Tower
CNV004	Scalping Tower to Secondary Surge
CNV005	Base Stackers
CNV006A & B	Secondary Surge Reclaim
CNV007	Tower 2 to CNV008 Stacker, 1 1/2x1
CNV008	Stacker, 1 1/2x1
CNV009A	Tertiary Discharge Belt To Transfer 1
CNV10A & B	Transfer 1 To Tower 3
CNV11A & CNV12A	Tower 3 to H6800 Crushers
CNV013, CNV014	Tower 3 to 1x3/4 Pile
CNV015, CNV016	Tower 3 to 3/4x1/2 Pile
CNV17A & B, CNV18A, B & C	Tower 3 to Tower 4
CNV019, CNV020	Tower 4 to CNV020 to 1/2x3/8 Pile
CNV021, CNV022	Tower 4 to CNV022 to 3/8x#8 Pile
CNV23A	Tower 4 to CNV011A & B
CNV024, CNV025	Tower 4 to Screenings Pile
CNV026	Base/Screenings Reclaim
CNV027	Fraction Reclaim
CNV028, CNV28A & B	Fraction Reclaim to Wash Tower
CNV030	Sand Screws to Reclaim
CNV031	Wash Tower Bypass Belt
CNV032	Wash Tower to Tripper
CNV033, CNV034, CNV035	Tripper and Stackers
CNV036, CNV037, CNV038	Reclaim to Ship Loader
CNV039	Ship Loader

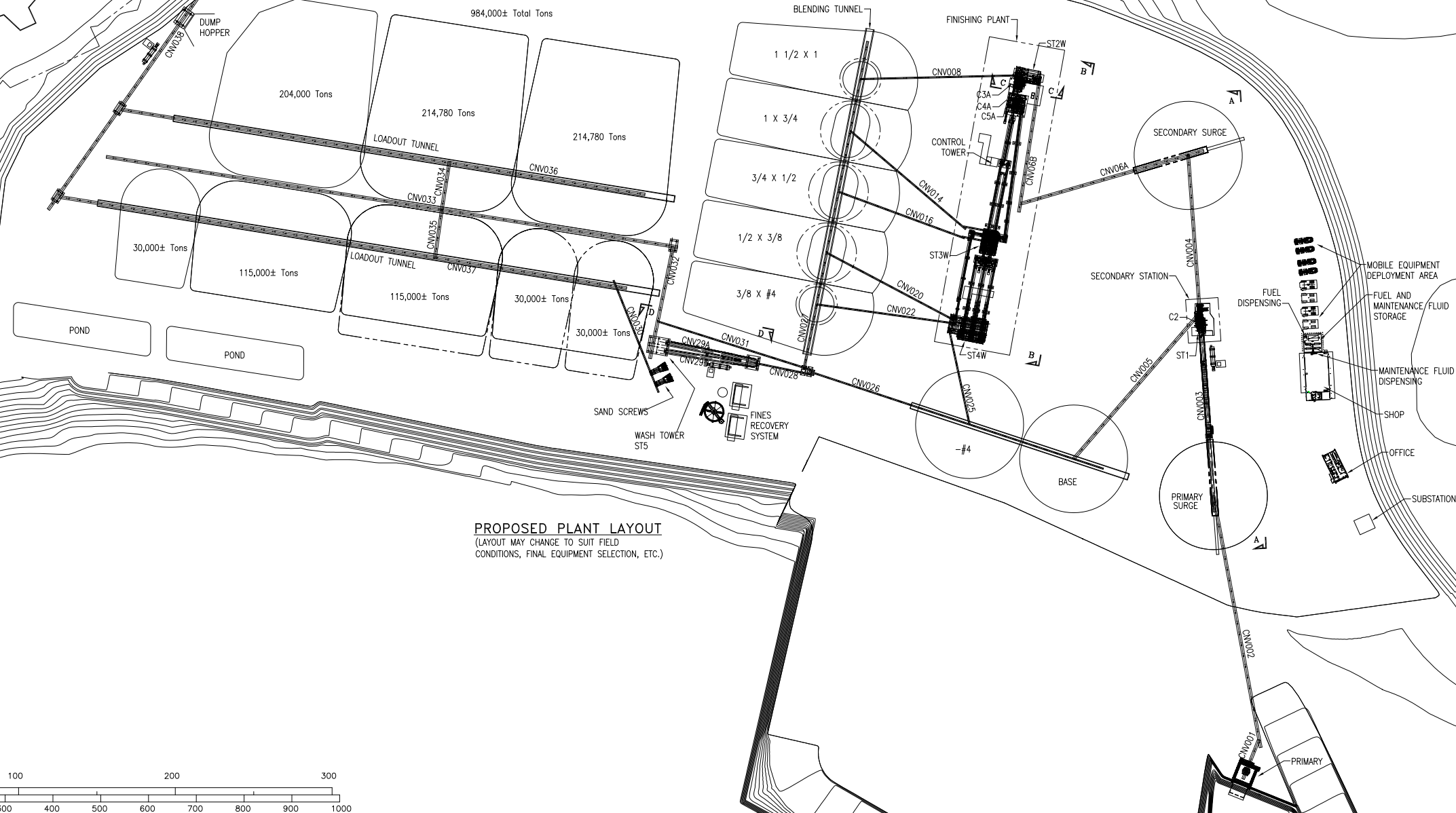

PROPOSED PLANT LAYOUT  
(LAYOUT MAY CHANGE TO SUIT FIELD CONDITIONS, FINAL EQUIPMENT SELECTION, ETC.)

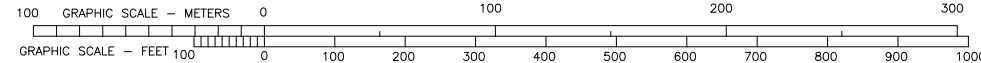

D			
C			
B			
A			
	INITIAL RELEASE		
DATE	REVISION	BY	

TOLERANCES—UNLESS NOTED  
 FRACTIONAL: ± 1/16"  
 DECIMAL: ± 0.010"  
 ANGLE: ± 0.1°  
 THIS DRAWING IN DESIGN AND DETAIL IS THE PROPERTY OF VULCAN MATERIALS COMPANY AND MUST BE RETURNED UPON DEMAND. THIS DRAWING MUST NOT BE COPIED, REPRODUCED, OR USED WITHOUT PERMISSION.



PLANT LAYOUT (PHASE 4)	
STATE	NOVA SCOTIA
PLANT	BLACK POINT
BY	CB
DATE	6/27/14
BY	LJ
DATE	9/15/14
SCALE	1 : 1500
SHEET	1 OF 1

FIGURE 3.0-19	REV
---------------	-----



The plant layout is designed in consideration of safe operational needs along with best practices developed over many years. The plant will be designed to minimize airborne dust emissions by utilizing built-in wet suppression for dust control. All structures will be designed according to appropriate building codes and engineering standards. Electrical power for the plant will be provided via Nova Scotia Power Inc. as described in Section 3.1.6.

### **Phase 5, Figure 3-20**

Major components:

- Phase 4 equipment described above.
- Six sizing screens.
- Three tertiary cone crushers.
- Conveyors.
- Vibratory feeders.

As the sales demand increases and production rates approach the limit of the initial fixed plant, the final phase will be initiated. This plant will upgrade the tertiary portion of the Phase 4 plant by installing a parallel tertiary processing circuit. Figure **3.0-21** provides plant elevations for the Phase 4 and 5 plants. Production through the finishing plant will be increased to 2,800 TPH.

Processing and loadout of the material will be identical to the Phase 4 plant but with a higher capacity. The parallel circuit will be identical to the original tertiary to minimize design time and costs. The layout will be located to minimize any operational disruptions due to the expansion.



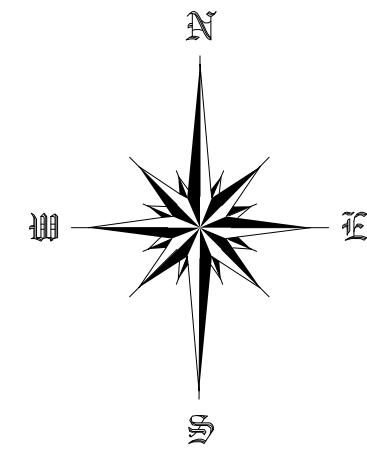

CHEDABUCTO BAY

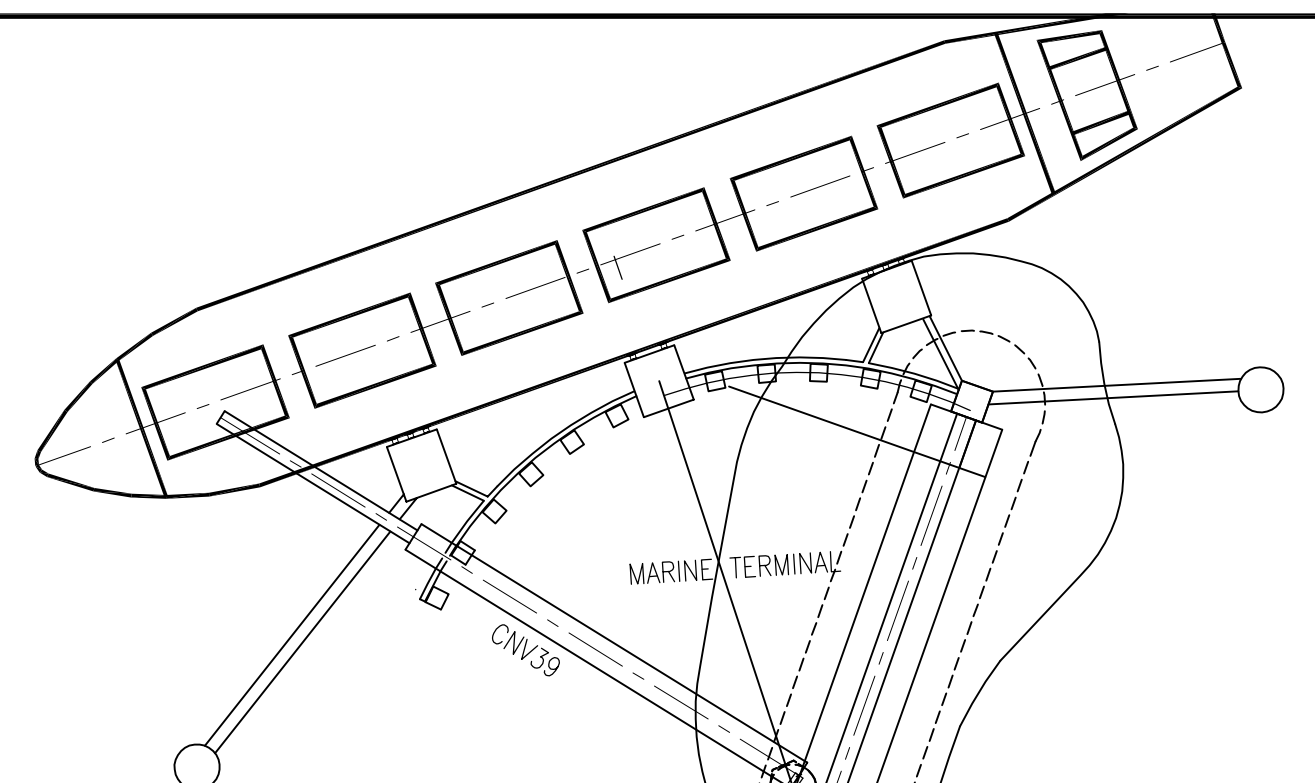

Screen Towers				
Tower No.	Item No.	Description	Size	Total HP
ST1	SCR001	Scalping Screen	8x24 TD	2800
ST2E	SCR02A	Sizing Screen (East)	8x24 TD	1400
ST3E	SCR03A	Sizing Screen (East)	8x24 TD	903
	SCR03B	Sizing Screen (East)	8x24 TD	903
ST4E	SCR04A	Sizing Screen (East)	8x20 TD	381
	SCR04B	Sizing Screen (East)	8x20 TD	355
	SCR04C	Sizing Screen (East)	8x20 TD	381
ST2W	SCR02B	Sizing Screen (West)	8x24 TD	1400
ST3W	SCR03C	Sizing Screen (West)	8x24 TD	903
	SCR03D	Sizing Screen (West)	8x24 TD	903
	SCR04D	Sizing Screen (West)	8x20 TD	381
ST4W	SCR04E	Sizing Screen (West)	8x20 TD	355
	SCR04F	Sizing Screen (West)	8x20 TD	381
ST5	SCR05A	Wash Screen (South)	10x20 TD	1500
	SCR05B	Wash Screen (North)	10x20 TD	1500

Crushers				
Dwg. Label	Item No.	Description	Size	Total HP
C1	CRS001	Gyratory	54x74	2800
C2	CRS002	Secondary Standard	MP1000	2259
C3A	CRS03A	Tertiary Short Head (West)	H8800	590
C4A	CRS04A	Tertiary Short Head (West)	H8800	269
C5A	CRS05A	Tertiary Short Head (West)	H8800	269
C3B	CRS03B	Tertiary Short Head (East)	H8800	590
C4B	CRS04B	Tertiary Short Head (East)	H8800	269
C5B	CRS05B	Tertiary Short Head (East)	H8800	269

Conveyors:	
Name	Description
CNV001	Primary Crusher to Transfer 1
CNV002	Transfer 1 to Primary Surge
CNV003	Primary Reclaim to Scalping Tower
CNV004	Scalping Tower to Secondary Surge
CNV005	Base Stacker
CNV006A & B	Secondary Surge Reclaim
CNV007	Tower 2 to CNV008 Stacker, 1 1/2x1
CNV008	Stacker, 1 1/2x1
CNV009A & B	Tertiary Discharge Belt To Transfer 1
CNV10A, B, C & D	Transfer 1 To Tower 3
CNV11A & B, CNV12A & B	Tower 3 to H8800 Crushers
CNV013, CNV014	Tower 3 to 1x3/4 Pile
CNV015, CNV016	Tower 3 to 3/4x1/2 Pile
CNV17A thru D, CNV18A thru F	Tower 3 to Tower 4
CNV019, CNV020	Tower 4 to CNV020 to 1/2x3/8 Pile
CNV021, CNV022	Tower 4 to CNV022 to 3/8x#8 Pile
CNV23A & B	Tower 4 to CNV011A & B
CNV024, CNV025	Tower 4 to Screenings Pile
CNV026	Base/Screenings Reclaim
CNV027	Fraction Reclaim
CNV028, CNV29A & B	Fraction Reclaim to Wash Tower
CNV030	Sand Screws to Reclaim
CNV031	Wash Tower Bypass Belt
CNV032	Wash Tower to Tripper
CNV033, CNV034, CNV035	Tripper and Stackers
CNV036, CNV037, CNV038	Reclaim to Ship Loader
CNV039	Ship Loader

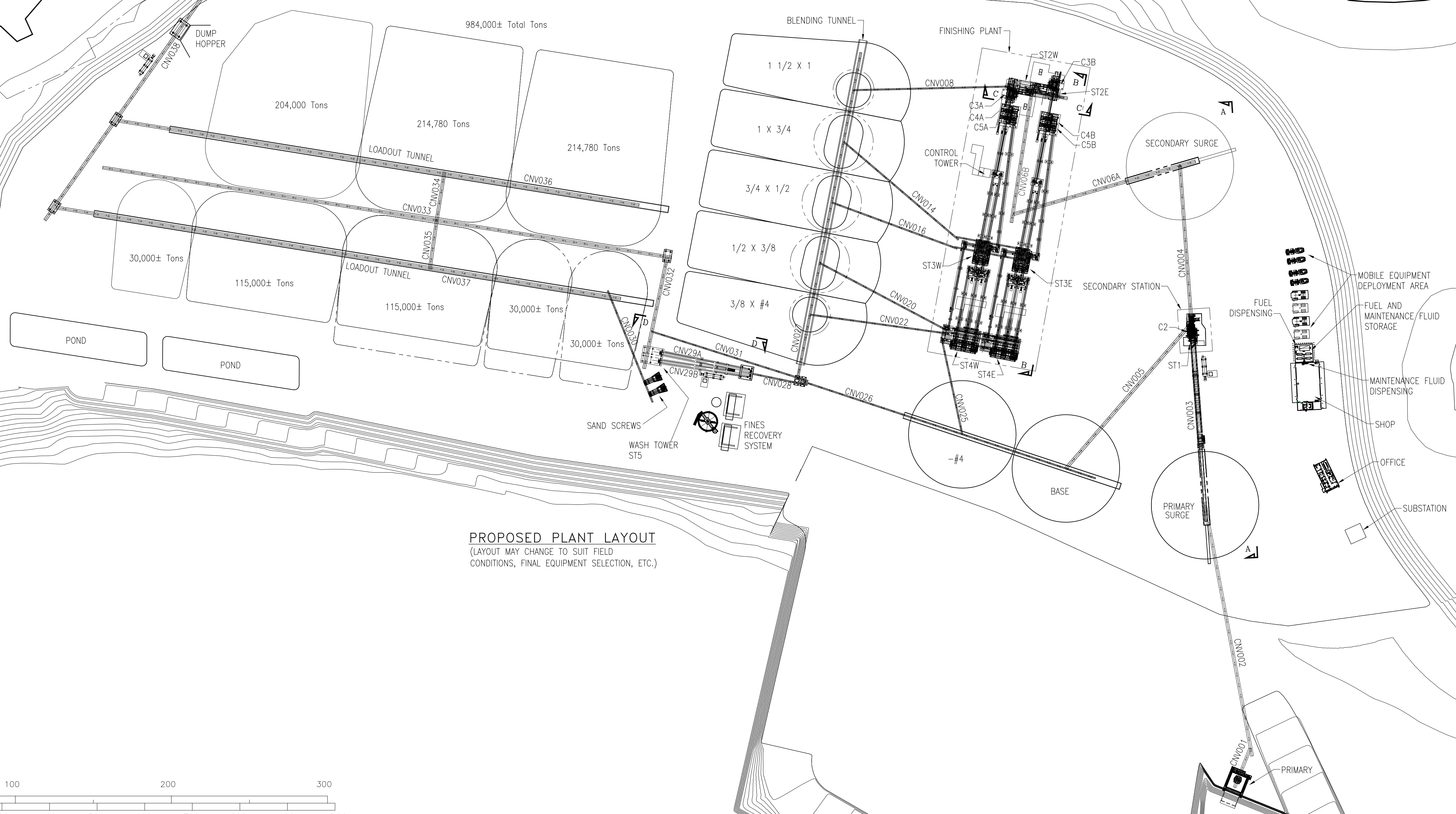

PROPOSED PLANT LAYOUT  
(LAYOUT MAY CHANGE TO SUIT FIELD CONDITIONS, FINAL EQUIPMENT SELECTION, ETC.)

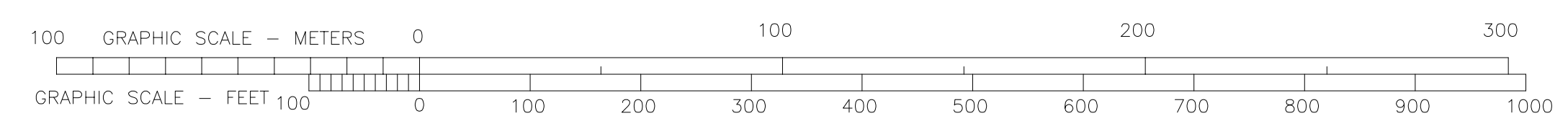

D			
C			
B			
A			
	INITIAL RELEASE		
	DATE	REVISION	BY

TOLERANCES—UNLESS NOTED  
 FRACTIONAL: ± 1/16"  
 DECIMAL: ± 0.010"  
 ANGLE: ± 0.1°  
 THIS DRAWING IN DESIGN AND DETAIL IS THE PROPERTY OF VULCAN MATERIALS COMPANY AND MUST BE RETURNED UPON DEMAND. THIS DRAWING MUST NOT BE COPIED, REPRODUCED, OR USED WITHOUT PERMISSION.



PLANT LAYOUT (PHASE 5)	
DATE	NOVA SCOTIA
BY	BLACK POINT
DATE	PROJ. NO.
DATE	FILE SERVER
DATE	SCALE
DATE	SHEET 1 OF 1

DATE	NOVA SCOTIA	PLANT	BLACK POINT
BY	CB	FILE SERVER	
DATE	6/27/14	SCALE	1 : 1500
DATE	9/15/14	SHEET	1 OF 1
DATE		REV	

FIGURE 3.0-20

REV



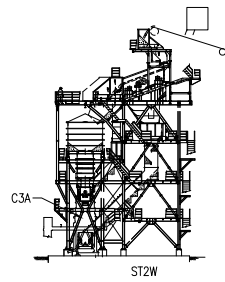

ELEVATION "C-C"  
PHASE #4

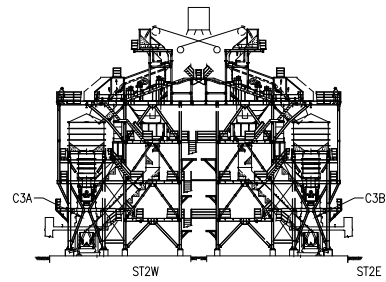

ELEVATION "C-C"  
PHASE #5

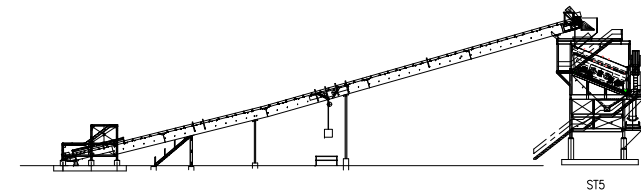

ELEVATION "D-D"

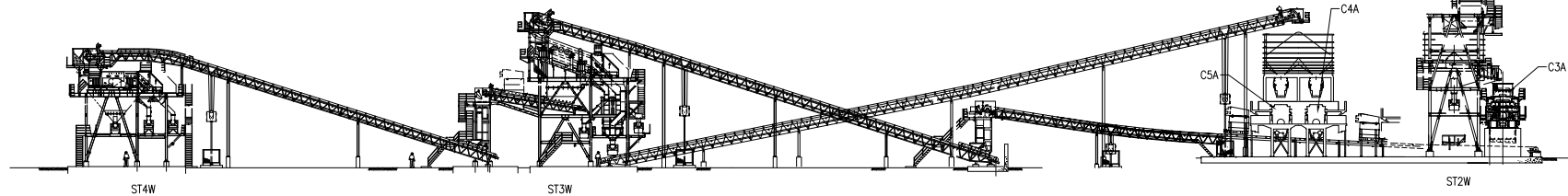

ELEVATION "B-B"  
PHASE #4

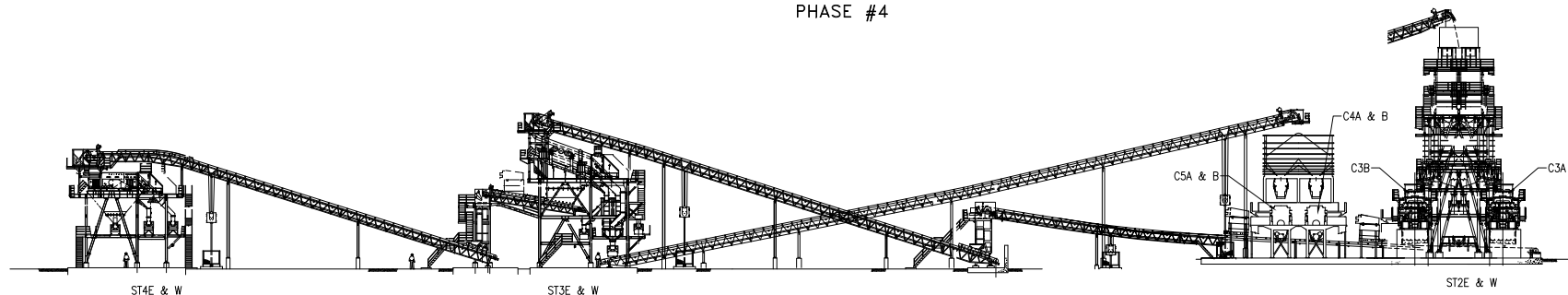

ELEVATION "B-B"  
PHASE #5

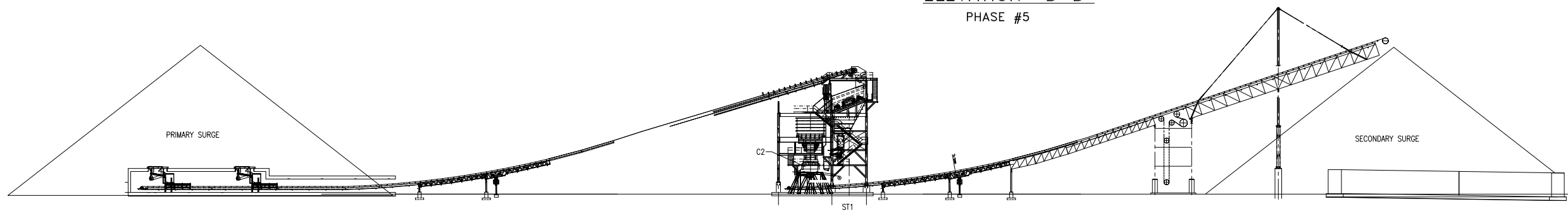

ELEVATION "A-A"

PROPOSED PLANT ELEVATIONS

PRELIMINARY ELEVATIONS TO ILLUSTRATE  
THE EQUIPMENT SHOWN ON PLANT LAYOUTS  
FIGURES 3-19 & 3-20



D			
C			
B			
A			
-	INITIAL RELEASE		
-	DATE	REVISION	BY

TOLERANCES—UNLESS NOTED  
 FRACTIONAL: ± 1/16"  
 DECIMAL: ± 0.010"  
 ANGLE: ± 0.1°  
 THIS DRAWING IN DESIGN AND DETAIL IS THE  
 PROPERTY OF VULCAN MATERIALS COMPANY  
 AND MUST BE RETURNED UPON DEMAND. THIS  
 DRAWING MUST NOT BE COPIED, REPRODUCED,  
 OR USED WITHOUT PERMISSION.



PLANT ELEVATIONS	
PHASES 4 & 5	

STATE	NOVA SCOTIA	PLANT	BLACK POINT
BY	CB	BY	LJ
DATE	8/19/14	DATE	9/15/14
DWG. NO.		SCALE	1 : 400
		SHEET	1 OF 1
		REV.	

FIGURE 3.0-21

REV

### **3.1.4 Stockpiles, Overburden and Crusher Fines**

The processing plant site is approximately 28 ha in size and occupies the northern section of the 354.5 ha Project site along Chedabucto Bay (**Figure 3.0-1**). This area will be used for processing (e.g. secondary and tertiary crushing, screening, washing and conveying), as well as stockpiling aggregate products, equipment, fuel and material storage, ship loading and administrative buildings.

The area will contain two ponds beginning in Phase 3, located on the western edge of the plant site against the cliff. Each pond will be sized to hold approximately 6,100 m<sup>3</sup>. One of the ponds will be dedicated to stormwater retention and will be dry most of the time, while the other will be used to supply process water for washing and dust control. During Phase 1, temporary ponds will be utilized as required to manage stormwater. In Phase 2, one of the permanent ponds will be constructed and dedicated to stormwater retention.

This portion of the site will include two surge piles, various aggregate product piles (fractionated, screenings and base material) and approximately 1,000,000 tons of product ready for shipment. The plant layout and water system will be designed to minimize airborne dust emissions by employing wet suppression for dust control.

Storage locations of overburden and organic materials will be selected as part of the detailed site engineering. For the purposes of the EIS, overburden storage is shown in a screening berm along the southern property boundary and in various designed piles inside the pit boundary (see **Figures 3.0-2 through 3.0-12**).

### **3.1.5 Administrative Buildings**

Approximately 2.5 ha will be dedicated for an administrative area and will be located on the eastern edge of the plant site (**Figure 3.0-18**). In this area, two buildings (modular or fixed) will be erected. One will contain offices and the administrative functions while the other will contain facilities for on-site workers such as a locker/shower room, washroom, first aid station, lunchroom, quality control laboratory and shop. This area will also include a site to store fuel and other maintenance fluids. Mobile equipment will be parked adjacent to the shop.

### **3.1.6 Transmission Line Tie In**

Electrical power will be required for buildings and the operation of equipment (pumps, conveyors, crushers, screens and ship loading). Electrical demand will vary over the life of the Project. During Phases 1 and 2, a 200 amp service will be sufficient to provide power for the buildings. Diesel powered generators will provide the power for the processing plant and equipment during this time. The 200 amp electrical service is expected to be provided from a 25 KV high voltage distribution line running along Route 16 and operated by NSPI. The line will be routed adjacent to the entrance road with a pole mounted transformer located near the temporary office as shown on **Figures 3.0-16 and 3.0-17**. Due to the line location along the disturbed portion of the entrance road, no additional environmental effects are anticipated.

Once sales demand dictates a larger plant, a tie-in will be made to the 69 KV high voltage line that runs along the southern boundary of the Project site. This line will also be routed adjacent to the entrance road and will terminate at the substation as shown on **Figure 3.0-19**. Again, the



line will be routed along the disturbed portion of the entrance road so no additional environmental effects will result. All power to the plant will be routed underground from the substation and these lines will remain within the Project property. The transformer sub-station will be required to reduce the voltage for the quarry. The peak electrical power demand for the site is estimated to be between 10,000 and 12,000 horsepower (i.e., 5.0 to 6.0 MW). Following discussions with NSPI, the tie-in to the high voltage line and the sub-station are expected to be provided and owned by NSPI. Temporary diesel powered generators may be needed until such time as the sub-station and transmission link are complete.

### **3.1.7 Marine Terminal**

Based upon preliminary engineering, a rubble mound approach (where conveyors and related infrastructure are installed on a stone breakwater constructed of coarse rock extending from the shore) will be utilized in the design of the marine terminal. Caissons and mooring dolphins will be used for berthing the ship. The rubble mound will comprise the primary structural element of the terminal and will provide stability for the shiploader during operations as well as a means of egress for maintenance. Preliminary engineering drawings for the terminal are shown in **Figure 3.0-22 through Figure 3.0-25**. The major components of the facility are:

- Three breasting caissons used for berthing the ship.
- Two mooring dolphins.
- Eleven slewing rail piers that support the slewing rail, which in turn allows the shiploader to move in an arc.
- One slewing rail caisson to support the slewing rail.
- Shiploader pivot point caisson, which provides the lateral stability of the shiploader.
- Rubble fill with an access road for maintenance.
- The shiploader arm that delivers aggregate product to the ship.

The shiploader is a telescoping system approximately 136 m long when fully extended. It is capable of loading vessels up to 70,000 deadweight tons (DWT) without warping (shifting) the vessel. The shiploader transports material from the land based conveyor into the ship and will have a loading capacity approaching 5,000 TPH. Lighting will be shielded to direct light down onto the conveyor during night operations. Navigational lighting will be provided as required by Transport Canada.

The rubble mound portion of the terminal will be approximately 160 m in length as shown in **Figure 3.0-24**. It will be constructed with a clean rock-filled base, armour stone protection on all sides and include a crushed stone surface. This structure will have a seafloor footprint of approximately 11,078 m<sup>2</sup> which includes the combined seafloor surface area occupied by the rubble fill, caissons and dolphins. The dolphins and piles will be designed and constructed to withstand the horizontal loads associated with the berthing of vessels as well as the environmental loads (wind, waves, etc.) present.

Shipping will be contracted to a third party and no waste disposal, deck washing or fuelling will occur at the marine terminal.

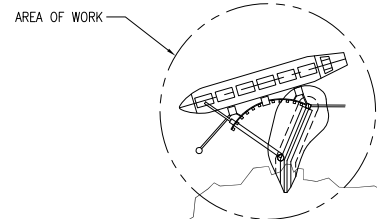

SITE LOCATION PLAN

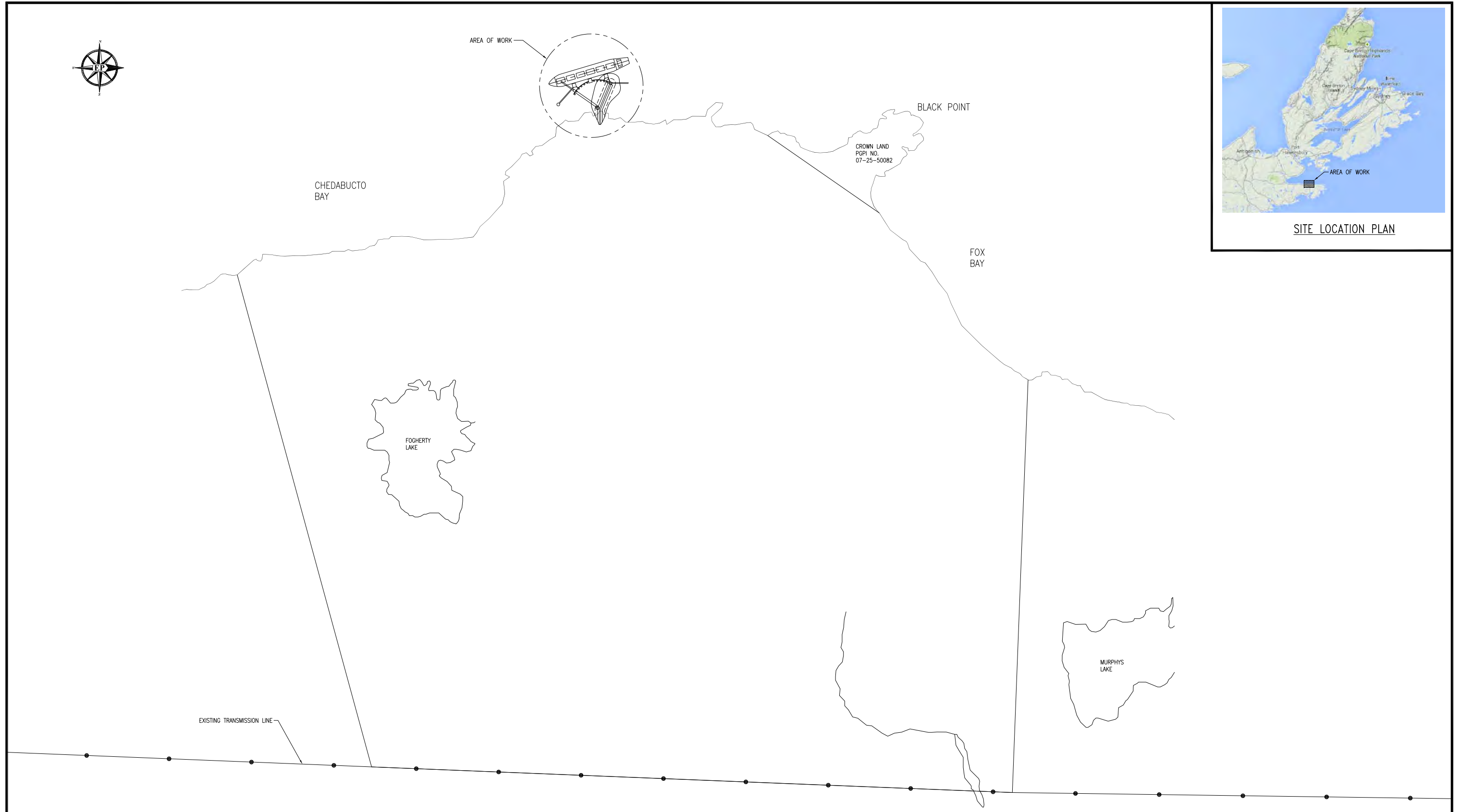

SITE LAYOUT PLAN

SCALE: 1:5000



**NOTE:**  
(LAYOUT MAY CHANGE TO SUIT FIELD CONDITIONS,  
FINAL EQUIPMENT SELECTION, ETC.)



D			
C			
B			
A	2014/08/28	ISSUED FOR PERMIT	BT
	DATE	REVISION	BY

**TOLERANCES—UNLESS NOTED**  
 FRACTIONAL: ± 1/16"  
 DECIMAL: ± 0.010"  
 ANGLE: ± 0.1°  
 THIS DRAWING IN DESIGN AND DETAIL IS THE PROPERTY OF VULCAN MATERIALS COMPANY AND MUST BE RETURNED UPON DEMAND. THIS DRAWING MUST NOT BE COPIED, REPRODUCED, OR USED WITHOUT PERMISSION.



SITE LAYOUT PLAN	
MARINE TERMINAL	
EASTPOINT DRAWING NUMBER S001	

STATE	NOVA SCOTIA	PLANT	BLACK POINT
BY	QHS	BT	PROJ. NO. 55126
DATE	2014/09/05	DATE	2014/08/28
DWG. NO.		SCALE	AS NOTED
		SHEET	1 OF 4
		REV.	A

FIGURE 3.0-22

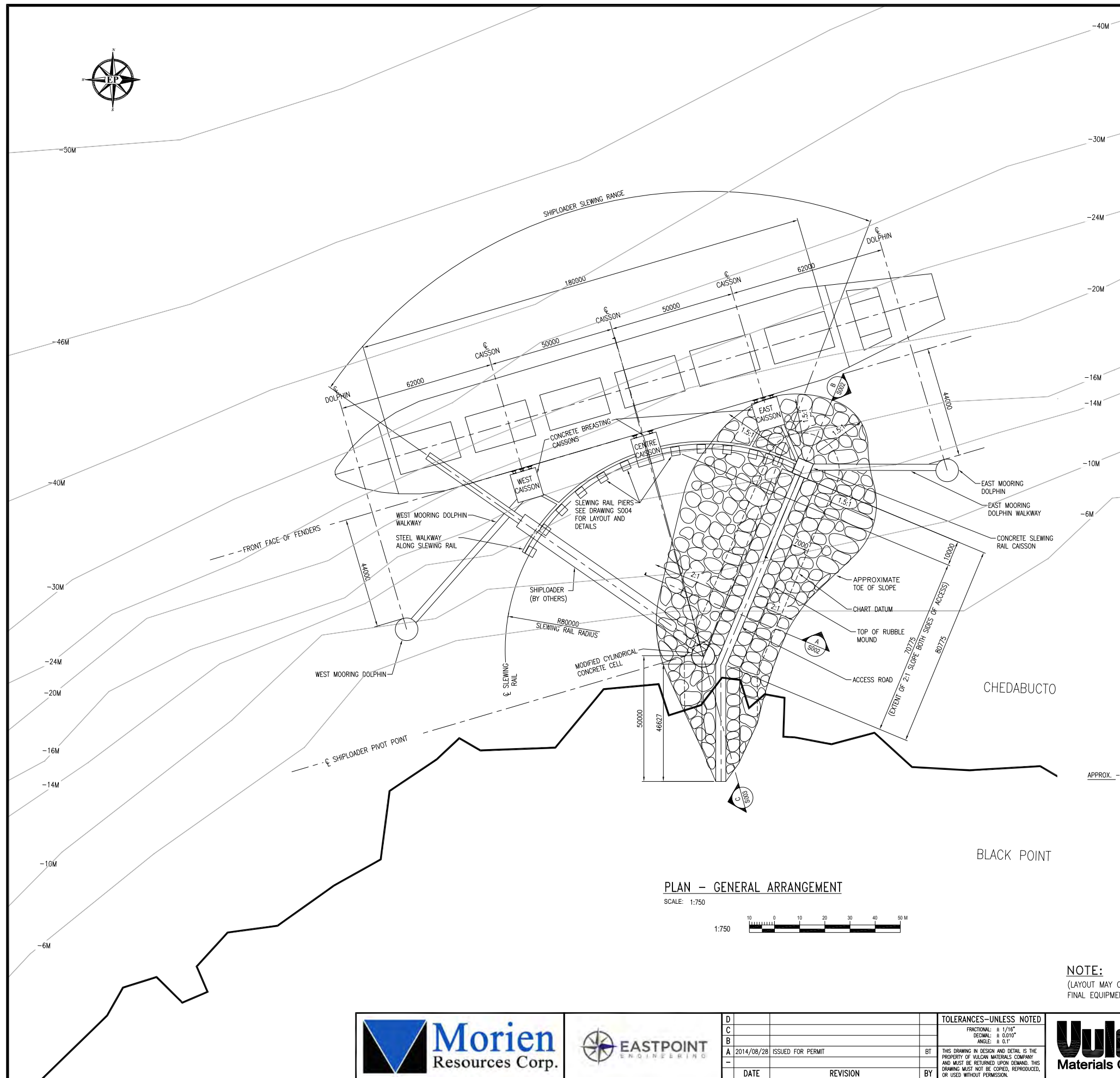

**PLAN - GENERAL ARRANGEMENT**  
SCALE: 1:750

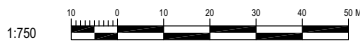

AREA OF IMPACT AT SEA FLOOR	
RUBBLE MOUND	7916M <sup>2</sup>
BREASTING CAISSONS (3)	1120M <sup>2</sup>
MOORING DOLPHIN (2)	1050M <sup>2</sup>
SLEWING RAIL AND PIER	992M <sup>2</sup>

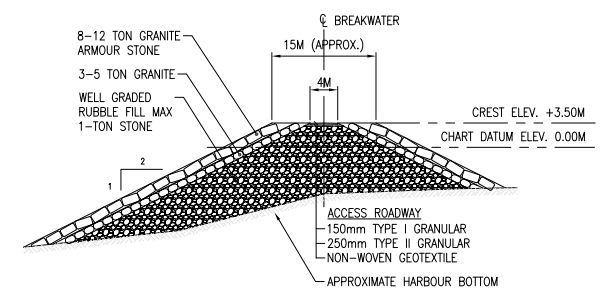

**SECTION - TYPICAL RUBBLE MOUND**  
SCALE: 1:500

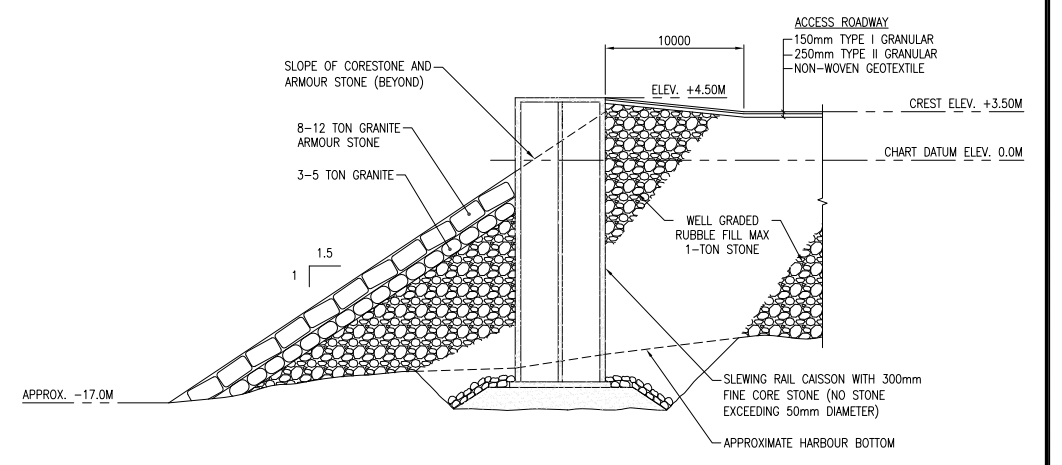

**SECTION - RUBBLE MOUND AT CAISSON**  
SCALE: 1:250



**NOTE:**  
(LAYOUT MAY CHANGE TO SUIT FIELD CONDITIONS,  
FINAL EQUIPMENT SELECTION, ETC.)



DATE	REVISION	BY
2014/08/28	ISSUED FOR PERMIT	BT

**TOLERANCES—UNLESS NOTED**  
FRACTIONAL: ± 1/16"  
DECIMAL: ± 0.010"  
ANGLE: ± 0.1°

THIS DRAWING IN DESIGN AND DETAIL IS THE PROPERTY OF VULCAN MATERIALS COMPANY AND MUST BE RETURNED UPON DEMAND. THIS DRAWING MUST NOT BE COPIED, REPRODUCED, OR USED WITHOUT PERMISSION.



GENERAL ARRANGEMENT	
EASTPOINT DRAWING NUMBER S002	

NOVA SCOTIA		BLACK POINT	
BY: QHS	BT	PROJ. NO.: 55126	FILE SERVER: EASTPOINT
DATE: 2014/09/08	DATE: 2014/08/28	SCALE: AS NOTED	SHEET 2 OF 4
FIGURE 3.0-23		REV. A	

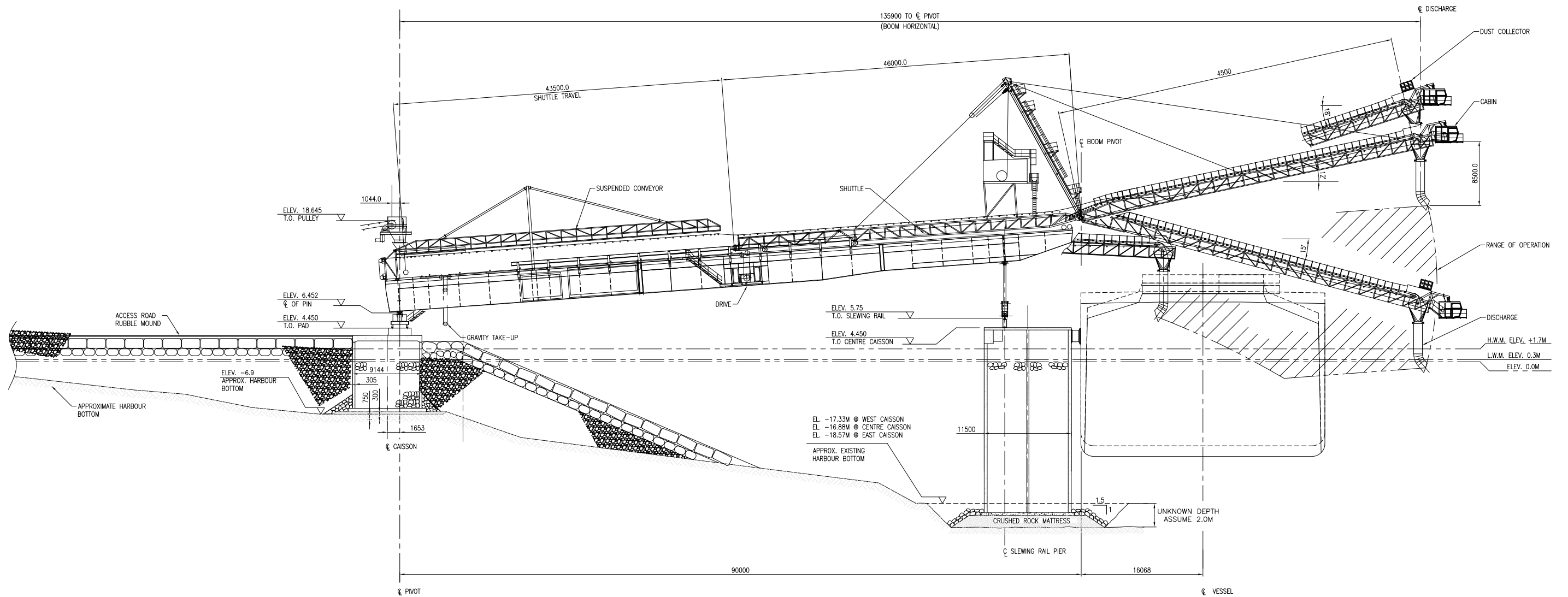

**B SECTION**  
 S002 SCALE: 1:250

**NOTE:**  
 (LAYOUT MAY CHANGE TO SUIT FIELD CONDITIONS,  
 FINAL EQUIPMENT SELECTION, ETC.)



D			
C			
B			
A	2014/08/28	ISSUED FOR PERMIT	BT
	DATE	REVISION	BY

**TOLERANCES—UNLESS NOTED**  
 FRACTIONAL: ± 1/16"  
 DECIMAL: ± 0.010"  
 ANGLE: ± 0.1°

THIS DRAWING IN DESIGN AND DETAIL IS THE PROPERTY OF VULCAN MATERIALS COMPANY AND MUST BE RETURNED UPON DEMAND. THIS DRAWING MUST NOT BE COPIED, REPRODUCED, OR USED WITHOUT PERMISSION.



SECTION VIEW

EASTPOINT DRAWING NUMBER S003

STATE	NOVA SCOTIA	PLANT	BLACK POINT
BY	QHS	BT	PROJ. NO. 55126
DATE	2014/09/05	DATE	2014/08/28
SCALE	AS NOTED	SHEET	3 OF 4
FIG. NO.	FIGURE 3.0-24		REV. A



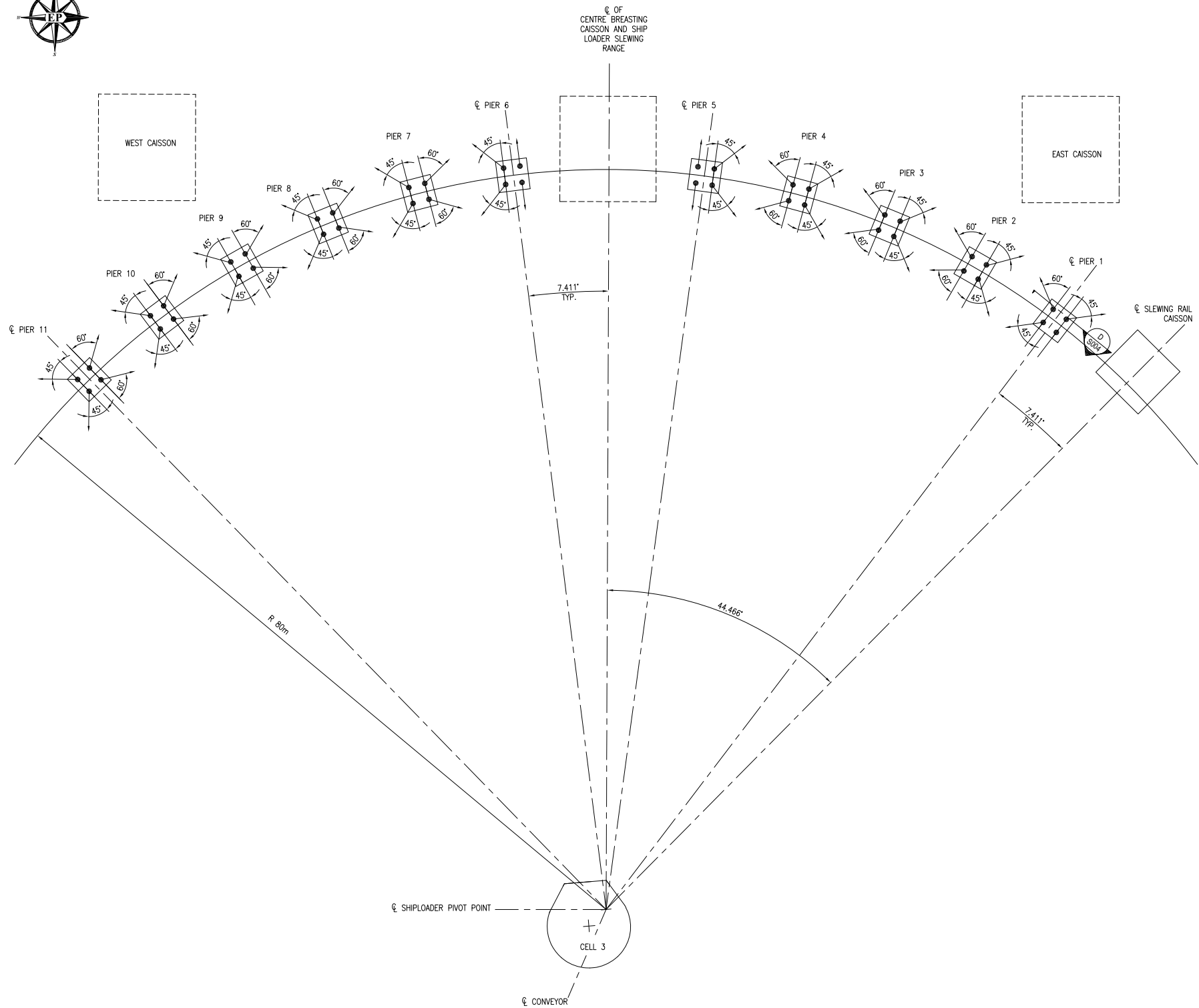

PLAN - SLEWING RAIL PIER LAYOUT

SCALE: 1:250  
 1:250

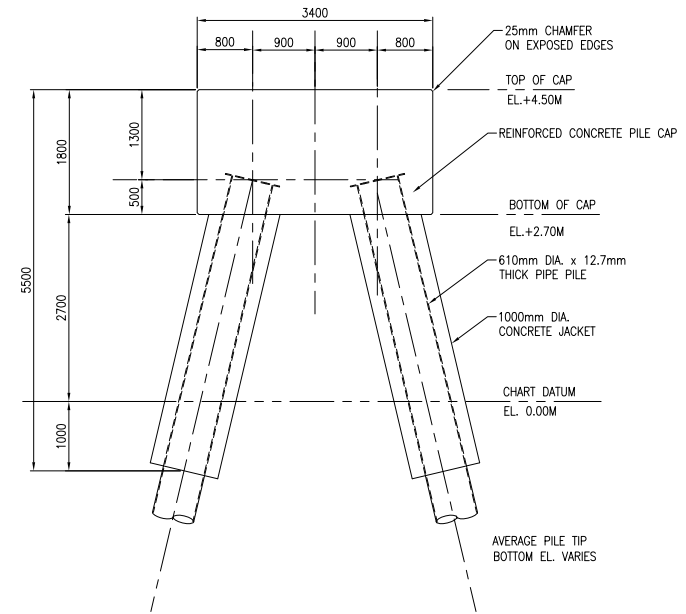

D SECTION - TYPICAL SLEWING RAIL PIER  
 S004 SCALE: 1:50

NOTE:  
 (LAYOUT MAY CHANGE TO SUIT FIELD CONDITIONS,  
 FINAL EQUIPMENT SELECTION, ETC.)



D			
C			
B			
A	2014/08/28	ISSUED FOR PERMIT	BT
	DATE	REVISION	BY

TOLERANCES—UNLESS NOTED  
 FRACTIONAL: ± 1/16"  
 DECIMAL: ± 0.010"  
 ANGLE: ± 0.1°  
 THIS DRAWING IN DESIGN AND DETAIL IS THE PROPERTY OF VULCAN MATERIALS COMPANY AND MUST BE RETURNED UPON DEMAND. THIS DRAWING MUST NOT BE COPIED, REPRODUCED, OR USED WITHOUT PERMISSION.



SLEWING RAIL PIER LAYOUT PLAN	
AND SECTION	
EASTPOINT DRAWING NUMBER S004	

STATE	NOVA SCOTIA	PLANT	BLACK POINT
BY	QHS	BT	PROJ. NO. 55126
DATE	2014/09/05	DATE	2014/08/28
SCALE	AS NOTED	SHEET	4 OF 4
FIGURE 3.0.0-25			REV. A

### **3.1.8 Waste Water Treatment System (Other Utilities)**

Other utilities will include domestic water supply that will be supplied by drilled groundwater wells, and a waste water or sewage disposal system to facilitate the needs of on-site workers (please see Section 3.3.7). Propane tanks may also be installed for heating or other functions.

## **3.2 CONSTRUCTION PHASE**

### **3.2.1 Construction Activities**

When construction begins, there will be two main activities: site preparation and plant construction (see Table 3-1). Site preparation will come first. A temporary crushing facility will be employed to produce the crushed stone needed to surface the access road and level the plant site for the site preparation. The permanent plant will be constructed as soon as sales warrant. Site preparation and construction activities are described below.

#### *Site Preparation*

- Vegetation removal and stockpiling<sup>2</sup>;
- Entrance and infrastructure road clearing and initial construction;
- Erection of the temporary crushing facility;
- Surveying and delineating plant site, road right of ways, and protected areas buffers;
- Blasting and rock crushing to produce surfacing stone for roads and the Plant site;
- Plant site grading to create suitable plant/laydown area with controlled drainage;
- Erosion and sedimentation control installation, including stormwater management pond(s);
- Site access control including gates, and earthen and boulder berms; and
- Excavation of sanitary and process waste collection disposal system

#### *Construction*

- Employ a modular portable plant to process stone during early phases;
- Undertake blasting and crushing to produce additional surfacing stone;
- Create trenches for electrical conduits;
- Construct concrete foundations for processing plant equipment;
- Install an electrical substation and supporting power network;

---

<sup>2</sup> Vegetation removal will be undertaken on an as needed basis, rather than over the entire site at project start up. Vegetation removal will occur outside of the breeding bird season.

- Build temporary and permanent office locations;
- Pour concrete pad and containment area for petroleum products; and
- Excavate additional stormwater management pond(s)

### *Best Management Practices*

Guidelines for construction and site grading have been created by the Province and will be employed.

- Sedimentation and Erosion Control Handbook (NSE 1988);
- Watercourse Alteration Protection; Erosion Protection; Wharves (NSE 2013b); and
- Nova Scotia Pit and Quarry Guidelines (NSEL 1999)

### **3.2.2 Geotechnical Investigations and ARD**

The bedrock geology of the Black Point area is outlined in Section 6.1.3 of this report and in a Geological Survey of Canada report and accompanying map (Hill 1991). The proposed pit area is underlain by homogeneous biotite-muscovite granite. Analysis of this granite from a suite of samples collected from 10 drill holes distributed throughout the proposed quarry indicated very low concentrations of total sulphur (<0.01%) and these rocks are therefore considered to have non-existent potential for generating Acid Rock Drainage / Metal Leaching (ARD/ML).

In contrast, the processing plant area (the lower platform) is underlain by two rock formations: the Halifax Formation, which forms a wedge-shaped block adjacent to the prominent granite hill where the quarry will be developed, and the Goldenville Formation along the coast from Black Point to Fogarty Head. Since these rocks are known to be potentially acid generating elsewhere in Nova Scotia, the Proponent's geological staff conducted a geological mapping and sampling program in 2011 and submitted a suite of 6 representative samples of bedrock for geochemical and ARD/ML analysis (Dalton 2011). Of the 6 samples collected, only 1 sample contained significant concentrations of sulphide minerals (1.0% total sulphur) and had potential for generating ARD/ML (acid producing potential; kg/t H<sub>2</sub>SO<sub>4</sub> = 28.60), although the pH of this sample was slightly alkaline (7.4 pH) suggesting the presence of carbonate minerals that have pH buffering capacity. The remaining 5 samples from the Halifax and Goldenville Formations had low sulphur concentrations (<0.19%) and have very low potential to generate ARD/ML (acid producing potential; kg/t H<sub>2</sub>SO<sub>4</sub> = 0.11 – 0.43) if exposed during construction.

The site for the processing plant will be developed over Halifax and Goldenville Formation rocks to a mean height above sea level of 22 m. An assessment of the topography at the site indicates that this development will involve both the excavation of a central 11.8 hectare area of Halifax Formation rocks and the in-filling of three separate low-lying areas (1.5, 1.3 and 6.1 hectares; **Figures 3.0-26 & 3.0-27**). The first phase of development for the processing plant area will involve clearing the site of vegetation and grubbing the topsoil to expose bedrock. At that time it will be possible to assess the presence and extent of potential acid generating (PAG) rocks of the Halifax Formation by following the sampling and analysis protocols outlined in the 2009 Mine Environment Neutral Drainage (MEND) Program report entitled *Prediction Manual for Drainage Chemistry from Sulphidic Geologic Materials* and the 1995 provincial *Sulphide Bearing*

*Material Disposal Regulations.* Two representative samples will be collected from each hectare of probable Halifax Formation rocks and these will be submitted for analysis, using procedures in accordance with above regulations and guidelines, to determine if ARD/ML issues are present.

As noted above, the entire processing plant site will be graded and sloped such that all rainfall and drainage will migrate to the south side of the site where it will be collected in ponds. In addition, a 1 m high berm will surround the entire plant site to ensure all surface water is captured. These features will ensure that no acidic drainage will be discharged to Chedabucto Bay.

There are no freshwater streams with fish habitat in the area to be excavated to create the processing plant area, nor are there streams or freshwater fish habitat within 60 m of the site.

If ARD/ML is present, based on the testing of the material from the processing plant site, then this matter will be addressed in accordance with the 1995 *Sulphide Bearing Material Disposal Regulations*, and any appropriate protocols outlined in the 2009 Mine Environment Neutral Drainage (MEND) Program manual for handling sulphide-bearing materials. In addition, long term kinetic testing of PAG or Uncertain PAG material (excavated or disturbed) will be undertaken if needed to evaluate rates of acid generation and neutralization, potential time to onset of acid generation, and drainage chemistry and contaminant loadings in and around the plant site.

### **3.2.3 Site Preparation, Cut and Fill, Blasting**

The site preparation and construction phase of the Project will begin with clearing of vegetation and removal of organic material and overburden for the development of the 28 ha plant site and administrative area. This area will require cut and fill activities and will be conducted as described in Section 3.2.2.

Preliminary mass balance calculations for the plant and administrative areas suggests a cut or excavation of approximately 600,000 m<sup>3</sup> and a fill of 835,000 m<sup>3</sup> will be needed to level the area prior to construction (**Figures 3.0-26 and 3.0-27**). The swell factor (i.e., the increase in volume that occurs when solid rock is broken up and excavated) has been estimated at approximately 40%. Additionally, the plant and administrative area will be designed with 1% of cross slope drainage which will direct all storm water to the two ponds described in Sections 3.1.4, and 3.3.7. Any additional required fill material will be generated using the initial mobile processing plant. The final elevation of the plant area and administrative areas will be approximately 22 masl. The site preparation and construction phase of the plant site and administrative area is anticipated to occur over a 36 month period.

As mining activities begin, vegetation and the removal of organic material and overburden will be conducted to establish a rock face at the north end of the property. A phased mining approach will be used to minimize impacts and to allow natural vegetation to remain as long as possible. With the exception of organics, materials extracted during these early development stages will primarily be used for construction of access roads, the laydown areas, and the fill for the marine terminal. Topsoil and excess overburden, if any is encountered, and crusher fines will be stockpiled (separately) and stabilized (e.g., seeded) for future use in the reclamation phase. Much of the overburden will be stored in berms on the edges of the property, thereby increasing sound and visual buffers.



To minimize the potential for erosion and sedimentation, clearing, grubbing and removal of overburden will be conducted in a progressive manner to accommodate drilling and blasting activities, such that the amount of exposed erodible soils is minimized. Clearing activities will take place outside of the breeding season for most bird species (April to September 1) to prevent the disturbance of migratory birds or their nests. If some clearing is necessary during the breeding season, the feasibility of maintaining compliance with the *Migratory Birds Convention Act* will be assessed and a contingency plan developed in consultation with CWS to ensure compliance with *Migratory Birds Convention Act* .during clearing.



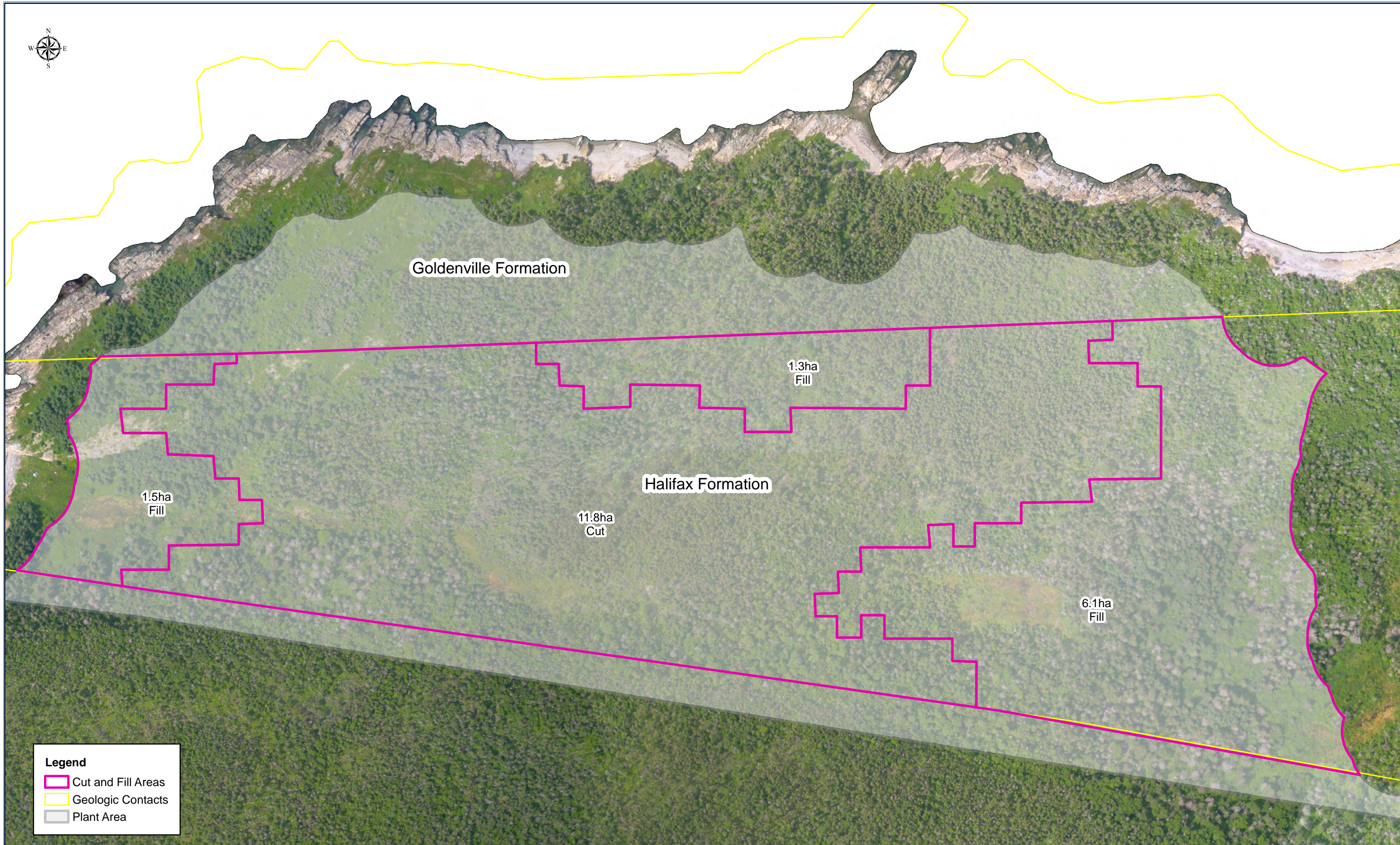

Goldenville Formation

1.3ha  
Fill

Halifax Formation

1.5ha  
Fill

11.8ha  
Cut

6.1ha  
Fill

**Legend**

- Cut and Fill Areas
- Geologic Contacts
- Plant Area



THIS DRAWING IN DESIGN AND DETAIL IS THE PROPERTY OF VULCAN MATERIALS COMPANY AND MUST BE RETURNED UPON DEMAND. THIS DRAWING MUST NOT BE COPIED, REPRODUCED, OR USED WITHOUT PERMISSION.



Cut and Fill Areas

REGION	NOVA SCOTIA	PLANT	BLACK POINT
DRAWN BY	CKR	DATE	10/22/2014
CHECKED BY		SCALE	1 in = 60 m
JOB NO.		DWG. NO.	Figure 3.0-26
PATH			

PLOTTED: LAST UPDATE:

DATE	REVISION	BY	ISSUE DATE



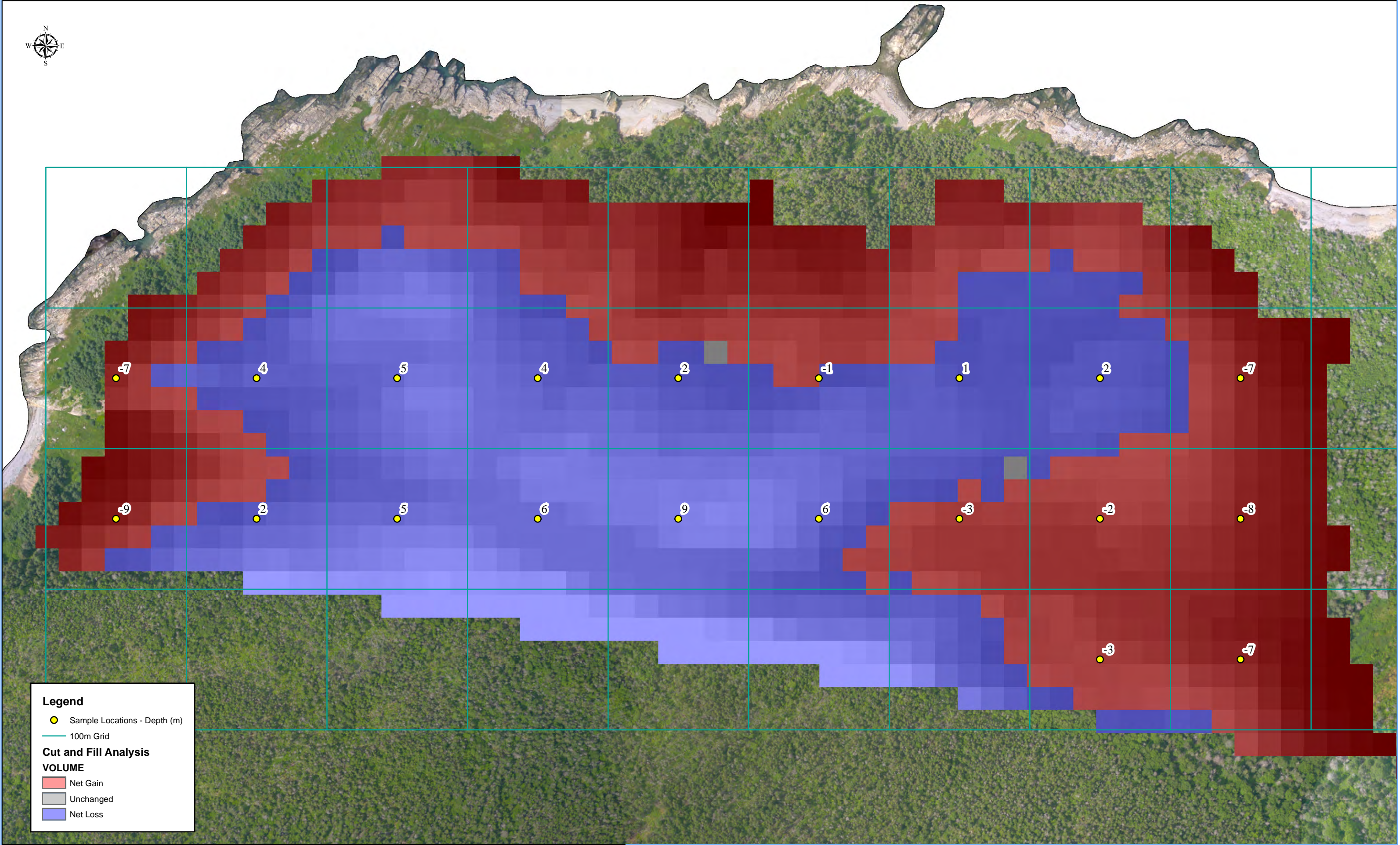

**Legend**

- Sample Locations - Depth (m)
- 100m Grid

**Cut and Fill Analysis**

**VOLUME**

- Net Gain
- Unchanged
- Net Loss



PLOTTED: LAST UPDATE:



DATE	REVISION	BY	ISSUE DATE:

THIS DRAWING IN DESIGN AND DETAIL IS THE PROPERTY OF VULCAN MATERIALS COMPANY AND MUST BE RETURNED UPON DEMAND. THIS DRAWING MUST NOT BE COPIED, REPRODUCED, OR USED WITHOUT PERMISSION.



Cut and Fill Sample Locations

REGION	NOVA SCOTIA	PLANT	BLACK POINT
OWN BY	CKR	DATE	10/22/2014
CHK BY		SCALE	1 in = 60 m
JOB NO.		DWG. NO.	Figure 3.0-27
PATH			



### **3.2.4 Access Road and Transmission Tie-in**

Access to the Project site will be made utilizing a new access road that will connect Route 16 to the plant site adjacent to Chedabucto Bay as shown on **Figure 3.0-1**. A majority of the materials necessary for the construction of the road will be extracted from the quarry site. The intersection at Route 16 and a portion of the access road will be paved to minimize dust and track-out issues on Route 16. The intersection will be designed to meet provincial highway department standards.

To the extent possible, the access road will be located so as to avoid watercourse crossings. Where this is not possible, a culvert will be installed. Installation of these structures may require a Water Approval pursuant to the provincial *Activities Designation Regulations* and will be installed between June 1<sup>st</sup> and September 30<sup>th</sup>, unless otherwise authorized. Structures will be designed to accommodate the 100 year storm.

Gradients on the access road will not exceed 10%. Similarly constructed gravel access roads within the quarry will be built to connect the land based infrastructure and the ship loading facility. All necessary erosion and sediment controls such as silt fences, temporary sedimentation ponds, and/or rip rap check dams will be installed as required during construction of the road.

During Phases 1 and 2 of the Project, either an electrical service provided by NSPI from the transmission line running adjacent to Route 16 or a diesel powered generator will be required. If necessary, the new service would access the site via the newly constructed access road. All required clearing and grubbing would be completed by the Proponent based upon NSPI requirements. As the sales demand increases, a new service will be required to provide power for the fixed plant. This is expected to be provided by NSPI from the high voltage line running along the southern boundary of the project site. All lines as well as the sub-station are expected to be installed and owned by NSPI.

### **3.2.5 Processing Plant and Laydown Areas**

After the plant site is developed in the early phases of the project and the sales demand has increased to an appropriate level, a large fixed plant will be built. The construction period for the fixed plant will span approximately 18 months dependent upon weather. A majority of the materials necessary for construction will be extracted from the quarry site. This will involve some blasting, heavy excavation equipment, crushing and screening. Depending on the availability of concrete from nearby sources, a small concrete batch plant may be established on-site during the construction period. After site preparation, the activities will shift to installation of foundations.

Prefabrication activities will proceed off site in parallel with civil works, so that as foundations are completed phased delivery of prefabricated structures, equipment skids, subassemblies, and modules can progress. Work associated with electrical and piping needs follow once the structures are erected. Deliveries will be sequenced to support the installation, hook-up, and commissioning program. A majority of the steel structures and equipment will be shipped to the local port and trucked to the site for erection. Several mobile cranes will be utilized on-site during the construction phase.



Construction will be work packaged from the outset so that the integrity of the structures and equipment can be better managed. Construction sequencing will be strongly focused on the testing and commissioning program that brings the plant into operation on schedule. Appropriate dust and drainage control based on the avoidance of environmentally sensitive areas will be applied throughout.

A second construction phase will follow in future years as the sales demand increases. This phase will involve the construction of a second tertiary plant in parallel with the existing one. This work should be completed within approximately six months and will include similar steps as those outlined above with the exception of blasting.

### **3.2.6 Marine Terminal**

The preferred construction approach for the marine terminal employs a fill and rock technique that results in a relatively large footprint on the seabed. A current estimate of the impact totals 11,078 m<sup>2</sup>. Preliminary engineering drawings for the terminal are shown in **Figure 3.0-22 through Figure 3.0-25**. Additional geotechnical work will be required before the drawings are finalized. To accomplish this, a marine engineering firm will be contracted to complete borings of the seabed. This will allow the exact depth, location and integrity of the seabed to be verified.

The terminal will be constructed along the shore using fill and rock (i.e. rip-rap) material sourced from the site. At this time, blasting in the terrestrial near shore area does not appear to be required for construction of the laydown area and approach to the wharf.

The major components of the facility and the expected construction duration of each component are shown below with the total project duration expected to be between 11 and 13 months.

<u>Component</u>	<u>Duration (Sequential)</u>
Caissons	Four Months
Piers/Dolphins	Four to Six Months
Rubble Approach	Two Months
Slewing Rail and Shiploader	One Month

It is expected that slip forming (construction in place) of each caisson will take approximately one week. Installation will be a 24 hour operation until the caisson is cast to about half way between low and high tides. Typical activities include cranes to lift in reinforcing steel, concrete trucks and pumps and lights for night time activity. The completion of each caisson, once sunk, will take approximately one month. The slewing rail piers will be supported by piles which will be installed from a barge. There will be approximately eleven piers which are expected to have four piles each. The piles will be installed using pile driving hammers and churn drills and will be anchored in the bedrock. Silt curtains and acoustic blankets will be considered during installation, as needed. All marine construction will be completed using conventional marine construction techniques.

Prefabricated steel for the slewing rail and the shiploader will be delivered to the site via barge. Installation will be conducted utilizing cranes and work barges. The loadout conveyor (equipped with aggregate spill containment) will extend from the onshore loadout system to the shiploader.

Any piles required for the loadout conveyor in the nearshore area would be located in the rubble fill.

### **3.2.7 Construction Water Use and Water Management**

The construction activities will require water primarily for site dust control. The water will be applied to the areas of the property where earthwork is occurring and to the plant haul roads to control fugitive dust emissions. The portable processing plant will also use water to control dust emissions from the initial crushing operations.

The water volumes used during the construction phase will be minimal compared to the amounts that will be needed when the quarry pit is more fully developed and the permanent processing plant is operational. The water source during construction will be runoff from precipitation captured in retention basins and pit sump. These basins and the sump will be installed early in the construction phase to control sediment runoff and to provide a water supply. In the event that sufficient water is not available at the beginning of construction then water will be procured from off-site sources. Drilled wells will also be considered as an alternative.

Wastewater generated from the construction activities will primarily be runoff from precipitation that falls on the areas disturbed during the construction (i.e., stormwater runoff). Sediment and erosion control measures including site contouring to direct runoff to the retention basins and silt fences, aggregate rock filters, and other best management practices will be employed as needed. These measures will be described in a site-specific Erosion and Sediment Control Plan.

### **3.2.8 Construction Related Noise**

The site development and initial rock processing that will occur during the construction phase will involve activities similar to those that will occur during full facility operation. The equipment used for construction will be similar to the equipment that will be part of the site operation. Noise generated from construction is anticipated to be similar to the noise that will be generated from facility operations. Construction related noise and vibrations will be controlled primarily through attenuation (distance between the source and receptor). The noise levels from the construction activities will comply with the Pit and Quarry Guidelines established for operational sound levels (NSEL 1999). The construction sound levels will be maintained to not exceed the following levels at the boundaries of the Project site:

- 65 dBA 0700 – 1900 hours (Days);
- 60 dBA 1900 – 2300 hours (Evenings); and
- 55 dBA 2300 – 0700 hours (Nights, Sunday and statutory holidays).

Please refer to Sections 6.3 and 7.2 for additional information regarding noise.

### **3.2.9 Construction Related Traffic**

The Black Point Project construction activities will occur within the boundaries of the Project area and will not have a significant effect on public highway traffic. The movement of equipment to the site will occur sporadically during normal working hours. The construction of the site

access road will be done in a manner that minimizes any impact to traffic on the public highway. There will be an increase in vehicles accessing the site during the peak of site construction activity and during worker shift changes. Areas within the facility boundary will be established for parking of construction employee vehicles to prevent any traffic issues associated with parking along the public highway.

Any oversize equipment delivered to the site will be done in compliance with provincial transportation requirements and if necessary protective measures such as flagmen or accompaniment by caution vehicles or police agencies will be followed.

### **3.2.10 Construction Schedule**

A preliminary construction schedule is provided as Table 3-1. It should be noted that the schedule will be dependent on approvals, final designs, and the procurement of equipment. It is anticipated that the construction associated with site development will take approximately 2 years.

As stated previously, the site preparation and construction phase of the project will begin with the clearing of vegetation and removal of organic material and overburden for the development of the plant site. It is anticipated that these initial activities would begin early in the year. To the extent possible, clearing activities will take place outside of the breeding season for most bird species to prevent the disturbance of migratory birds or their nests. Once the site is cleared, the Phase 1 portable plant will be installed and will be utilized to produce crushed stone for rough grading. The total time needed to erect the Phase 1 plant is anticipated to be one week. As outlined in Table 3-1, the Phase 2 portable plant is expected to be added during the second year of operation. It is anticipated that this plant would be added early in the year and will be used to make a smaller diameter crushed stone used to “fine grade” the site. This plant can also be erected in approximately one week. Construction of the marine terminal should start at this time with construction expected to last approximately one year.

Once the site is complete, additional components will be added to the portable plant to produce saleable products. This addition will also have a short construction window due to the portable and modular nature of the components.

As sales demand increases, the Phase 4 plant will be constructed. It is anticipated that construction will start early in the year (Feb/Mar timeframe) with all construction completed by late fall of the same year. The final phase plant will have a construction window identical to the Phase 4 plant.

## **3.3 OPERATIONS PHASE**

### **3.3.1 Quarry Operation**

Please see Table 3-1 for construction to operation schedule. Quarry operations will gradually begin after site construction. Rock processing will generate aggregate and other construction materials for grading the plant area, making concrete for equipment foundations and creating the large stone blocks needed for the marine terminal rubble mound.

Following vegetation removal, drilling and blasting will be employed to loosen the granite in the ground. The blast-generated “shot rock” will be picked up by loaders and excavators and transported by off-road haul truck to the crushing plant (either temporary or permanent). Loading and hauling would occur up to 16 hours a day.



Other quarry equipment includes a rockbreaker (a jack hammer mounted on the end of an excavator), a grader for road maintenance and a water truck fitted with a water sprayer used to suppress dust on the roads and on the muck pile.

Blasting will be handled by a licensed and insured contractor, be performed during the hours of 8 AM to 6 PM, and will not occur on statutory holidays or Sundays. The blasting operator will be responsible for blast designs and methods in accordance with the *Blasting Safety Regulations* made pursuant to the Nova Scotia *Occupational Health and Safety Act*, the Guidelines for the Use of Explosives in or Near Canadian Fisheries Waters (Wright and Hopky 1998), and in accordance with the Nova Scotia Pit and Quarry Guidelines (NSEL 1999).

Blasting is expected to occur 1 to 3 times per month for the first two to three years and increase to 10 to 15 times per month at full operation (up to 120 times per year). Blast locations and depths will be based on pit geometry. The number of drill holes in each blast will vary depending on the purpose and bench geometry. A typical production shot will have less than 100 drill holes each drilled approximately 15 to 17 m deep. Shots utilized for quarry development such as haul roads and sumps will have variable depths generally from 3 to 10 meters. Table 3-2 presents typical blasting parameters. Upon request, residents will be alerted to upcoming production shots via automated telephone notifications ("robo-calls").

Production holes will be in a staggered or square pattern and placed in no more than four rows and will be spaced approximately 3 to 5 meters apart. Typical charge weights per hole will range from 25 kg during construction to 400 kg during normal operations. The explosive charge will consist of ammonium nitrate and fuel oil (ANFO) and an appropriate concentration of waterproof emulsion. All blasting will be conducted by a third party vendor who is licensed and insured. Blasting materials will not be manufactured or stored on site.

Benches will generally be 15 meters in height, although during the initial development phases, face heights could be less. Safety benches will be established every two benches and will have a width of approximately 7.5 meters. The final slopes for the quarry will have face angles of 85 degrees with a maximum pit slope of 65 degrees. Working benches will have face angles of 70 to 75 degrees.

Haul roads within the pit will be constructed for the movement of personnel, equipment, and materials within the quarry. Haul roads will be 30 m wide and will have a maximum grade of 10%. Sump ramps will be 20 m wide with a maximum grade of 15%.

**Table 3.1:  
 Construction to Operation Schedule**

Activity	Anticipated Commencement	Anticipated Completion
EA Approval	Q4 2014	Q4 2015
<b>Mining</b>		
Establish Access Road	2018	2018
Site Preparation	2018	2020
Establish Haul Road to Plant	2020	2020
Primary Crusher Location Established	2021	2022
Temporary Pit Sump Developed	2022	2022
Permanent Pit Sump Developed	2022	2025
<b>Plant</b>		
Portable Plant		
Phase 1	2018	2019
Phase 2	2019	2020
Phase 3	2020	2022
Permanent Plant		
Phase 4	2021	2026
Phase 5	2026	2030
<b>Marine Terminal</b>		
	2018	2020
<b>Water Management</b>		
Best Management Practices	2018	2070+
Temporary Plant Pond	2018	2018
Plant Pond 1	2018	2018
Plant Pond 2	2018	2019

**Table 3.2:  
 Standard Shot Design**

	BLASTHOLE >250 m From Water	BLASTHOLE 150-250 m from Water	BLASTHOLE 75-150 m to water	UNITS
Hole Diameter	150 (6.0")	100 (4.0")	100 (4.0")	mm
Depth	12.2	12.2	2.2	m
Burden	4	4	4	m
Spacing	4	4	4	m
<b>EXPLOSIVE TYPE AND IN HOLE DISTRIBUTION</b>				
Column Charge Type	ANFO/Emulsion	ANFO/Emulsion	ANFO/Emulsion	
Product Density	1.2	1.2	1.2	g/cc
Product per meter	21.86	9.72	9.72	kg
Product per hole	266.7	118.6	21.38	kg
<b>SHOT LAYOUT</b>				
Max No. of Holes	100	100	Variable	
Shot Patterns	Staggered or Square	Staggered or Square	Staggered or Square	
Distance to nearest non- company structure	>925	>925	>2,260	m
Distance to water	>250	>150	>75	m

**Legend**

Definitions:

Burden: The distance from the borehole and the nearest free face or the distances between the boreholes measured perpendicular to the spacing

Spacing: The distance between boreholes. In bench blasting, the distance is measured parallel to the free face and perpendicular to the burden.



### **3.3.2 Processing Plant Operation**

The type of processing plants at Black Point will vary from a small portable plant to a large fixed plant but the operations for each will be similar. Since the larger plant has a potentially greater impact, it is discussed in this section.

Blasted rock will be loaded by front-end loaders or hydraulic shovels into appropriately sized haul trucks to transport the blasted rock to the primary crusher located within or just outside the quarry boundary. This material will be dumped into the primary dump hopper where it will be fed into the primary crusher(s).

After being reduced in size at the primary crusher, the rock will be transported via conveyor to a primary surge pile located near the secondary circuit of the plant. Material will then be reclaimed (transported) from the surge pile utilizing a tunnel and conveyor and sent to the scalping screen and secondary crusher where it will be further sized and reduced. A base material (-1 ½") will be removed from the scalping screen and stockpiled by conveyor. The discharge of the screen and secondary crusher will be conveyed to a secondary surge pile.

The material in the secondary surge pile will be reclaimed by conveyor and fed into the tertiary portion of the plant. This material is routed through the remainder of the crushing and screening plant via conveyors to produce stockpiles of graded material. All stockpiles will be located over blending reclaim tunnels.

Material can be fed directly from the blending tunnels to the rinse screen(s) or a bypass conveyor around the screen(s) in various proportions to meet individual product specifications. This product will be stockpiled over tunnels that will feed the ship loadout system. The slurry generated on the rinse screen(s) will be piped to the sand screws with the overflow pumped to a clarifier and fines recovery system. The water will be reclaimed for future use.

Processing aggregate will require the operation of a variety of equipment including primary crushers (jaw or gyratory), surge piles, screens, cone crushers, reclaim tunnels, conveyors, waterlines and pumps, water clarification tank, generators and other associated mining equipment. This plant will be operated by electricity, but the portable plant may be powered by generators. Mobile equipment will likely include excavators, loaders, off-road trucks, bulldozers, water trucks, cranes, drill rigs, service vehicles, work boat, rock breaker, and barge.

Conveyors will be inter-locked and equipped with motion sensors that will stop the conveyance of material should there be an overload situation, thus preventing spillage. Routine inspection and maintenance will be conducted on all equipment.

### **3.3.3 Operational Water Requirements**

The operational water requirements for the processing plant will vary from approximately 8.8 L/s in Phase 1 to approximately 44.7 L/s in Phase 5. During the first two phases of the project as outlined in Section 3.1.3, the only water needs will be for dust suppression, base material moisture addition and potable water. It is expected that surface water accumulating in one of the two the settling ponds will satisfy the dust suppression and base moisture addition needs. Potable water needs will be met either through the purchase of water from off-site sources or by drilling a well.

During Phase 3 of the project, additional modules will be added to the portable plant to produce saleable aggregate products. One of the modules added will be a wash plant. The wash water system will be operated as a closed loop system which recycles as much of the water as possible. This plant will have two ponds: one will collect surface water for use at the processing plant and for dust control while the other will be kept dry and used to manage and treat stormwater collected on the lower platform. Each of the two ponds is designed to allow fine sediment to settle out over their length so that the water can be reused, or if excess volume is present, discharged to the ocean. A long-armed backhoe will be utilized to remove accumulated sediment from the ponds.

In the last two phases of the project a large fixed plant will be installed. The plant will continue to have a wash water system that will be operated as a closed loop system. The slurry discharge from the wash screen(s) will be piped to a sand screw(s) to recapture the coarse fines. The overflow from the sand screw(s) will be collected and pumped to a fines collection system that will have a clarification system as well as a system to extract fines. Clean water will be returned to the pond for reuse. The fixed plant will also have other needs for this clean water such as wash down stations and sprinkler heads for area dust suppression. An instantaneous water demand of approximately 708 gallons per minute (44.7 L/s) is estimated at peak production with a majority of the water recovered from the site.

### **3.3.4 Offloading to Ships**

The shiploader will load aggregate into the holds of ships (up to 70,000 tonnes) and possibly barges that will transport the material to the end markets. Aggregate loading onto the ships will approach 5,000 TPH once the full load-out system is completed. It is estimated that it will take approximately 18 to 24 hours to load the largest ships and that approximately 90-100 ships will be loaded per year once the plant reaches peak production.

Aggregate products will be the only material loaded at the Project site.

### **3.3.5 Liquid Fuel Delivery and Storage**

The Black Point operation will use diesel fuel in mobile equipment throughout the life of the facility, and to power on-site generators and portable plant equipment that will be used in the initial phase of the operation. The operation will also use other liquid petroleum and non-petroleum (antifreeze) products for equipment maintenance.

The delivery of these materials to the site will be by truck from the material suppliers who routinely handle these materials. The transfer of these materials into storage tanks at the facility will be attended by the delivery driver so that any equipment or other issues that could result in a spill are identified promptly and corrected before a spill incident occurs. The diesel fuel and other liquid petroleum products will be stored on-site in above ground storage containers in proximity to the shop. At this time, it is expected that fuel storage requirements will be met with one to two diesel storage tanks each sized at 20,000 gallons (75,708 L) or less, and one 5,000 gallon (18,297 L) gasoline reservoir. Various lube oils and other maintenance related fluids will be stored in 55 gallons (205 L) or smaller drums and a series of 4 to 8 tanks with capacity of less than 1,000 gallons (3,885 L) each.

All storage tanks will be either double walled self-contained tanks or single walled tanks with secondary containment. All petroleum storage containers 205 L (55 gallons) or larger will be stored within a contained area. These materials will be stored and handled in accordance with

all relevant regulations. The fuelling area will be erected on a reinforced concrete slab or lined containment area enclosed within side curbs and with a sloping floor to contain any spills and/or leaks that may occur during fuelling.

### **3.3.6 Hazardous Materials Management**

The hazardous materials associated with the facility will include blasting agents, waste petroleum products, and waste materials including batteries, spent parts washer fluids, used oil and anti-freeze. No pesticides or herbicides will be used on site. All of the materials stored on site will be managed to prevent spills or other releases that could impact the environment or contaminate surface water runoff. The materials will be stored in tanks and or containers in dedicated, contained areas to prevent any spills from reaching the outside environment. Hazardous materials will be handled and stored in accordance with provincial hazardous materials regulations and will be transported for off-site disposal using a licensed hazardous waste transport company. Employees will be trained on proper handling and management practices for these materials.

### **3.3.7 Wastewater Management**

#### Septic Wastewater

The Project will generate sewage and greywater waste, which will require treatment either on site using a standard wastewater treatment system, or offsite at a municipal wastewater treatment facility. It is expected that during the construction and early operations phases of the project, portable sanitation units will be utilized. A permanent washroom and bathing facility may be constructed at a later date as the project advances through the operations phase.

The Project site will not have a conventional septic tank and soil absorption disposal field due to the shallow soil overlying the bedrock, which will not permit adequate treatment of the wastewater. As an alternative, it is anticipated that a large volume holding tank will be utilized during the construction phase of the project. The sewage and greywater waste would be directed to the holding tank and pumped out by truck to be hauled by a licensed septic waste transport company for offsite treatment. It is anticipated that holding tanks totalling 227 m<sup>3</sup> will be sufficient to collect the waste from 60 workers for two weeks, after which the tanks would be emptied and the waste transported for offsite treatment (NLDEC 2005). This volume provides for 1.5 times the maximum daily flow for two weeks<sup>3</sup>.

A conventional raised bed septic system (where the treatment medium, typically sand, is imported onto the site) will also be considered as a possible alternative on-site treatment method. The type of raised bed system suitable for the project site would be determined at a later date following the completion of test pits that would provide technical information about the soil profile at the proposed system location. In both cases, the magnitude of waste generated will be proportional to the number of workers employed at the project site. The volume of the holding tank or size of the raised bed septic system will be based on peak employment estimates.

The treatment methods, design, construction, maintenance and management of the on-site system will take into account the regulations, guidelines, policies, and standards that have been established by the Nova Scotia Department of Environment, including Technical Guidelines for

<sup>3</sup> 60 persons x 180 L/person/day = 10,800 L x 14 days = 151,200 L (151 m<sup>3</sup> + security factor = 227 m<sup>3</sup>)

On-Site Sewage Disposal Systems and other guidance documents (NSE 1997; NSE 2006; NSE 2007; NSE 2013).

The location of the wastewater treatment system would likely be adjacent to the office and maintenance shops shown on **Figure 3.0-20**.

### Stormwater and Wash Water

Stormwater at the Black Point operation will include surface water runoff from precipitation (including snowmelt) falling on the processing and quarry areas. Within the pit, this will also include minimal groundwater inflows described in the Hydrogeological Technical Study (**Appendix A**). Wash water will consist of collected stormwater and will be used in the granite washing process to remove fines from the granite in the processing plant. This water will be collected and reused.

Stormwater and wash water from the processing area (the lower platform) will be managed by sloping the processing area so that water is directed away from the Chedabucto Bay to one of two settling ponds located along the base of the cliff at the southern edge of the lower platform. The two 6,100 m<sup>3</sup> settling ponds are sized to provide sufficient retention time for any suspended solids (rock fines) to settle out leaving clarified water. Stormwater retention ponds are sized to comply with NSE 1988 Erosion and Sedimentation Control Handbook guidelines, which equates to 11 days residence time for mean annual runoff through the ponds (please see the Surface Water Technical Report, **Appendix C**). The clarified water will be reused for product washing and site dust control, or tested and discharged if needed. Any excess untreated water can be pumped to the pit sump described below. Should a power failure occur, the settling ponds can be allowed to overflow, since the water will simply accumulate around the ponds rather than flow to Chedabucto Bay. This will allow containment and eventual treatment of the entire storm event.

In the quarry stormwater will be routed by sloping and shallow drainage ditches to the quarry floor for collection in the pit sump. The pit sump consists of a large excavated basin designed to retain water for reuse. Initially, the pit sump will measure approximately 45 x 60 m with a depth of 4.5 m and a volume of 12,000 m<sup>3</sup>. The sump can be expanded proportionally as the quarry expands through Phase 3 (64,000 m<sup>3</sup>), and Phase 5 (386,000 m<sup>3</sup>). As is the case with the retention ponds in the processing area, the pit sump can overflow with no negative effect on operations. In the event of overflow, water would be allowed to clarify in place prior to testing and discharge to the ocean, or would be pumped to the settling ponds for clarification.

The Project is designed to allow pumping of water from the settling ponds to the quarry sump and vice versa in a closed loop recycling process to ensure sufficient wash water is present at all times. The combination of retention ponds, quarry sump and land sloping is adequate to contain a 100-year 24 hour storm event.

The water management system will be designed to provide capability for non-routine discharges of clean water from the quarry sump. Any discharge to the ocean will be required as a minimum to meet water quality standards listed in the Pit and Quarry Guidelines (NSEL 1999) as well as quality criteria stipulated in the operating permits and authorisations. These criteria will include for example total dissolved solids, pH, oil and grease, nitrates and other constituents required by the permitting agencies. The final location of the discharge point will be established during the detailed design phase but is anticipated to be in the southwest zone of the lower platform nearest to the settling ponds. The quality of any discharged water is expected to be equivalent



to or better than the highly acidic surface discharges currently received from Fogherty Lake and Murphys Lake.

### **3.3.8 Other Waste**

The project will generate various types of waste and recyclable materials as a result of construction activity, and routine operation of the facility. The materials that will be generated include:

- Non saleable crushed granite, termed product fines, granite fines or crusher fines (crusher fines is the term used in this EIS).
- Typical “curbside” solid waste. This will include paper, plastic, cardboard, food scraps, aluminum cans, glass bottles and containers, and other trash. Much of this material will be collected in dedicated containers for recycling. Small volumes of medical waste may also be generated on occasion.
- Vehicle and equipment maintenance waste. Routine maintenance activities will generate a variety of waste materials including used antifreeze, used oil and hydraulic fluids, paint, used oil and fuel filters, spent batteries, tires, conveyor belting, miscellaneous equipment parts, scrap steel, wood pallets, light bulbs, petroleum contaminated rags and other petroleum contaminated media (pads, soil, granite fines, rags).

The Proponent’s approach to waste management is to use pollution prevention techniques to minimize the amount and types of waste materials. This also reduces the amount of material shipped off-site for disposal which reduces the risk of liability associated with the off-site disposal site. All wastes will be sorted and transported to a licensed recycling facility using authorized local services in compliance with the Nova Scotia Solid-Waste Resource Management Regulations and municipal requirements. Materials that cannot be recycled will be managed using authorized landfills for disposal. All waste materials and materials awaiting shipment or pick-up will be properly stored to prevent accidental release of substances to the environment.

### **3.3.9 Operation Related Noise and Light**

The Black Point operation will generate noise from the operation of mobile equipment, the processing plant, blasting and product loadout at the marine terminal (please see Section 6.3 for more information on anticipated noise levels).

The facility will employ a number of noise mitigation measures consistent with guidance presented in resource materials provided to the Proponent by Health Canada. These measures will both reduce noise at the source and reduce noise emanating from the facility through attenuation by design. Together, these measures will reduce noise levels outside the property boundaries. Noise reduction and mitigation measures will include:

- specification of reduced noise equipment, especially mobile equipment;
- procurement of equipment that meets US EPA Category IV air emission standards for off-road diesel equipment which tend to generate less noise than older equipment;
- confinement of most mobile equipment within the quarry pit below ground surface so the pit walls will attenuate noise levels;
- retention of natural barriers such as hillsides to the extent possible;

- placing product stockpiles and other structures to attenuate the noise from the processing equipment;
- consideration of alternative back-up alarms systems for mobile equipment;
- enclosure of the majority of the screening towers to reduce noise transmission;
- restricting operating hours for the quarry and processing plants to 16-hours per day so that noise levels are reduced during night time; and
- restricting blasting to daytime hours and weekdays.

In addition, the Proponent will periodically measure noise levels of the equipment and operation using portable dosimeters and track the levels so that increasing noise levels that could indicate equipment issues can be identified and corrective action taken. The Proponent also conducts employee noise exposure monitoring as part of the Safety and Health program. The employee noise monitoring will identify issues with work place exposure to noise that will target the source of the noise internally to minimize the risk of a noise issue outside of the facility property. The Proponent will also maintain an open communication with the community and the neighbours in the Black Point vicinity to identify any concerns with noise levels so that the issue can be addressed. All of these measures, combined with the distance of the site operations from off-site noise receptors (homes), will ensure that the site complies with the Pit and Quarry Guidelines established for operational sound levels (NSEL 1999). These Guidelines stipulate that noise levels are not to exceed the following levels at the boundaries of the Project site:

- 65 dBA 0700 – 1900 hours (Days);
- 60 dBA 1900 – 2300 hours (Evenings); and
- 55 dBA 2300 – 0700 hours (Nights, Sunday and statutory holidays).

A comprehensive noise assessment has been prepared for the facility that included measurement of background noise levels at the site and in proximity to the nearby noise receptors, and estimation and modelling of projected noise impacts associated with the operation. The results of this assessment are provided in Section 6.3.

Operational impacts on human-perceived night time light levels are anticipated to be limited. This is because the site layout and natural terrain restrict direct line-of-site visibility of the operation from the east and west. The distance of the operation from the nearest residents, combined with 30 m wide forested coastal buffers (and undeveloped Black Point itself) will help minimize any impacts. The quarry will not be visible from Route 16 due to the distance, vertical change in topography, and forested slopes.

Light will be generated from vehicles using onsite access roads and parking lots, exterior lighting, and lighting of the marine terminal. Illumination will be minimized by shielding lights to shine only where needed to ensure the safety of employees. The facility lighting will also be designed to minimize impacts by controlling the intensity of the lighting sources used and by careful placement of light sources. To the extent possible lights will be located where structures, buildings and natural barriers block transmission in the direction where neighbours are present. Lighting will be reduced to a minimum level in non-operational areas during night time hours. Any maintenance activity will take into consideration light impacts and adjust to provide the light needed to safely perform the task while trying to minimize off-site impacts. Please see Sections 6.3 and 7.3 for additional detail regarding anticipated light emissions.

### **3.3.10 Air Emissions**

Dust emissions during all phases of the Project will be controlled with the application of water obtained from the settling ponds and water that has pooled on the quarry floor and collected in the quarry sump. Biodegradable products proven to significantly minimize fugitive dust may also be used following approval from NSE. To minimize dust emissions associated with truck traffic, conveyors will be used to transport rock from the pit to the laydown area. Processing equipment will be designed to minimize drop heights at transfer points and certain equipment will be fitted with water spray nozzles for dust control.

Combustion emissions will be generated from all phases of the Project as a result of fuel combustion in Project equipment and vehicles. Specific emissions associated with the Project include: sulphur dioxide (SO<sub>2</sub>), nitrogen oxides (NO<sub>x</sub>), volatile organic compounds (VOCs), carbon monoxide (CO), carbon dioxide (CO<sub>2</sub>), and trace products of particulate matter (PM). These combustion related emissions will be minimized through the use of mobile equipment and electrical generators that meet US and Canadian Category IV emissions standards. These emissions are also minimized through the use of ultra low sulphur fuel in on-site mobile and fixed equipment. The use of conveyors will reduce trucking emissions; regular equipment maintenance and reduction of idling time will also ensure emissions are reduced.

The air quality impacts of the estimated emissions of dust particles and combustion related compounds were determined through the use of air quality dispersion modelling (Section 7.1 Air Quality and Climate Change and **Appendix O**). The modelling results were compared to federal and provincial air quality standards to assess potential Project-related impacts. The air quality assessment demonstrates that the Project emissions will not exceed applicable ambient air quality standards at any locations where off-site receptors (residences) are present.

Visible emissions monitoring will be conducted following installation and the start of operation of each crusher, screen, conveyor, and other pieces of processing equipment that is not wet. Compliance with applicable opacity standards will be confirmed and if found to be non-compliant, improvements in dust control will be implemented to achieve compliance before the equipment is returned to full operation. Daily visual observations of the operational areas including the processing plant and loadout areas, haul roads and stockpiles will be performed by site management personnel and any areas with visible dust will receive additional water applications, adjustments dust control equipment to improve effectiveness, or if the issue cannot be immediately corrected, by shutting down the equipment or area until corrective measures can be taken. The Proponent will apply adaptive management techniques and use the monitoring results to guide decision-making on an ongoing basis throughout each operating day.

The estimated annual emissions for each of the five operational phases are provided in Table 3.3. These values are maximums for peak production amounts anticipated in each phase.

**Table 3.3:  
 Total Criteria Pollutant Emissions from Quarry and Processing Plant (tonnes/year)**

Project Phase	Total Suspended Particulate (TSP)	Particulate Matter <10 microns (PM10)	Particulate Matter <2.5 micros (PM2.5)	Nitrogen Dioxide (NO2)	Carbon Monoxide (CO)	Volatile Organic Compounds (VOCs)	Sulfur Dioxide (SO2)
Phase 1	6.16	1.83	0.76	30.64	24.99	3.39	1.48
Phase 2	22.78	6.31	2.70	54.12	36.15	6.12	1.60
Phase 3	47.09	14.58	2.92	77.50	62.48	8.33	2.00
Phase 4	99.84	33.42	6.19	91.76	92.15	9.87	2.00
Phase 5	114.56	37.44	7.28	105.35	109.07	11.08	2.80

(source: Vulcan Materials Company)

### Greenhouse Gas Emissions

The Black Point quarry, processing plant and loadout operations will result in the direct emissions of greenhouse gases, primarily carbon dioxide (CO<sub>2</sub>) and to a lesser extent methane (CH<sub>4</sub>) and nitrous oxide (N<sub>2</sub>O). These gases are combustion by-products from fuels used in mobile equipment and the diesel powered engines associated with the portable processing plant in operational Phase 1 through Phase 3. A small amount of greenhouse gases are also generated on a discontinuous basis from blasting within the quarry pit. The estimated amount of greenhouse gases generated as direct emissions by the land based operations (excluding marine terminal) are 4,793 annual tonnes of carbon dioxide equivalent (CO<sub>2</sub>e) emissions during Phase 1. GHGs from the marine terminal are described later in this section.

The levels of greenhouse gas emissions increase proportionally as production increases, to a maximum estimated emission level (land based only) of 8,522 tonnes of CO<sub>2</sub>e annually during Phase 5. The estimated amounts of direct greenhouse gas emissions by operating phase are presented in Table 3.4.

**Table 3.4:  
 Tier I - Direct GHG Emissions Quarry, Processing Plant and Loadout**

Project Phase	CO2 (tonnes/yr)	CH4 (tonnes/yr)	N2O (tonnes/yr)	CO2e (tonnes/yr)
Phase 1	4,708.00	5.40	79.90	4,793.30
Phase 2	7,195.00	8.20	122.20	7,325.40
Phase 3	6,421.00	7.30	109.00	6,537.30
Phase 4	8,330.00	9.50	141.50	8,481.00
Phase 5	8,371.00	9.60	142.00	8,522.60

(source: Vulcan Materials Company)



The Black Point project will require approximately 9,000 kilowatts of electrical power primarily for the operation of the processing plant equipment in Phases 4 and 5. This amount of electricity generation by the electric utility will result in an indirect greenhouse gas emission rate of 1,058 tonnes of CO<sub>2</sub>e per year during peak production in Phase V. Lesser amounts of electricity will be needed in earlier phases. The indirect emissions due to electricity utilization are resented in Table 3.5.

**Table 3.5:**  
**Tier II - Indirect GHG Emissions for Electric Power Usage**

Project Phase	Maximum Electricity Demand (Horsepower)	CO2 (tonnes/yr)	CH4 (tonnes/yr)	N2O (tonnes/yr)	CO2e (tonnes/yr)
Phase 1	180	15.78	0.02	0.06	15.86
Phase 2	180	15.78	0.02	0.06	15.86
Phase 3	180	15.78	0.02	0.06	15.86
Phase 4	12000	1,052.09	1.05	4.31	1,057.46
Phase 5	12000	1,052.09	1.05	4.31	1,057.46

(source: Vulcan Materials Company)

### **3.3.11 Marine Vessel Operations**

The typical vessel used to transport aggregate is a 70,000 DWT “Panamax” size ship (**Figure 3.0-28**). During the initial stages of production before the plant is operating at maximum capacity, ships will arrive at the terminal on average approximately 1 to 3 times per month. As market conditions warrant, this will increase to a maximum of 1 to 2 ships per week. Ship loading typically requires 18 to 24 hours and so a typical cycle of arrival–berthing-loading-departure requires on average one to two days. Aggregate products will be the only material off-loaded at the Project site. Shipping will typically be arranged through the customers, who will arrange for ship arrival and departure at the marine terminal.

Operating limits for the marine terminal will be established during the final marine terminal design stage. The Environmental Management Plan will define the operating limits for the vessel to remain alongside the terminal will be developed. The Plan will identify and establish limits for severe atmospheric and/or oceanographic conditions for all marine terminal activities including berthing, mooring, and aggregate loading. The vessel will vacate the berth if and when these limits are reached.



**Figure 3.0-28:  
“Panamax” Size Ship**



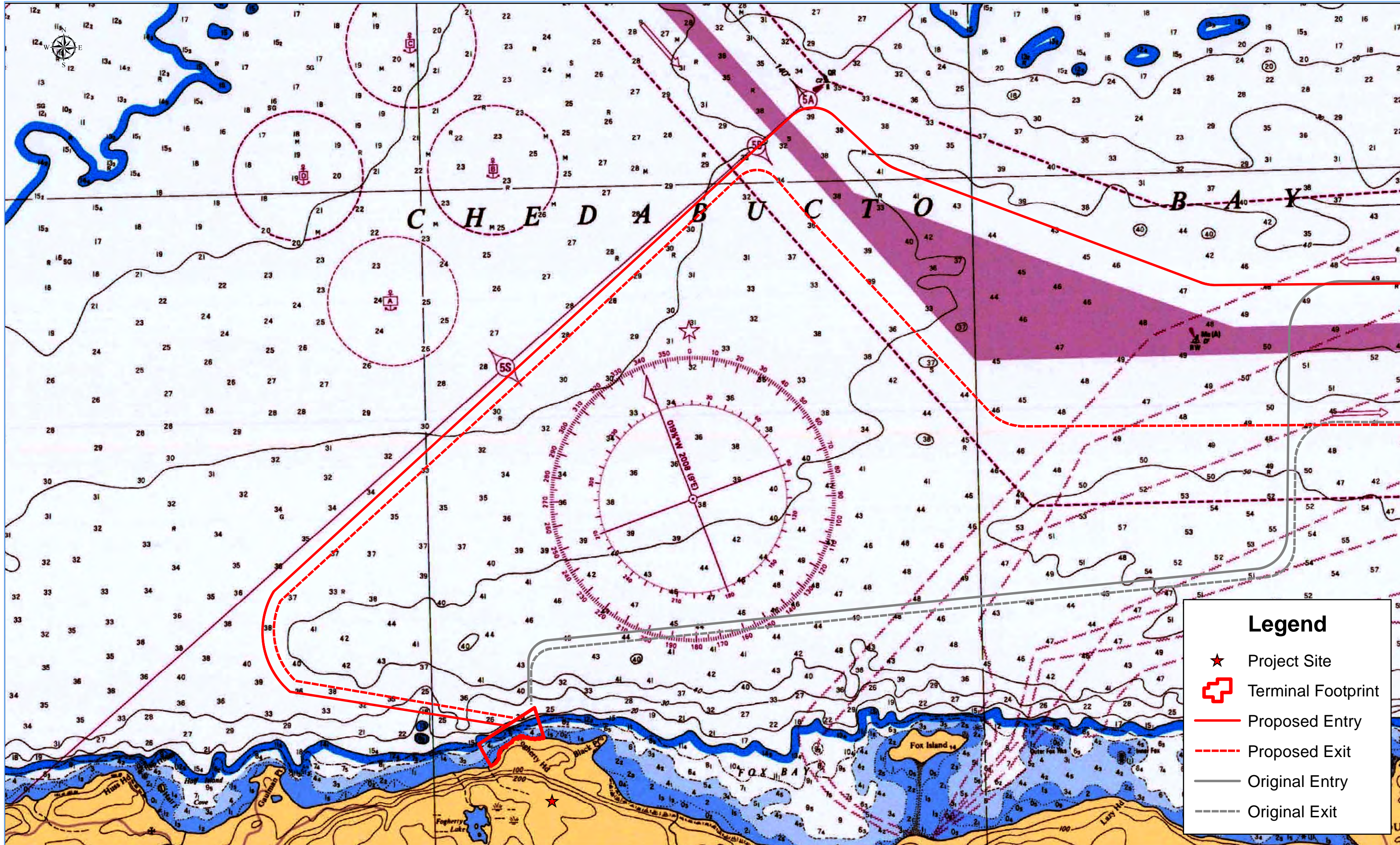

### Legend

- ★ Project Site
- ☒ Terminal Footprint
- Proposed Entry
- - - Proposed Exit
- Original Entry
- - - Original Exit

The proposed shipping route is for discussion purposes.  
 The actual shipping route is subject to ongoing transportation studies and government approval.

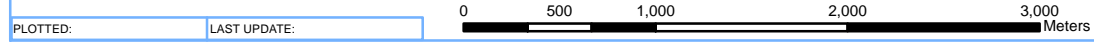

DATE	REVISION	BY	ISSUE DATE:

THIS DRAWING IN DESIGN AND DETAILS IS THE PROPERTY OF VULCAN MATERIALS COMPANY AND MUST BE RETURNED UPON DEMAND. THIS DRAWING MUST NOT BE COPIED, REPRODUCED, OR USED WITHOUT PERMISSION.



Proposed Shipping Routes

REGION	NOVA SCOTIA	PLANT	BLACK POINT
DRAWN BY	CKR	DATE	09/23/2014
SCALE	1 in = 1,000 m	DWG. NO.	Figure 3.0-29



A proposed shipping route from the inbound shipping lane to the marine terminal is shown on **Figure 3.0-29**. Two routes have been examined and after consultation with local fishermen, a preferred route was selected. It should be noted that the route used on any given voyage will depend on weather, traffic, safety, local pilot instructions and other factors. Due to the large size of vessels, speeds within Chedabucto Bay during the approach to the terminal are anticipated to be less than 2 knots. Elsewhere with the Bay, vessel speed would be at the Master's discretion under the pilot's advice. Outside of Chedabucto Bay, ships will generally travel at a speed of 14 knots.

If severe weather is forecast, the ship captain in consultation with the local pilot assigned to the vessel will determine the appropriate course of action. Ship crews will be fully trained of their responsibilities in the event of a weather-induced emergency at sea, and proper emergency response and escape equipment will be onboard at all times. If an instance of severe weather develops, the marine terminal may be used as a refuge for fishing boats or ships in the immediate area.

Ships are to adhere to all relevant laws, regulations and permits to ensure environmental compliance, and meet all regulatory standards pursuant to the *Canada Shipping Act*, including, but not limited to the:

- *Ballast Water Control and Management Regulations;*
- *Navigation Safety Regulations; and*
- *Ship Station (Radio) Regulations.*

It should be noted that no fuel tanker vessel traffic will occur as a part of the Project. There will be no bulk fuel or oil transport or transfer to or from ships while at the marine terminal and bilge water and deck wash discharge at the terminal will only occur in compliance with the federal government's *Ballast Water Control and Management Regulations*. Additional detail on bilge and ballast water management is provided in Section 6.11 Shipping and Navigation.

### **3.3.12 Emissions to Atmosphere from Marine Operations**

The Project will result in air emissions of dust (particulates) and fuel combustion byproducts emitted by ships during transport and loading operations. The combustion related emissions will include: sulphur dioxide (SO<sub>2</sub>), nitrogen oxides (NO<sub>x</sub>), volatile organic compounds (VOCs), carbon monoxide (CO), carbon dioxide (CO<sub>2</sub>), and trace products of particulate matter (PM).

Estimates of direct GHG emissions associated with ship operations and product transfer are presented in Table 3.6. The emissions estimates were prepared using factors provided in "Environment Canada GHG Emission Quantification Guidance for Fuel Combustion" using the mobile equipment guidance for light oil fuelled ships<sup>4</sup>. The fuel consumption values used in to prepare the estimates were 4.6 tons per day docked and 37.1 tons per day in transit.

---

<sup>4</sup> <http://www.ec.gc.ca/ges-ghg/default.asp?lang=En&n=AC2B7641-1#section5>



The GHG emissions associated with the berthing of the ship during loading at the marine terminal and the emissions associated with manoeuvring within the Project operating area are presented in Table 3.6.

**Table 3.6:**  
**Tier I - Direct GHG Emissions from Vessel Operations at Marine Terminal**

Project Phase	CO2 (tonnes/yr)	CH4 (tonnes/yr)	N2O (tonnes/yr)	CO2e (tonnes/yr)
Phase 1	201.37	0.40	0.00	201.77
Phase 2	279.67	0.56	0.00	280.24
Phase 3	425.11	0.85	0.01	425.96
Phase 4	626.47	1.25	0.01	627.73
Phase 5	939.71	1.87	0.02	941.59

(source: Vulcan Materials Company)

The greenhouse gas emissions for roundtrip vessel travel between the Black Point project boundary and the edge of Canadian economic zone waters are provided in Table 3.7. This information is based on an estimated vessel travel distance of 500 km round trip which will vary based on the specific route each vessel navigates.

**Table 3.7:**  
**Emissions for Total Annual Vessel Haulage (To/From Canadian Economic Zone Edge)**

Project Phase	CO2 (tonnes/yr)	CH4 (tonnes/yr)	N2O (tonnes/yr)	CO2e (tonnes/yr)
Phase 1	3,240.00	0.58	2.42	3,243.01
Phase 2	4,500.00	0.81	3.36	4,504.17
Phase 3	6,840.00	1.23	5.11	6,846.35
Phase 4	10,080.00	1.82	7.53	10,089.35
Phase 5	15,120.00	2.73	11.30	15,134.03

The Canadian National GHG Inventory for the 2012 calendar year shows the carbon dioxide equivalent emission levels for Nova Scotia to be 17,400 kt with 11,700 of that amount from stationary combustion sources and 5,530 for transport emission sources. The mining and oil and gas industrial category generated 201 kt of emissions.

Unlike priority pollutant air contaminants such as NOx and CO there are no ambient air quality standards for greenhouse gases. In addition, the impact of greenhouse gas emissions on the environment is cumulative in nature and is supplemented by natural processes such as volcanic eruptions. The impact of the Project's greenhouse gas emissions can be evaluated through a

comparison of the Project emission levels to both the levels of emissions in Nova Scotia in general and to the emission levels of similar industries.

The Project's total GHG emission level at the maximum generation rate during Phase 5 is estimated at 9,464 tonnes per year CO<sub>2</sub>e. This level is roughly 0.05% of the Province's total GHG emissions for 2012 of 17,400,000. The Project GHG emission level is also roughly 4.7% of the 2012 reported emissions of the mining and oil and gas industrial category. The Project represents 0.0000283 percent of the 2012 World Wide emissions for the fuel combustion and cement production source categories.

The Project's greenhouse gas emissions will not contribute significantly to these emissions levels. The Proponent will minimize GHG emissions by purchasing heavy off-road mining equipment that meet the US EPA and Canadian Tier 4 engine standards, operating mobile equipment with fuel efficiency in mind by eliminating unnecessary idling and shutting off equipment when it is parked (unless there is a safety or maintenance reason it is running), utilizing conveyors in the process to reduce the need for mobile equipment, and through the use of ocean vessels to ship the product reducing more energy intensive ground transportation options. This last point is illustrated in Table 3.8. This table summarizes the GHG savings of shipment achieved through the use of ocean vessels versus rail and truck. The GHG emission savings are dramatic ranging from 19% to 89% per vessel shipment.

**Table 3.8:  
 Vessel Operation GHG Analysis**

CO <sub>2</sub> e Emissions Vessel Travel to Delivery Point (tonnes/trip)				GHG Emissions CO <sub>2</sub> e	
North Caroline to Virginia Area	Charleston, SC	Miami, FI	Tampa, FL	Total By Phase	
611	683.00	1,013.00	1,283.00	Phase I	16,155.00
Alternatives Analysis				Phase II	22,437.50
Land Shipment from Vulcan Quarry to Same Market Area				Phase III	34,105.00
GHG CO <sub>2</sub> e Per Equivalent Single Vessel Shipment				Phase IV	50,260.00
752	1,505.00	8,986.00	5,354.00	Phase V	75,390.00
% GHG Reduction by Ocean Vessel Shipping (per ship trip)				Phase V Annual CO <sub>2</sub> e Savings (tonnes)	
18.8%	54.6%	88.7%	76.0%	273,147	

(source: Vulcan Materials Company)

### 3.4 DECOMMISSIONING PHASE

#### 3.4.1 Transfer of Ownership and Control

The Proponent will lease the property from the MODG for the life of the quarry, estimated to be sometime after 2070. The land will be returned to the MODG following the completion of operations, equipment decommissioning, removal of plant and marine terminal infrastructure, and the acceptance of site decommissioning and reclamation activities.

A description of the site following operations and decommissioning activities and details of a conceptual rehabilitation plan are provided in the following sections.

### **3.4.2 Rehabilitation Plan**

In accordance with the requirements of the provincial Pit and Quarry Guidelines (NSEL 1999), the Proponent will prepare a written plan approved by NSE to provide for partial or total abandonment and rehabilitation of the site. It is anticipated that the plan will include an initial rehabilitation plan, progressive rehabilitation measures and / or a final rehabilitation plan. The Proponent will also post interim and final security bonds for the quarry, as required by the Pit and Quarry Guidelines and the *Approval and Notification Procedure Regulations*.

The rehabilitation plan will be developed for the Project site and submitted to regulators for review as part of the provincial Part V Industrial Approval application. The plan will include short-term and long-term reclamation efforts as well as details of the proposed final reclamation plan such as topography, maximum slopes, re-vegetation plans, and potential future land uses once the quarry operation is complete.

All areas of the Project site affected by quarry activities including the plant site and settling ponds, marine terminal, access roads and the quarry floor will be included in the rehabilitation program. The final reclamation plan will be developed in consultation with various stakeholders such as provincial and municipal officials, non-government organizations and conservation groups, adjacent landowners, and Mi'kmaq representatives. A draft Table of Contents is given below.

#### **Rehabilitation Plan Draft Table of Contents**

- 1.0 Introduction
- 2.0 Baseline Information
- 3.0 Project Facilities and Areas
  - 3.1. Open Pit
  - 3.2. Processing Plant
  - 3.3. Marine Terminal
  - 3.4. Infrastructure
  - 3.5. Water Supply, Treatment, and Discharge
- 4.0 Conceptual Decommissioning and Reclamation Plan
  - 4.1. Site at Closure
  - 4.2 General Strategies
    - 4.2.1 End Use Objectives
    - 4.2.2 Goals
    - 4.2.3 Plan for Managing Surficial Materials
    - 4.2.4 Plan for Managing Re-Vegetation
    - 4.2.5 Plan for Water Management

- 4.3 Specific Strategies for Project Facilities
  - 4.3.1 Infrastructure Removal
  - 4.3.2 Plant Equipment
  - 4.3.3 Mobile Equipment
  - 4.3.4 Marine Terminal
  - 4.3.5 Access Roads
  - 4.3.6 Open Pit
  - 4.3.7 Water Retention and Ponds
  - 4.3.8 Hazardous Materials Management
- 5.0 Site Safety and Security
- 6.0 Monitoring and Maintenance
  - 6.1. Site Maintenance
  - 6.2. Reclamation and Vegetation Monitoring
  - 6.3. Water Quality Monitoring
- 7.0 Schedule
- 8.0 Costs
- 9.0 References.

### **3.4.3 Site Description at Closure**

The site will include the following elements at the end of operations (**Figure 3.0-30**):

- An open pit that will be flooded to create an aquatic feature with viable habitat,
- Permanent submersion of the solid granite quarry floor and associated haul roads,
- A graded area including the plant site and material storage areas,
- Engineered ponds and sumps that supplied water to the processing plant,
- Minor disturbed areas immediately adjacent to the open pit,
- Appropriate surface water drainage structures (ditches, swales) in and around the Project site, and
- Site buildings and road(s) needed for care and maintenance of the site after operations end.

### **3.4.4 Reclamation Objectives**

The reclamation objective is to restore aquatic and terrestrial habitats to the extent possible so that indigenous flora and fauna can occupy or exploit areas recently used to support quarrying operations. The overall end use objective is to promote land uses and habitat types within the Project area that are similar to those that occurred before the Project was initiated. Other recreational or commercial land use opportunities may develop during the life span of the quarry and will be examined in coordination with the MODG and other stakeholders.

At closure, all unneeded buildings and equipment will be decommissioned and removed from the site. The water management system used during operations will be re-configured to ensure



stable site drainage and water quality that meets applicable standards for discharge. The landforms that remain after operations will be reclaimed to a variety of habitats, including upland forest, shrub-riparian, and rocky outcrop. These habitats will be most appropriate for wildlife use, with some potential for traditional and recreational use.

### **3.4.5 Reclamation Goals**

The goals during decommissioning and reclamation are to:

- Remove all equipment and buildings not necessary for future use and care of the site,
- Stabilize the terrestrial environment and replant native vegetation where applicable,
- Minimize disruption to the marine environment, and
- Restore land use potential.

Specific activities to be conducted during the decommissioning and reclamation process are described in further detail in the following sections.

### **3.4.6 Removal of Equipment and Infrastructure**

Following the completion of quarrying activities, estimated to be sometime after 2070, the site will be decommissioned as outlined in the reclamation plan (Section 3.4.2). As part of this plan, all equipment and related infrastructure including the processing plant, machinery and equipment will be removed from the site. The purpose of removing the equipment and infrastructure is improve site aesthetics and allow the site to return to a more natural looking state, while at the same timing decreasing the potential for environmental risk over the long-term if these materials were left on-site.

It should be noted that following de-commissioning the land-owner, the MODG, may request that some infrastructure be left on-site that might be beneficial for future land uses. It is anticipated that discussions with MODG regarding final reclamation and decommissioning of the site will take place as the operation nears completion.

Equipment and infrastructure to be removed include:

- Mobile equipment including trucks and loaders;
- All conveying, crushing and screening infrastructure, including:
  - Primary, secondary and tertiary crushers;
  - Conveyors and control towers;
  - Wash tower and screening facilities;
  - Pump facilities and pipes from settling ponds
- Surface buildings not required for future land use by MODG, including office facilities and maintenance buildings and equipment sheds;
- Infrastructure including:

- septic system(s);
- fuel storage facilities;
- Any garbage, waste and debris will be disposed of in an approved waste disposal site;

Factors to be considered during removal of equipment and infrastructure include:

- Minimizing lag time between retirement of buildings or structures and their disassembly;
- Keeping retired buildings closed to discourage colonization by wildlife;
- Disassembling buildings and structures outside of the breeding season for most birds (April 1 to September 1). Alternatively, inspecting buildings or structures just before disassembly to ensure they are not being used for nest sites in compliance with Migratory Birds Convention Act. Otherwise perform nest surveys and limit activities until nests are no longer occupied. Also contact relevant authorities prior to site decommissioning (e.g., Canadian Wildlife Service);
- Minimize lag time between completion of aggregate production and commencement of equipment and infrastructure removal.

Following the removal of all equipment and infrastructure, the plant site and administrative areas will be graded to allow for future commercial, industrial, recreational, or residential land use, or to allow for restoration of the area for wildlife habitat.

### **3.4.7 Removal of the Marine Terminal**

To avoid disturbance of the marine environment and enhance its potential for future use, the rubble mound, mooring dolphins, caissons, slewing rails, and buoys will likely be left in place. The shiploader arm and ancillary mechanical equipment including suspended conveyors, dust collectors, drive belts, and shuttle will be removed from the Project site.

### **3.4.8 Site Rehabilitation**

The Proponent will undertake a progressive reclamation program at the Project site during operations, which will include the use of Best Management Practices developed for quarry facilities; only the area needed for production in any one year, would be grubbed. The subsoil, topsoil and root mat of this area would be placed in a dedicated stockpile and similarly, any overburden would be stockpiled separately. This material will be used in future reclamation. The reclamation process begins after the environmental controls are in place.

Hydroseeding stockpiles may be used as an alternative to the use of root mat in future activities. This approach will provide a source of native plant species which are well adapted to local climatic and soil conditions, while also reducing the need for fertilizer use. If it is necessary, seeds of native plant species which are well established to Nova Scotia and which are not aggressive weeds in the local plant communities of the Project site will be used to stabilize soils during reclamation. This option will be used in the event that grubbed material has not produced sufficient plant biomass to stabilize soils. Re-vegetated areas will be monitored for up

to 5 years after decommissioning to ensure that a self-sustaining vegetation cover is successfully established.

As distinct areas of the quarry become inactive, these areas will be graded to a stable slope of 2:1, covered with overburden, and (if warranted) seeded in the absence of laying a root mat. Within six (6) months of abandoning quarry operations, the rehabilitation of the site will have achieved:

- grading and contouring of all slopes and exposed rock faces, to the extent practical, in consideration of rock falls, slope stability, and safety;
- spreading stockpiled overburden and topsoil; and
- hydroseeding in the absence of laying a root mat.

The laydown (covered with quarried materials) and administrative areas (following the removal of all structures) will be graded, as required to allow for future commercial, industrial, recreational, or residential land use, or to allow for restoration of the area to existing conditions (wildlife habitat). An example of the potential end use is shown on **Figure 3.0-30**.

An Environmental Management Plan (EMP) will be developed for the Project and will include a number of mitigation measures that will address aspects of the Project including site rehabilitation. The Project EMP will ensure Project activities adhere to all relevant federal and provincial regulations (e.g. *MBCA, SARA, etc.*).

### **3.4.9 Reclamation Phasing Timeline**

The following table provides an estimated timeline for reclamation activities.

**Table 3.9  
 Reclamation Phasing Timeline**

Activity	Anticipated Start Date	Anticipated Completion Date
Best Management Practices	2018	2070+
Operations	2021	2070+
Decommissioning (Equipment, Plant, Marine Terminal)	2070	2072
Reclamation	2072	2073
Monitoring and Acceptance	2073	2078

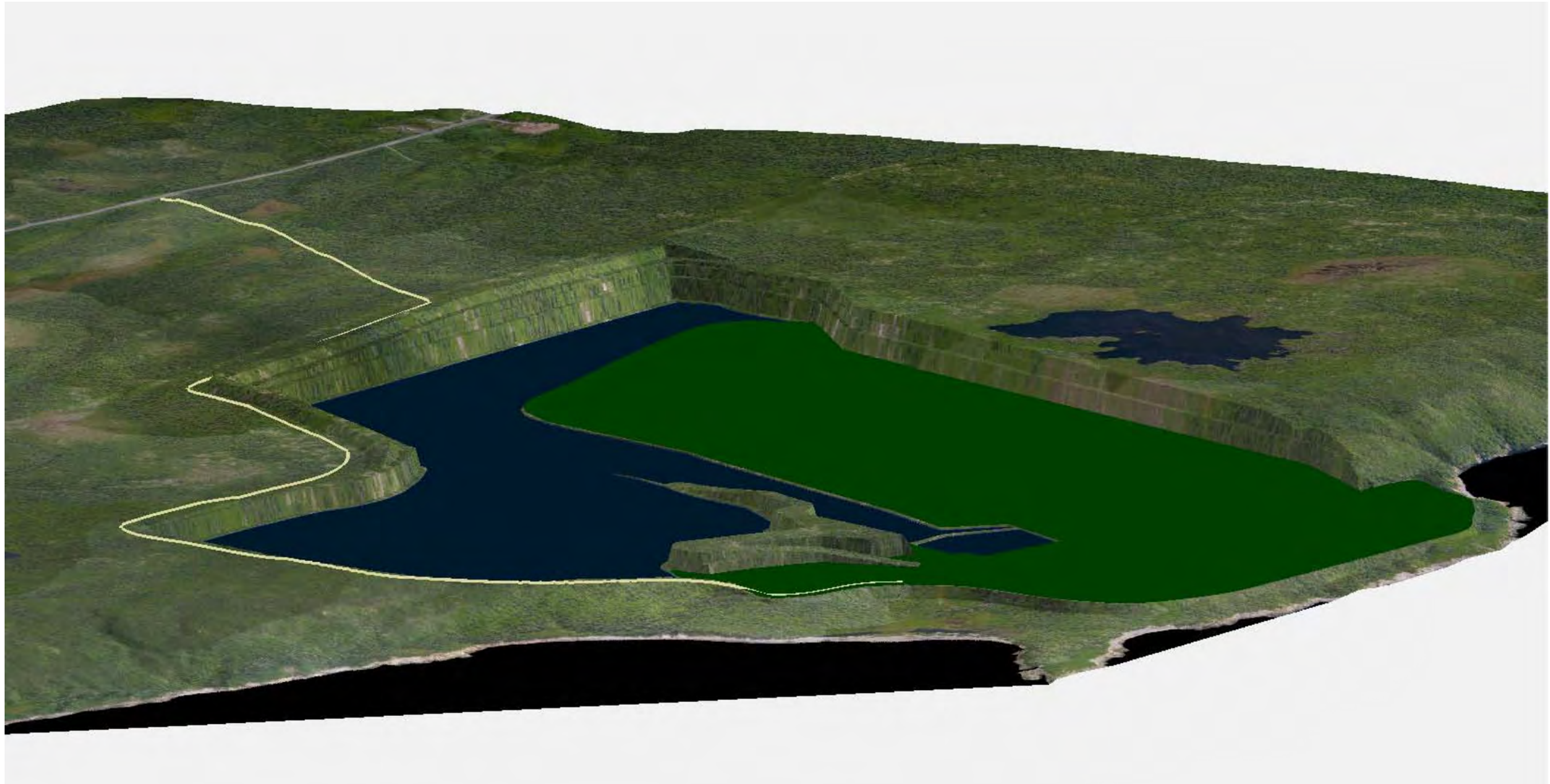

PLOTTED: LAST UPDATE:



DATE	REVISION	BY	ISSUE DATE:

THIS DRAWING IN DESIGN AND DETAILS IS THE PROPERTY OF VULCAN MATERIALS COMPANY AND MUST BE RETURNED UPON DEMAND. THIS DRAWING MUST NOT BE COPIED, REPRODUCED, OR USED WITHOUT PERMISSION.



Potential End Use

REGION	NOVA SCOTIA	PLANT	BLACK POINT
DRAWN BY	CKR	DATE	10/22/2014
CHECKED BY		SCALE	No scale
JOB NO.			

DWG. NO. Figure 3.0-30



### **3.5 ACCIDENTS AND MALFUNCTIONS**

Malfunctions and accidental events will be prevented and mitigated through a systematic approach to worker health and safety and environmental protection. Contractors will be required to submit health and safety policies and plans to the Proponent for review and approval prior to any onsite activities. Onsite workers will receive appropriate training to prevent and mitigate workplace accidents and environmental upsets.

The accidents and malfunctions that could potentially occur during site preparation and construction, any phase of operations, and the site decommissioning and closure phases of the Project are described below, while accident scenarios are described systematically in Section 7.18. Mitigation measures to prevent the occurrence of such events, and response procedures to be implemented in the event they do occur, are also described in Section 7.18 and will be developed in more detail as part of the Industrial Approval application process.

#### **3.5.1 Fuel and Hazardous Materials Spills**

##### Quarry, Plant, Shop and Loadout Areas

All phases of the Project (site preparation, construction, operation, closure and decommissioning) will include the use of fuels and equipment maintenance and servicing fluids. The fuels will include diesel fuel and gasoline required to operate the mobile equipment and portable generators (note: the generators will be discontinued following Phase 3). The equipment maintenance and servicing fluids include hydraulic oils, various viscosity grades of oils and lubricants, greases, antifreeze, brake and steering fluids, small quantities of other maintenance aids such as paints, WD40, and other solvents. Site development and quarry operations will also use blasting agents that may include diesel fuel and ammonium nitrate as components.

The potential for spills or leaks of any of these materials exists during all phases of the Project. The spills could result from equipment failure, damage to storage or piping systems, mobile equipment accidents, or failure to follow proper procedures related to fuel and other bulk material transfers or equipment maintenance activities. In the unlikely event of a large spill or leak, soil, groundwater and surface water contamination may occur, adversely affecting the quality of habitats and/or resulting in ingestion or uptake of contaminants by wildlife.

The risk to the environment from spills or releases of fuel and other substances is mitigated through a series of activities and controls. Any large spill event would be associated with materials stored in bulk quantities at the maintenance shop, primarily fuels and some lubricating oils. Materials stored on site in bulk will be stored in above ground storage reservoirs with secondary containment in compliance with provincial regulation. Any spillage inside the containment will be recovered and managed in accordance with provincial waste management requirements.

The processing plant area is designed to provide protection from fuel or other material spills. The main processing plant and shop area will be sloped to the south so that any spilled liquids will remain on-site. Larger spills could potentially be directed to the processing plant settling basins where the spilled material would be recovered. In the event that a settling basin is used to manage a large spill, the basin pump used to provide wash water would be shut off until the

spilled material has been recovered. In all cases, the spilled material will be contained and recovered as quickly as possible.

As required by workplace health and safety regulation, the employees working at Black Point will be trained in spill response procedures. Spill response materials (absorbents, pads, socks, booms) will be available in proximity to areas where fuels and other materials are located. Most spills or leaks will be localized near the source and be addressed by site personnel using the available spill response equipment. All fuel, chemicals and wastes will be handled in a manner that minimizes or eliminates the risk of spillage and accidents. In the event of any spill or leak at the site, immediate action will be taken to stop the leak and contain the spilled material. All contaminated material will be collected and stored in an appropriate manner so as to not result in a re-release to the environment until such a time as it will be transported to an approved treatment / disposal facility. All spills will be reported to the 24-hour environmental emergencies reporting system (1-800-565-1633) in accordance with the *Emergency Spill Regulations* enacted under the Nova Scotia *Environment Act*. As well, spills that contravene the provisions of CEPA 1999 will be reported to a federal enforcement officer and the public as required under CEPA 1999 (s. 212). A Spill Contingency Plan will be developed in support of the application for provincial Industrial Approval.

The Black Point facility will use best practices during fuel and other liquid transfer operations including monitoring and oversight of the transfer activities and verification to ensure that the receiving container has adequate capacity prior to beginning the transfer procedure. Tanks will be designed with level monitoring and overflow protection in accordance with prevailing provincial regulations.

All Project equipment and vehicles will meet industry standard requirements and be safety certified and fit for their intended use. Regular pre-shift inspections and maintenance programs will ensure the continued reliability and integrity of Project equipment. Necessary critical spares will be maintained in the event that an equipment change-out is required.

The Proponent will have a written agreement in place with a certified emergency response company (e.g., Emergency Services International; Kildoon Emergency Management Training) to provide land and water based spill response services prior to the initiation of Project construction activities.

### Marine Terminal and Ship Operations

The risk of a fuel or hazardous substance release at the marine terminal is minimal because the facility will not be transferring fuel, ballast water, sewage, ship waste or any other material apart from the crushed stone aggregate between the ship and shore.

The ships will arrive “ballasted” and ballast water will be discharged during the loading. Ballast discharge is governed by the *Canadian Ballast Water Control and Management Regulations* (SOR/2011-237) as well as the International Marine Organization (IMO) International Convention for the Control and Management of Ships’ Ballast Water and Sediments. Compliance with the regulations and guidelines minimizes the risk of transfer of invasive species due to ballast water. Ships are required to comply with the ballast water exchange regulations unless they have a ballast water treatment system on board or retain ballast within the ship.

The requirements regarding ballast exchange vary based on the ship's route of travel and origin. Ships that originate and took on ballast water within waters under Canadian jurisdiction are not required to exchange ballast water before discharging. Ships originating outside of Canadian jurisdiction that took on ballast water outside of Canadian waters are required to exchange the ballast water at least 200 nautical miles outside of Canadian waters in water at least 2,000 deep. Ships coming into Black Point will be required to comply with the *Canadian Ballast Water Control and Management Regulations* and to maintain a Ballast Water Management Plan. The enforcement of these requirements is the responsibility of Transport Canada.

There is a potential for liquid spills or releases in the event of an accident that results in damage to the ship's hull sufficient to rupture a fuel tank, bilge water tank, or other ship structure that contains fuels, lubricating oils, hydraulic fluids, bilge or ballast water. Such an incident would release the affected material into the coastal waters. Factors such as the spill volume and composition, wave, current and wind conditions, and the promptness and effectiveness of response efforts would affect the extent of impact associated with the event. These impacts may include damage to fisheries, impacts to aquatic flora and fauna and waterfowl, as well as coastal impacts from residual material coating the shoreline (please see Sections 6.11 Shipping and Navigation and Section 7.18 Accident and Malfunctions for more detail on these subjects).

The likelihood of a ship-to-ship collision event is low given the lack of significant large shipping traffic in the area of the marine terminal. A collision with a fishing vessel would not likely result in damage severe enough to cause a release. The predominant fuel used by Project vessels is marine diesel; this material is responsive to spill control agents and standard spill response measures. The Project will mitigate this risk by ensuring that ship docking at the terminal is tug and pilot assisted as needed and required by law, the terminal and mooring structures are properly constructed and well lit, and also by having a written agreement with a certified spill response contractor to provide response services in the event of a spill affecting the marine environment. Other mitigating factors include continual redesign of vessels being produced to make them less susceptible to collision damage. This will reduce this risk over the life of the Project. As previously noted, an Emergency Spill Response Plan and emergency response training will also be employed at the site.

### **3.5.2 Erosion and Sediment Control Failure**

The laydown area containing stockpiled materials will be designed to contain and direct runoff to the settling ponds and, under normal weather conditions, it is anticipated that there will be no water discharge from the operation. The engineered settling ponds cannot "fail" in the sense of a wall breach since they will be excavated into rock and bermed with several tens of meters of stone. The ponds may overflow, particularly during a prolonged or significant (i.e., 100-year) storm event but this overflow would not reach the ocean. In the event of an overflow, water would be contained within the site due to the south facing slope of the lower platform. The two ponds together will hold approximately 12,200 m<sup>3</sup> (approximately 3 million US gallons). Calculations indicate the lower platform can accommodate over 28,000 m<sup>3</sup> of water. This would flood a small portion of the lower platform to an approximately depth of 30 cm. Such a flood would temporarily halt operations in this area but would not, for example, affect processing plant machinery. This flooding would only occur if the electricity failed; should the electric pumps continue to function during a severe storm, then water can be transferred between the settling ponds and the pit sump. The water would be retained in the pit sump until clear, then tested and discharge if needed, or returned to settling ponds.

Additional temporary or permanent retention ponds may be installed elsewhere on the site during construction as required in NSE's Erosion and Sedimentation Control Handbook for Construction Sites (NSE 1988).

These areas, and erosion and sediment control measures installed elsewhere in the Project area, will be regularly inspected and monitored, particularly during and after extreme precipitation events. Erosion and sediment control structures found to be damaged will be repaired immediately and any other remedial action will be taken as necessary. Fines storage areas will be confined to areas within the quarry pit so any control failures would not result in an off-site release of material.

### **3.5.3 Vehicle and Vessel Collision**

#### **Vehicle Collisions**

Vehicular collisions may occur during any phase of the Project. The vehicles operating at the site will primarily be Project related mining equipment including bulldozers, haul trucks, loaders, service vehicles (pick-up trucks) and company cars. Any vehicles accessing the site will be required to have stated business and check-in at the office or scale house. Traffic patterns, speeds, and right-of-way signage and training will minimize the risk of vehicle collisions on the Project property. Operators of mobile equipment will receive initial and annual training on safe equipment operation and on issues such as awareness of blind spots.

#### **Vessel Collisions**

The risk of vessel collisions is primarily associated with Phases 3 through 5. There is the potential for Project related vessel collisions during construction and other operating periods and decommissioning, but the limited amount of marine activity during those phases reduces the potential risk. The management of marine traffic in Chedabucto Bay is under the responsibility of the Canadian Coast Guard. It is mandatory that all large vessel traffic report to the Canadian Coast Guard at specified points and take local pilots on board. The potential for collisions will be minimized through controlling vessel speed; scheduling and coordinating activities with other marine users, Transport Canada and the Canadian Coast Guard; and posting Notices to Mariners as needed. The marine terminal will contain navigational aids and anti-collision radar will provide early warning of a potential collision hazard. The Project will also use weather reports and wind speed information to monitor for changing weather conditions that could increase the risk of collisions during vessel navigation to or from the terminal. This mitigation measure will provide a level of protection in addition to that provided by the Coast Guard and the use of tugs and pilots for navigation support (please see Sections 6.11 Shipping and Navigation and Section 7.18 Accident and Malfunctions for more detail on these subjects).

### **3.5.4 Fire**

A fire at the Project site may occur during any phase of the Project due to an equipment accident, human carelessness, or natural causes such as a forest fire or lightning strike under dry conditions. The immediate concern for a fire is for human health and safety; additional concerns include habitat loss, direct mortality to wildlife, and loss or damage of property. The emissions from a fire would likely consist mainly of smoke (particulate matter) and CO<sub>2</sub>, but could also include CO, NO<sub>x</sub>, SO<sub>2</sub>, and other products of incomplete combustion. A large fire could create air contaminant levels greater than the ambient air quality standard over distances



of several kilometres; however, the likelihood of such cases is considered low and the event would be of short duration.

The risk of fire will be reduced by proper management of fuel and other flammable materials, and through appropriate operational procedures such as industry standard storage, handling and transfer techniques. The Emergency Response and Spill Contingency Plan, which will be prepared under the Environmental Management Plan as part of the Industrial Approval application process, will outline procedures for fire prevention, response and reporting. In the unlikely event of a large fire, local emergency response and firefighting capability will be called to respond to reduce the severity and extent of damage and to protect the safety of workers.

### **3.5.5 Health, Safety and Environmental Management**

A Project-specific Environmental Management Plan (EMP) will be prepared to describe the procedures required to meet regulatory obligations and mitigating measures and commitments made in this EIS. The purpose of the EMP is to:

- Ensure that the commitments to minimize environmental effects in general, and specific regulatory commitments and commitments and mitigating measures made in this EIS will be met;
- Provide concise and clear instructions regarding procedures for protecting the environment and minimizing potential environmental effects;
- Document environmental concerns and appropriate protection measures associated with Project activities;
- Provide a reference document for planning and / or conducting specific activities which may have an effect on the environment;
- Function as a training document / guide for environmental education and orientation; and
- Communicate changes in the program through the revision process.

Environmental management is considered an integral element in the way daily activities are undertaken. The Proponent is committed to upholding this position while complying with commitment as well as detailed Project requirements for environmental management to staff, contractors, regulatory agencies and the public. Those involved in the Project will then incorporate the environmental management practices into their daily work routine. The EMP will be used during site preparation and construction (and decommissioning and reclamation) and normal operating conditions at the site. The EMP will also detail the various monitoring programs to be undertaken before (baseline), during (compliance and environmental effects), and after the Project (ongoing environmental effects).

Development of the EMP will be done in consultation with regulatory agencies and will be completed in advance of the commencement of site preparation and construction.

## **Environmental Management Plan Draft Table of Contents**

### 1. Introduction

- 1.1. Commitment to Environment, Health and Safety
- 1.2. Purpose of the Environmental Management Plan
- 1.3. Scope, Organization and Maintenance

### 2. Responsibilities and Training

- 2.1. Environmental Management and Communications
- 2.2. Roles and Responsibilities
- 2.3. Training and Orientation Requirements

### 3. Summary of Key Environmental Issues and Environmentally Sensitive Areas

- 3.1. Marine Construction
- 3.2. Marine Fish and Water Quality
- 3.3. Marine Species at Risk
- 3.4. Wetlands
- 3.5. Watercourse Alterations
- 3.6. Terrestrial Fish and Fish Habitat
- 3.7. Terrestrial Species at Risk
- 3.8. Recreational and Commercial Fishing

### 4. Environmental Protection Procedures (EPP)

#### 4.1. Project Operation

##### 4.1.1. Generic Mitigation Measures and Best Management Practices

###### 4.1.1.1 *Generic Best Management Practices*

###### 4.1.1.2 *Erosion and Sediment Control Plan*

###### 4.1.1.3 *Stormwater Management Plan*

##### 4.1.2. Site Preparation Activities

##### 4.1.3. Watercourse Access Installation and Removal

##### 4.1.4. Marine Construction Activities

#### 4.2. Operations, Monitoring and Maintenance

##### 4.2.1 Inspections and Bird Monitoring

##### 4.2.2 Surface Water Discharge Monitoring

##### 4.2.3 Groundwater Monitoring

##### 4.2.4 Other Environmental and Compliance Monitoring

### 5. Waste Management

#### 5.1. Introduction

- 5.2. Waste Management
- 5.3. Equipment Fuelling and Hazardous Materials Management
- 6. Environmental Monitoring
  - 6.1. Baseline Monitoring
  - 6.2. Compliance Monitoring
  - 6.3. Environmental Effects Monitoring (EEM)
- 7. Emergency Response and Spill Contingency and Plans
  - 7.1. Spills
  - 7.2. Vessel Collision
  - 7.3. Fires
  - 7.4. Heritage and Archaeological Discovery
  - 7.5. Erosion Control Failure
- 8. Incident Reporting
- 9. Contact List
- 10. References

Sections 1 and 2 of the EMP will introduce the EMP and provide the overarching objectives, scope and organization of the document (Section 1) as well as the organizational structure for environmental management and the roles and responsibilities of key personnel (Section 2). Section 3 will provide a brief overview of the key environmental and socio-economic issues and concerns specifically associated with the Project.

Sections 4 and 5 of the document will include specific mitigation measures for various activities associated with each phase of the Project to ensure protection of the environment. This will include regulatory requirements, commitments made in this EIS. Mitigation measures will be provided based on standard construction practices and will be adapted as required to meet the specific needs of the Project and the area. For example, the EMP will include / indicate:

- The appropriate timing of in-water works;
- Pre-construction meeting requirements;
- Erosion and sediment control and storm water management;
- Requirements for vessel speeds and course;
- Site restoration and stabilization procedures;
- Spill prevention and response procedures; and
- Waste management and fuelling procedures.

Section 6 of the EMP will include the details of the various monitoring programs to be undertaken. These programs will be developed in consultation and co-operation with regulatory

agencies such as DFO and will include (among other information) descriptions of the equipment to be used, the frequency of the monitoring and reporting requirements.

Baseline monitoring in the Project area has begun and the data collected was used in support of this EIS. Additional information will be collected in advance of Project construction to build on initial work and help characterize pre-development conditions.

Compliance monitoring will be conducted throughout site preparation and construction, operations, monitoring and maintenance, and decommissioning and reclamation phases of the Project. Compliance monitoring is intended to ensure conformity with municipal, provincial, and federal legislation and any conditions of approval to the EIS imposed by regulatory agencies. Monitoring frequency will be at regular intervals, and in response to significant storm events to ensure erosion control structures are functioning. Monitoring and inspection personnel will also be available to provide guidance and support during construction in sensitive areas and / or during sensitive periods.

Section 7 of the EMP will include various contingency and emergency response plans for both land and marine activities. Section 8 will outline the incident reporting requirements and will provide the format and information that must be provided with each report. Incident reporting will include spills reporting and wildlife sightings.

Section 9 of the EMP will include a list of Proponent contacts and the various regulatory agencies that have and / or will be involved through the Project as well as emergency contacts.



## **4.0 ALTERNATIVES TO THE PROJECT**

### **4.1 Do Nothing Alternative**

The alternatives analysis uses a systematic approach to evaluate different methods of achieving the Project's goals. Each technically and economically feasible alternative is in turn subject to further analysis within the EIS report. The Project consists of the quarrying, crushing and marine transport of granite aggregate. Ultimately, the Project is intended to meet market demand for aggregate and bring value to the Proponent's shareholders and to local area residents.

The Proponent's economic analysis supports the current Project description and suggests that it is the most practical and economically feasible approach to this development (Erdene 2011). Given this, the only alternative to this undertaking is to not undertake the Project at all, referred to as the "Do-Nothing Alternative". Not implementing the Project would naturally result in the non-fulfillment of the Project's goals and is thus not an economically feasible alternative. Implementing the Project as proposed will result in residual positive and adverse environmental effects, but significant adverse effects are not likely to occur (please see Section 12 of this report). The Project is also expected to provide long-term local and regional economic benefits as described in Section 7.13 of this report. Without the Project, neither the adverse effects nor the economic benefits would be realized.

### **4.2 Assessment Methodology**

In the sections that follow, alternative means of undertaking the Project are described. Only those alternative means that are technically and economically feasible are further assessed with respect to their potential environmental and socio-economic impacts.

As a minimum the EIS Guidelines (CEA Agency 2014) require an alternative means assessment of the following subjects:

- Rock material extraction method
- Transportation methods/routes
- Construction methods for the marine terminal including management options for dredged material (on land versus at sea)
- Location of the marine terminal
- Location of stockpiles
- Location and type of waste management facilities
- Means of electrical generation

In addition to the components above, alternative quarry locations were evaluated and alternative quarrying methods were examined. Technical feasibility was assessed by the Vulcan project team based on their extensive experience at more than 200 operating quarries in the US Mexico, and the Bahamas. The relative economic feasibility each alternative was assessed based on anticipated capital, operating and lifecycle costs.

As outlined in the EIS Guidelines, the assessment methodology consisted of:

1. Determining the technical criteria by which feasibility is determined and using these criteria to identify and describe the technically and economically feasible alternative means to carry out the Project;
2. Establishing through qualitative means which of these alternatives is in fact technically and economically feasible;
3. Identifying the VCs potentially affected by each alternative means and examining the effects of the alternatives on each VC. This is undertaken with a specific focus on both environmental effects and effects on potential or established Aboriginal and Treaty rights and related interests.
4. Identifying the preferred means for undertaking the Project.

#### **4.3 Alternative Quarry Locations**

A multi-year aggregate exploration and reconnaissance program was undertaken by the Proponent to investigate potential quarry sites in the Maritimes, concentrating on Nova Scotia due to its southerly location with respect to markets on the US east and Gulf coasts. This program included literature research and site-specific evaluations of existing physical, biological and socio-economic conditions. The following technical criteria were evaluated for potential sites:

- Geological resource suitability;
- Size and availability of site;
- Proximity to deep, ice free, sheltered water;
- Engineering feasibility;
- Presence or potential for environmental constraints such as species at risk, fish habitat and wetlands;
- Zoning, proximity to residential development and existing transportation networks;
- Economic diversity and sustainability; and,
- Presence or potential for unique heritage resources.

Because aggregates are a high-bulk low-cost commodity, the cost of transportation can easily exceed the price of the aggregate. So, for a marine quarry that requires considerably more capital than a land-based quarry to be profitable, the aggregate source must be located immediately adjacent to deep water and capable of being transported to the ship by conveyor. If trucks or rail are required to transport aggregate from the quarry to the wharf, the project would be uneconomical. Using these technical criteria, no other suitable alternative sites were found during the course of the exploration and reconnaissance program.

Insofar as no other economically viable sites were identified, the key VC affected by an alternate location would be Local Economy, Land and Resource Use. Alternate Project sites would presumably also impact other VCs related to the natural and human environment.

The key technical criteria which led to the selection of the Black Point Quarry Project site are:

- Availability of high quality, large tonnage, fine-to-medium grained, homogenous granite that meets or exceeds all of the necessary physical and chemical requirements to produce Class-A construction aggregate;

- Deep (>14 m), sheltered, ice-free bay for the location of the marine terminal to enable shipping of processed aggregate rather than trucking products through populated areas;
- Minimal to no overburden on the Project site, reducing development costs and limiting the potential for sedimentation during construction and operation;
- Proximity to well-traveled international shipping lanes with existing logistical support, such as pilot tugs; and,
- Appropriate zoning with no fundamental environmental or regulatory constraints, based on a preliminary review.

With Black Point, Guysborough Co. as the only technical and economically feasible location for the granite quarry, the following sections describe and evaluate alternative methods for undertaking the Black Point Quarry Project with respect to location and construction of the marine terminal and operational design aspects of the quarry.

#### **4.4 Rock Extraction Method**

Technical criteria to determine the feasibility of alternate extraction methods include simple practicality. Drilling and blasting is the proposed approach for material extraction from the Black Point Quarry. Alternative mechanical methods of rock extraction (e.g., ripping) are not practical or feasible due to the extremely hard and dense characteristics of the granite. Therefore, there are no feasible alternatives to drilling and blasting as a means of extracting this material. The VCs impacted by the alternatives rock extraction methods would be similar in both cases: both methods would result in noise and particulate emissions to air.

The differences in these methods relative to noise and particulate emissions are that ripping involves the use of heavy equipment with hardened metal teeth that essentially scrapes into the rock from above and along the front wall face. The noise created during ripping would be extreme due to the fact that granite ripping would be a slow process and continuous, requiring multiple machines to generate the amount of material needed to feed the process. The ripping process also would be a continuous source of dust emissions. In the case of drilling and blasting, the drilling process does not generate noise at such levels and the drill rigs include equipment to collect or reduce dust generated by drilling. Blasting is a very short duration event that is capable of generating ample amounts of stone to supply the plant; blasts only occur a few days a week at the most. Ultimately, the Black Point operation would not be economically feasible without the use of drilling and blasting.

#### **4.5 Development and Transportation**

Alternative site design and transportation methods/routes considered for the Project include:

- Development of a rock face open pit and progression in a southerly direction with transport of blasted rock to the processing area via large truck or conveyor system; and,
- Development of a glory hole open pit (from the top down) with transport of blasted rock to the processing area via a conveyor system with a tunnel.

Technical criteria to determine the feasibility of alternate site design and transportation options include worker and equipment safety, economics and practicality. The primary VC affected by

alternate site design and transportation options is Local Economy, Land and Resource Use. Due to worker safety concerns, operational issues and geotechnical considerations, the glory hole alternative consisting of a near vertical ore pass and underground horizontal portals was deemed not technically feasible. This option is also considerably more costly and so is not economically feasible when compared to the rock face approach.

The technical and safety challenges of the glory hole approach relate to the fact that all the stone produced would be dropped into a vertical shaft to a stockpile at the base of the hill. Rocks will frequently jam within the shaft, requiring blasting or other methods to free the blockage. The risk of injury or death to employees due to accidents involving workers trying to remove blockages as well as operating at the feed point and bottom stockpile area is not acceptable to Vulcan. The glory hole method would also generate higher levels of dust emissions and noise due to the fracturing created by the rock falling through the glory hole and then impacting the rock in the lower stockpile. The rock movement would also displace large volumes of air that would make it difficult to control the dust emitted from the operation.

In contrast, the use of haul trucks and conveyors for material transfer is well established, well understood, and much easier to manage. The methods for controlling dust emissions are effective and easy to implement, and the equipment can be safely operated by trained personnel.

While there are existing bulk terminals in the Strait of Canso, all are too far from the proposed quarry to be of economic use. The cost to transport a tonne of aggregate by truck is about \$0.15/km therefore, transporting material 50 km or so to the Strait would cost over \$7.50/tonne, essentially doubling the cost of the aggregate. In addition, transport of aggregate to the Strait would require high frequency truck traffic through several communities, which would likely raise significant concerns from local residents and add a cost burden for road repairs to the municipality. Other negative factors associated with off-site truck transport include the impact of heavy truck traffic on road durability as well as the potential for vehicle accidents due to the increase in heavy vehicle traffic on local roads. Another major factor affecting the economics of overland transport is the limitations of truck transport imposed by winter conditions including icy roads and snow storms.

#### **4.6 Marine Terminal Locations**

The Proponent has considered alternate locations for the marine terminal. Technical criteria to determine the feasibility of alternate marine terminal locations consist primarily of navigational and operational safety considerations. The primary VCs affected by alternate terminal locations are Marine Species and Habitat and Commercial Fisheries and Aquaculture, although for the most part, different marine terminal locations affect these VCs in much the same way.

Based on feedback from local fishermen, the terminal should be located as far west as possible to increase the sheltering effect from wind and strong currents off Black Point. However, this location is not practical since the bathymetric profile to nearshore area is too shallow (15-20 m vs 25-30 m at the preferred location). The originally proposed terminal site and the proposed range of alternative sites are presented in **Figure 4.0-1**. The selected alternative is the easternmost location. Following multiple meetings and discussions with the local fishermen, the selected location of the marine terminal is the preferred location to minimize impacts to fishing areas.



N:\Markham\Project Files\2014\210.05913\_Blackpoint\3.Data & Analysis\2.GIS\1.MXD\3.WRK\G210\_05913\_AltMarine Terminals.mxd

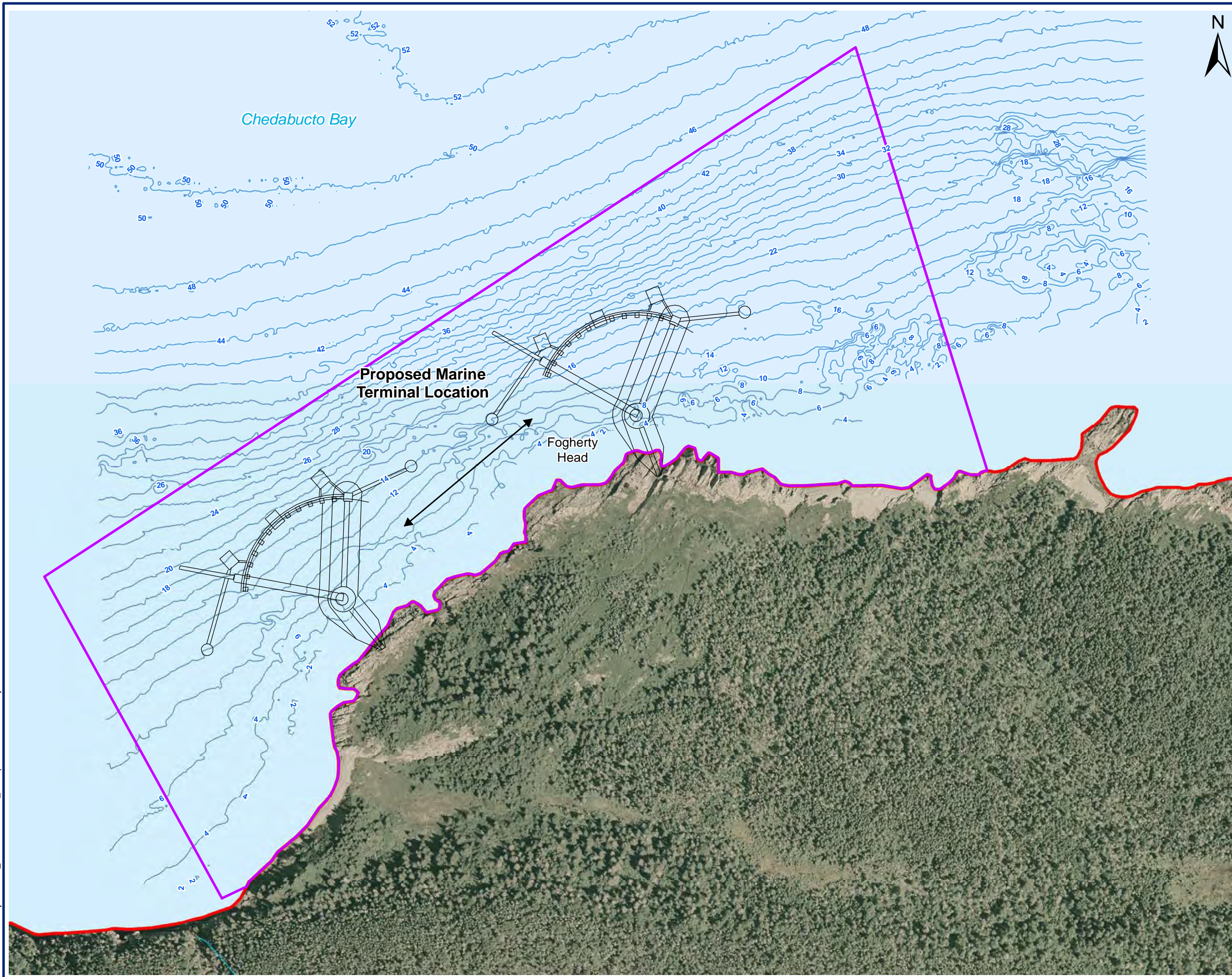

- LEGEND**
- Property Boundary
  - Crown Lease Land
  - Waterbody
  - Watercourse
  - Bathymetry (2m)



SCALE: 1:3,000  
WHEN PLOTTED CORRECTLY AT 11 x 17  
NAD 1983 UTM Zone 20N

**NOTES**  
This map is for conceptual purposes only and should not be used for navigational purposes.  
Basedata: Nova Scotia Natural Resources, downloaded, June 2014; Orthoimagery from GeoNOVA, 2007.

## MORIEN RESOURCES AND VULCAN MATERIALS

BLACK POINT QUARRY

ALTERNATIVE MARINE TERMINAL LOCATIONS

January 13, 2015	Rev <b>1.0</b>	Figure No.
Project No. 210.05913.00000		<b>4.0-1</b>





#### 4.7 Marine Terminal Construction Methods

Alternative construction methods for the marine terminal were investigated in order to reduce disruption to marine habitats and minimize costs. Technical criteria to determine the feasibility of alternate marine terminal construction methods consist of constructability, operational safety, operational performance and economic feasibility. The primary VC affected by alternate terminal construction methods is Marine Species and Habitat.

Two approaches to wharf construction were considered: the rubble mound approach and the concrete caisson approach. The rubble mound approach uses rock generated on site to form a continuous base upon which a wharf is constructed. In contrast, the caisson approach uses separate steel or concrete box-like forms (the caissons) to form pillars that support the wharf. Neither method requires in-water blasting or dredging although the caisson approach requires percussion (pounding) to install foundations into the seabed.

The rubble mound has a simpler design and is less expensive to design and build, and thus more cost effective. In addition, it permits the secure storage of any potentially acid-generating rock that may be present once the lower platform has been levelled for plant construction. The underwater storage of potentially acid-generating rock prevents acid formation and is a preferred management option for this material, should this be encountered during site construction.

The rubble mound is potentially more stable in rough weather and has lower maintenance costs over the long term. Most importantly, it is considerably more operationally efficient, since it allows for vehicular traffic and access to support maintenance of the ship mooring points. The caisson approach does not allow for vehicles and so maintenance would be conducted by boat, which is more expensive and potentially more dangerous.

The rubble mound typically occupies more of the seabed than the caissons and so it potentially affects more marine seabed habitat. Caissons also occupy seabed (to a lesser degree) but the wharf connecting the caisson would shade the seafloor, negatively affecting habitat quality and use. The rubble mound in time is expected to act as lobster habitat where the caisson method would not have a similar benefit.

Given the advantages of the rubble mound approach, in terms of constructability, operational safety, operational performance and economic feasibility, this design is chosen over the caisson approach. We underline that this approach will be used to construct the wharf beginning at the shore and extending to the ship mooring infrastructure. For mooring, ships will be attached to three mooring caissons as shown on **Figure 4.0-2**.



AREA OF IMPACT AT SEA FLOOR	
RUBBLE MOUND	7916m <sup>2</sup>
BREASTING CAISSONS (3)	1120m <sup>2</sup>
MOORING DOLPHIN (2)	1050m <sup>2</sup>
SLEWING RAIL AND PIER	992m <sup>2</sup>

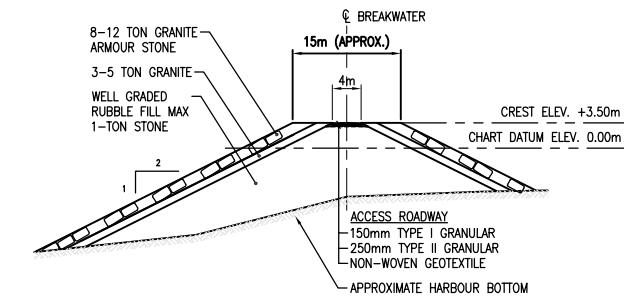

**A SECTION - TYPICAL RUBBLE MOUND**  
 S002 SCALE: 1:500  
 1:500

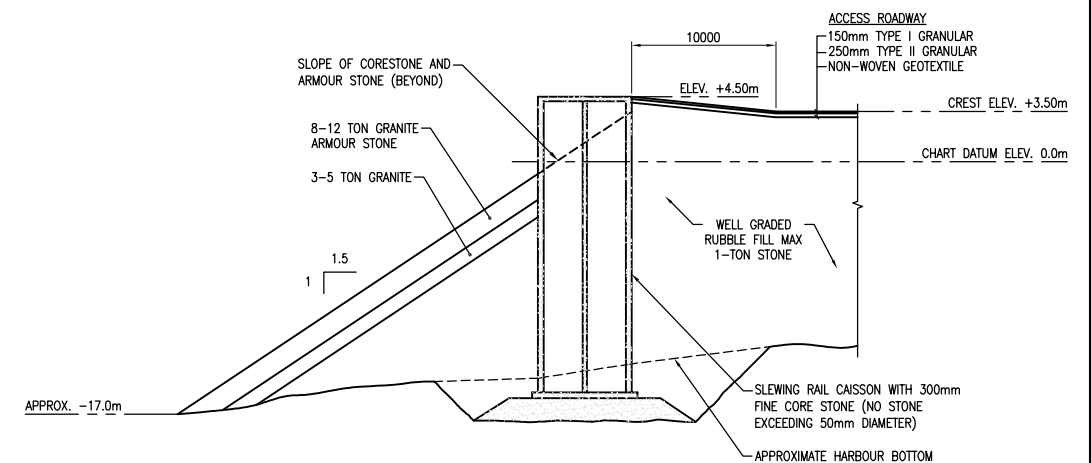

**B SECTION - RUBBLE MOUND AT CAISSON**  
 S002 SCALE: 1:250  
 1:250

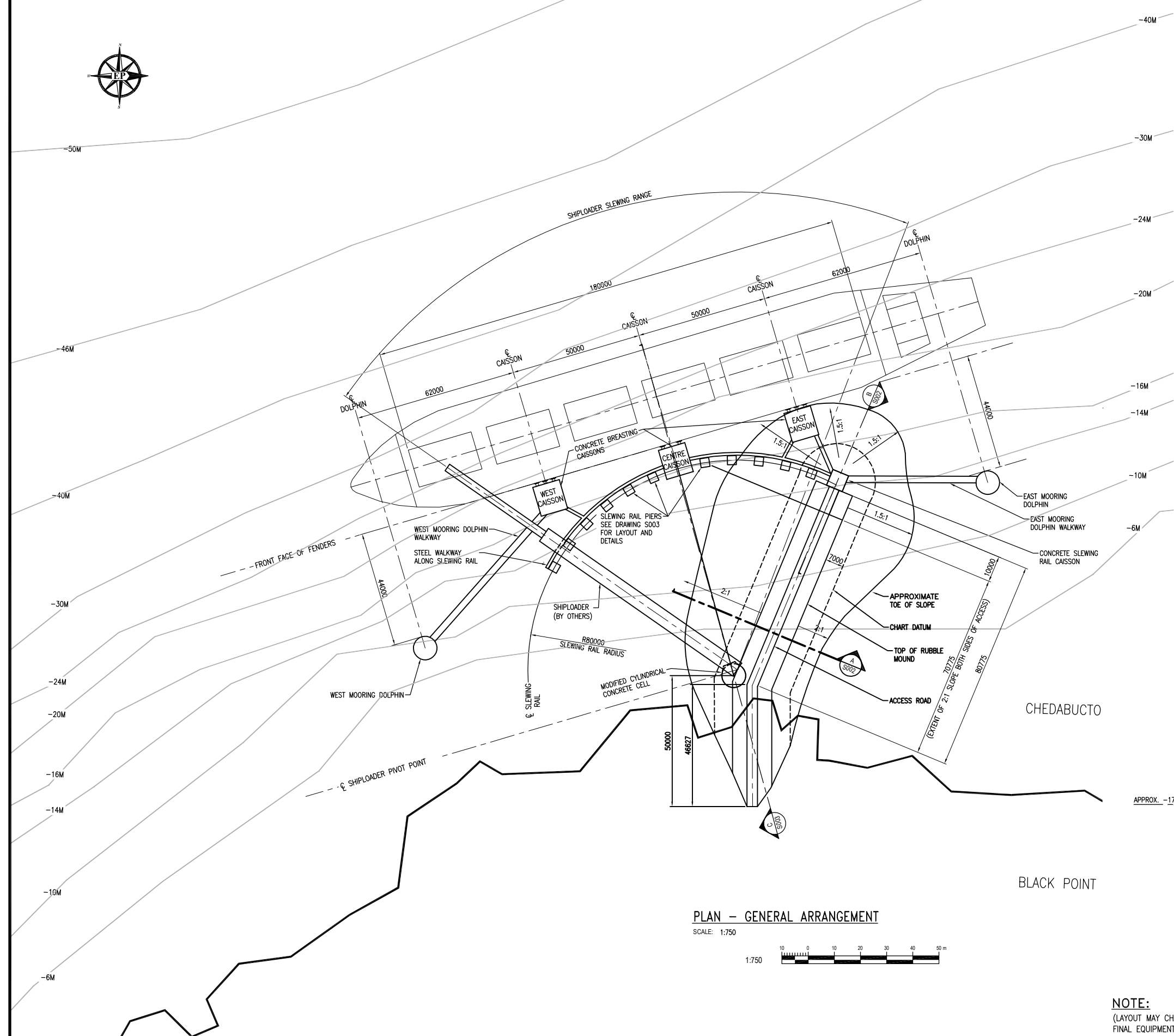

**PLAN - GENERAL ARRANGEMENT**  
 SCALE: 1:750

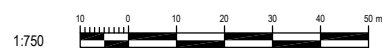

**NOTE:**  
 (LAYOUT MAY CHANGE TO SUIT FIELD CONDITIONS,  
 FINAL EQUIPMENT SELECTION, ETC.)

	D				<b>TOLERANCES—UNLESS NOTED</b> FRACTIONAL: ± 1/16" DECIMAL: ± 0.010" ANGLE: ± 0.1°		GENERAL ARRANGEMENT		STATE	NOVA SCOTIA	PLANT	BLACK POINT
	C						THIS DRAWING IN DESIGN AND DETAIL IS THE PROPERTY OF VULCAN MATERIALS COMPANY AND MUST BE RETURNED UPON DEMAND. THIS DRAWING MUST NOT BE COPIED, REPRODUCED, OR USED WITHOUT PERMISSION.	Figure 4.0-2: Marine Terminal Design		DATE 2014/09/08 DESIGNED BY OHS CHECKED BY BT DATE 2014/08/28	PROJ. NO. 55126 SCALE AS NOTED SHEET 2 OF 4	FILE SERIAL EASTPOINT
	A	2014/08/28	ISSUED FOR PERMIT	BT			Figure 4.0-2: Marine Terminal Design		SCALE AS NOTED SHEET 2 OF 4			
		DATE	REVISION	BY					S002			A

#### **4.8 Stockpile Locations**

Alternative stockpile locations were evaluated primarily to minimize costs and to limit potential impacts to wetlands. Technical criteria to determine the feasibility of alternate stockpile locations consist of operational performance and economic feasibility. The primary VC affected by alternate stockpile locations is Wetlands, since other VCs, such as Marine Species and Habitat and Commercial Fisheries and Aquaculture, would be equally affected (to a very limited degree) no matter which alternative was selected.

Stockpiles are proposed for the western portion of lower platform, adjacent to Chedabucto Bay and opposite the marine terminal. The alternative option places these stockpiles at the eastern side of the lower platform, adjacent to Chedabucto Bay and within 50 m of Wetland 2. In both alternatives, several wetlands would be lost (e.g., WLs 3, 4, 5 and 6 on **Figure 6.4-2**) but with the second alternative, Wetland 2 is potentially exposed to runoff from the stockpiles. More importantly, this location requires a complete reconfiguration of processing plant and a much longer conveyor system to deliver aggregate to the marine terminal. The preferred location is both operationally and economically more practical, and has the added benefit of lowering the risk of project-related impacts to a large wetland. The stockpile locations have also been selective to mitigate noise emissions from the processing operations thus reducing off-site noise impacts. The stockpiles will also provide a degree of visual screening for the processing plant.

#### **4.9 Waste Management Facilities**

There are two types of waste management facilities: a wastewater treatment facility to manage septic waste from site workers, and the berms that will control drainage from the piles of crusher fines (consisting of finely broken rock) generated after washing the crushed aggregate.

With respect to septic waste water treatment systems, technical criteria used to determine the feasibility of different systems include operational performance and, to a lesser degree, economic feasibility. The primary VCs affected by alternate wastewater treatment systems are Groundwater Resources and Marine and Surface Water Resources.

Alternative wastewater treatment facilities were considered but none are as practical, efficient or cost effective as a simple collection tank with follow up transport and treatment at the Canso municipal waste water treatment facility. Alternatives include a conventional septic tank and leach field, above ground systems that use imported, mounded soil to treat waste effluent, the use non-conventional systems such as multiple rotating biological contactors, peat-based treatment systems, constructed wetlands, and recirculating media filters such as sand filtration. Conventional on-site treatment for the 50-60 full time staff would require a large leach field with adequate soil depth above bedrock. These conditions do not exist near the administrative buildings where the washrooms will be located. Non-conventional systems are more expensive to purchase, install and operate, and typically do not perform well, especially in winter. Ultimately, a gravity fed collection tank with off-site treatment was selected as the preferred option, at least initially. The use of a conventional, raised bed system will be investigated once the plant area is accessible. Existing soil thickness and texture will be investigated to determine if the construction of a raised bed treatment system is practical.

Alternate locations for the crusher fines have been considered. The technical criteria used to determine the preferred location includes handling costs (distance from site-of-generation combined with the number of times the crusher fines are moved, once generated), available



surface area, and pre-development habitat type. The VCs affected by crusher fines storage location include: Groundwater Resources, Marine and Surface Water Resources, Terrestrial Ecosystems, Habitat & Vegetation, Wetlands, and Terrestrial Wildlife.

Initially, crusher fines storage was proposed for areas outside of the quarry (**Figure 4.0-3**) but this was later determined to be unnecessarily distant from where this crushed rock will be generated. All waste rock will now be stored within the quarry. This has the additional advantage of ensuring the crusher fines can never be lost to the marine environment.

The storage of the fines inside the quarry also eliminates the potential for storm water runoff releases to the environment and the discharge of fines to surface waters because the quarry stormwater will be contained in the pit. The fines stock piles also can be sources of fugitive dust emissions and so locating them inside the quarry will help to contain these emissions.



**Figure 4.0-3:  
Alternative Crusher Fines Storage Areas (Orange)**

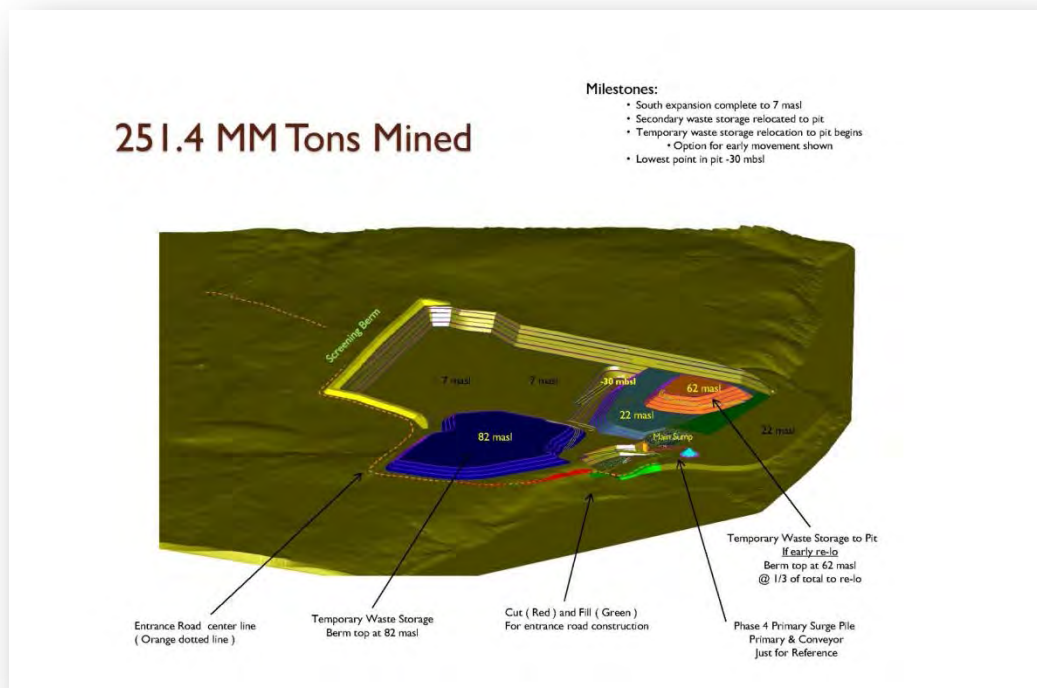

**Figure 4.0-4:  
Preferred Crusher Fines Storage Areas (Orange and Blue)**

#### 4.10 Electrical Supply

Significant and reliable electrical power will be required for buildings and the operation of equipment (pumps, conveyors, crushers, screens, and ship loading). The total electrical power demand for the quarry is estimated to be between 10,000 and 12,000 horsepower (i.e., 5.0-6.0 MW), mostly for operation of large electrical motors associated with the processing plant equipment.

Alternative electrical supplies considered for this project include a tie-in to the existing high voltage Nova Scotia Power Inc. electrical transmission line that parallels the southern boundary of the Project site or the use of multiple on-site generators. Technical criteria used to determine the preferred option are operational cost, operational performance, safety considerations, and project emissions (both GHGs and noise).

Over the long term, electricity produced by generators is more expensive than conventional sources due to fuel costs, generator inefficiencies, the need for replacement lubricating oils, and the man-hours dedicated to on-going maintenance. The transport to site, storage and use of fuel for generators increase spill risks to surface and groundwater, and increase the risk of fire or explosion at the site. Project emissions from generators are significantly higher, both in terms of GHGs and noise, when compared to power generators at larger, more efficient power

stations. Given these factors, the preferred option is to tie in to the existing transmission line, rather than use permanent generators to power the site<sup>5</sup>.

#### **4.11 The Preferred Approach**

Based on the relative consideration of technical and economic feasibility, likely environmental effects, overall social acceptability, the preferred approach consists of:

1. A granite aggregate quarry located on zoned industrial property in the MODG, near Black Point.
2. Quarrying methods that employ drilling and blasting.
3. Development of the quarry from the north to south, rather than from the top down.
4. Shipping from a newly constructed marine terminal, rather than trucking to an existing marine facility.
5. A largely rubble mound marine terminal located on the western end of the coastal property.
6. Stockpiles located on the western side of the property, facing the marine terminal
7. Off-site treatment of septic waste during initial project phases, possibly followed by the construction of conventional, raised bed septic waste treatment facility.
8. Crusher fines storage area located with respect to minimizing impacts to wetlands.
9. Crusher fines storage within the quarry, rather than exterior to the pit boundaries.
10. Tie in to a nearby electrical transmission line rather than using permanent on-site generators.

Table 4.1 summarizes the alternative means analysis for each component considered above and presents the preferred option selected for the Project.

---

<sup>5</sup> Temporary generators will be used during initial project construction phases to provide electricity to administrative buildings while the electrical tie in is being constructed.

**Table 4.1  
 Summary of the Alternative Means of Undertaking the Project**

Project Component	Alternative Means	Technical Feasibility	Economic Feasibility	Environmental Effects	Preferred Option
Quarry Location	Black Point Site	Technically Feasible	Economically Feasible	A number of environmental effects are associated with any quarry development; no significant residual environmental effects are anticipated at the Black Point site.	Yes
	Other Nova Scotia Sites	Not Technically Feasible considering the range and specificity of the geographical and resource requirements	Not Economically Feasible based on the Proponent's analysis and given the high-bulk low-cost nature of the aggregate resource	Not assessed since no feasible alternative site was identified	No
Rock Extraction Method	Drilling and Blasting	Technically Feasible	Economically Feasible	Environmental effects are similar in both alternatives: will result in noise and dust impacts. Drilling and blasting has less of an impact due to shorter duration and more established control methods.	Yes
	Ripping	Not Technically Feasible considering the hardness and density of the granite resource	Not Economically Feasible	Environmental effects are similar in both alternatives: will result in noise and dust impacts. Ripping would be more impactful due to more continuous and less controllable dust emissions.	No
Development and Transportation	Rock Face Open Pit	Technically Feasible	Economically Feasible	Environmental effects are largely similar under both mining options	Yes
	Glory Hole Open Pit	Not Technically Feasible primarily due to worker safety considerations	Economically Feasible but additional infrastructure would significantly increase production costs	Potential social (human health) effects are greater in the glory hole scenario due to increased worker exposure to accidents and malfunctions	No



	Transport via Ship from Dedicated Terminal	Technically Feasible	Economically Feasible	Environmental effects relate primarily to Local Economy, Land and Resource Use; shipping related effects are similar in both scenarios.	Yes
	Truck Transport to an Existing Terminal Followed by Transport via Ship (e.g., Auld's Cove)	Technically Feasible	Not Economically Feasible due to truck transportation costs, which would eliminate profitability	Significantly more environmental and economic impacts due to truck traffic through rural and residential areas. Increased air and noise emissions in this scenario.	No
Marine Terminal Location	Eastern Location	Technically Feasible	Economically Feasible	Environmental effects are similar under both alternatives. The VCs Marine Species and Habitat and Commercial Fisheries and Aquaculture would be affected in a similar manner at both terminal locations.	Yes
	Western Location	Not Technically Feasible due to shallow water depths	Economically Feasible	As above; this location is also slightly more sheltered from winds originating to the northeast.	No
Marine Terminal Construction	Rubble Mound Wharf	Technically Feasible and permits the secure storage of acid generating rock; more operationally efficient since it permits vehicular access to ship mooring points for maintenance	Economically Feasible; less expensive to design, build and maintain	Both approaches would affect Marine Species/Habitat and Commercial Fisheries to approximately the same degree. Rubble Mound Wharf occupies more seafloor than the Concrete Caisson Wharf but the rubble would eventually act as lobster habitat.	Yes
	Concrete Caisson Wharf	Technically Feasible but less stable in severe weather; more dangerous to maintain since boat access would be needed.	Economically Feasible	Concrete Caisson Wharf occupies less seafloor than the Rubble Mound Wharf but would shade the seafloor, negatively affecting habitat quality and use.	No
Stockpile Locations	Western End Opposite the Marine Terminal	Technically Feasible	Economically Feasible: this location is both operationally and	In both alternatives, several wetlands would be lost. This alternative provides effective noise and visual mitigation.	Yes

			economically more practical.		
	Eastern End near Wetland 2	Technically Feasible although it greatly increases the complexity of operation and may introduce occupational health and safety risks	Not Economically Feasible: this location requires a complete reconfiguration of processing plant and a much longer conveyor system to deliver aggregate to the marine terminal.	In addition to wetland loss, Wetland 2 is potentially exposed to runoff from the stockpiles in this alternative	No
	Collection tank for septic wastes with transport and treatment at the Canso municipal waste water treatment facility	Technically Feasible and practical	Economically Feasible and cost effective	Minimal impact to Groundwater Resources and Marine and Surface Water Resources.	Yes
Waste Management	Other septic treatment systems: conventional septic tank and leach field, raised bed systems, rotating biological contactors, peat-based treatment systems, constructed wetlands, and recirculating sand filtration	Not Technically Feasible due to lack of soil cover (conventional leach field): Technically Feasible but poor operational records when applied to operations at this scale (non-conventional treatment systems).	Economically more expensive to design, purchase, operate and maintain	Varying long term impacts can be expected to Groundwater Resources and Marine and Surface Water Resources through treated effluent discharge.	No
	"Crusher fines" storage outside of the quarry	Technically Feasible	Economically Feasible but more expensive considering the increased transport distance to the storage site and the greater number of times the materials would be handled	Increased risk of accidental discharge with potential negative effects on Marine and Surface Water Resources, Terrestrial Ecosystems, Habitat & Vegetation, Wetlands, and Terrestrial Wildlife. Similar anticipated effects (i.e., minimal) on Groundwater Resources in both alternatives. Increased handling and transport increases impacts to air quality.	No

	"Crusher fines" storage within the quarry	Technically Feasible	Economically Feasible	No risk of accidental discharge to the environment (potentially affecting Marine and Surface Water Resources, Terrestrial Ecosystems, Habitat & Vegetation, Wetlands, and Terrestrial Wildlife)	Yes
Electrical Supply	Tie-in to the existing electrical transmission line	Technically Feasible	Economically Feasible; more expensive over the short term but costs are recovered over the longer term.	Environmental effects associated with habitat and vegetation loss within the right of way are minimized by using the same right of way for the access road.	Yes
	Use of multiple on-site generators	Technically Feasible	Economically Feasible but more expensive over the long term due to fuel, lubricant and transport costs, as well as maintenance and operating costs	Increased risks of fire and fuel spills given the generators' fuel requirements; increased impacts to ambient noise levels; increased GHG emissions	No

## **5.0 ENVIRONMENTAL EFFECTS ASSESSMENT METHODOLOGY**

To establish the appropriate scope of an environmental assessment, it is standard practice to limit the assessment to those environmental components that are valued or of interest for ecological, scientific, cultural, regulatory and/or economic reasons. In keeping with the terminology used in the federal EIS Guidelines issued for the Black Point Quarry Project, these aspects are referred to as Valued Components (VCs). As described below, identification of the specific VCs considers feedback from the public, regulatory agencies, First Nations communities and other stakeholders. The EIS Guidelines (CEA Agency 2014) issued for the Black Point Quarry Project describe the type of Project information required, the scope of the environmental assessment and the factors to be considered during the assessment.

### **5.1 Overview**

The method used to predict the effects of the Black Point Quarry Project was developed to meet the requirements of the EIS Guidelines (CEA Agency 2014). These Guidelines include requirements of both the federal and provincial governments. In addition, the methodology is intended to incorporate:

1. Subjects, concerns and issues raised by the Mi'kmaq, fishermen and the public at large over the course of the project;
2. The environmental and social aspects of interest to the scientific and regulator communities; and
3. Legislative and regulatory requirements that apply to this type of development.

The following sections describe the methodology used to derive:

- The spatial and temporal boundaries of the study areas;
- The origin and scope of the VCs that will be evaluated to assess project impacts;
- The probable interactions between the Project and the VCs;
- The potential environmental effects of the Project on the VCs;
- The mitigation measures that will be used to eliminate, reduce or control the potential environmental effects; and
- The residual effects that remain after mitigation measures are applied, combined with a determination of their significance.

The goal of applying a defined environmental assessment methodology is to carefully examine the Project and related activities to ensure they will not cause “serious or irreversible harm to the environment, especially with respect to environmental functions and integrity, system tolerance and resilience, and/or the human health of current or future generations” (CEA Agency 2014).

### **5.2 Application of the Precautionary Approach**

The joint federal-provincial EIS Guidelines require that the proponent examine the proposed project infrastructure and activities and demonstrate the project has been planned in a “precautionary manner in order to ensure that they would not cause serious or irreversible damage to the environment...” (CEA Agency 2014). To demonstrate the precautionary approach, this environmental assessment:



1. Describes and justifies the assumptions made about the effects of the Project, and the approaches to minimize these effects;
2. Shows that priority will be given to strategies that avoid the creation of adverse effects;
3. Describes contingency plans that explicitly address accidents and malfunctions; and
4. Outlines follow-up and monitoring programs to verify impact predictions.

### **5.3 Valued Components Selection**

The EIS Guidelines define Valued Components (VCs) as “attributes associated with the project that have been identified to be of concern by the proponent, government agencies, Aboriginal peoples and/or the public. The value of a component not only relates to its role in the ecosystem, but also to the value placed on it by humans” (CEA Agency 2014).

An internal issues-scoping exercise was undertaken to identify the VCs of both general and project-specific interest. For the Black Point Quarry Project, provisional VCs (Table 5-1) were identified through:

- Discussions regarding potential environmental concerns with the CEA Agency, DFO, Environment Canada, Transport Canada, NSE and NSDNR;
- A review of the EIS Guidelines prepared for this project, especially those subjects listed in section 9.1 of the Guidelines (CEA Agency 2014);
- A review of applicable provincial and federal regulation, including an appraisal of species of conservation concern and Species at Risk. The Guidelines specifically require consideration of the factors listed in subsection 19(1) of *CEAA 2012*, as well as those presented section 79 of the *Species at Risk Act* (CEA Agency 2014);
- Discussions with government scientific authorities (e.g., hydrogeologists, Species at Risk specialists, wetland experts, etc.);
- Previous environmental studies conducted on site by AMEC, Davis MacIntyre Associates, Mi'kma'ki All Points Services and others;
- Comments raised a public open house meeting held by Morien in Queensport on April 22, 2014 and subsequent comments received as part of the ongoing public consultation process as noted in Section 11;
- Comments raised during face-to-face meetings with nearby residents, fishermen and other stakeholders, including the Mi'kmaq (Section 11);
- A review of information submitted in support of nearby and similar environmental assessments; and
- The professional experience of the Project team.

**Table 5.1:  
 List of Provisional Valued Components**

<b>Environmental Aspect</b>	<b>Provisional VC</b>
Atmospheric Resources	Air Quality & Climate Change
	Noise
	Ambient Light
Biophysical Resources	Geology, Soil & Sediment
	Groundwater Resources
	Marine and Surface Water Resources
	Terrestrial Ecosystems, Habitat & Vegetation
	Wetlands
	Terrestrial Wildlife
	Freshwater Species and Habitat
	Marine Species and Habitat
	Species at Risk
	Socio Economic and Heritage Resources
Tourism and Recreation	
Commercial Fisheries and Aquaculture	
Archaeological and Heritage Resources	
Aboriginal Land and Resource Use	

#### 5.4 Likely Project-Environment Interactions

Most interactions between the Project and the surrounding environment are fairly obvious and can be logically expected once the project activities and infrastructure have been described. In many instances, project-environment interactions are *direct*. For example, the quarry will remove granite rock from beneath certain existing wetlands: these wetlands will inevitably be lost. Other interactions may be *indirect* and are less obvious. For example, if down slope wetlands outside the property boundary are fed by surface runoff falling on the granite, then removal of the granite rock may reduce runoff and so negatively affect these wetlands.

In order to determine the potential direct and indirect interactions, the Project team (a) reviewed the anticipated activities required to construct, operate and decommission the Project; (b) considered the potential direct and indirect effects from these activities, (c) identified likely pathways between the Project and the receiving environment, and (d) assessed the probable Project effects on the environment through these pathways.

A “pathway” is a link between a Project activity and the environment. It is the means or route through which the Project may positively or negatively affect one or more environmental and/or social receptors. On occasion, a VC can act as both a receptor and a pathway. For example, surface water (the receptor) may be affected by the Project if erosion is not properly controlled during construction. At the same time, surface water may act as a pathway if poor surface water quality negatively affects aquatic organisms that depend on that water.

This linkage between the source, the pathway and the receptor is the core of the environmental assessment process. Once the linkage has been established, the assessment process can

predict the magnitude and duration of impacts, then evaluate mitigation measures to limit or eliminate those impacts. These steps are described in detail for each VC in Section 7.0.

Potential Project interactions with the provisional VCs are presented in Table 5-2. Table 5-3 summarizes the rationale for the selection of each VC, and also includes a description of the potential for certain VCs to act as pathways as well as receptors.

**Table 5.2:  
 Potential Project Interactions with Valued Components (VCs)**

Project Activity	Geology, Soils and Sediment	Groundwater Resources	Surface Water Resources	Climate Change	Air Quality	Noise	Ambient Light	Terrestrial Habitat and Vegetation	Wetlands	Terrestrial Fauna	Migratory Birds	Freshwater Species and Habitat	Marine Water Quality	Marine Species and Habitat	Species at Risk	Economy, Land & Resources	Commercial Fisheries and Aquaculture	Marine Safety and Navigation	Visual Landscape	Tourism and Recreation	Aboriginal Lands and Resource Use	Archaeological Resources
<b>Construction Phase</b>																						
Clearing, grubbing and grading in preparation of construction	<input checked="" type="checkbox"/>	<input checked="" type="checkbox"/>	<input checked="" type="checkbox"/>	<input checked="" type="checkbox"/>	<input checked="" type="checkbox"/>	<input checked="" type="checkbox"/>		<input checked="" type="checkbox"/>	<input checked="" type="checkbox"/>	<input checked="" type="checkbox"/>	<input checked="" type="checkbox"/>	<input checked="" type="checkbox"/>	<input checked="" type="checkbox"/>		<input checked="" type="checkbox"/>	<input checked="" type="checkbox"/>			<input checked="" type="checkbox"/>	<input checked="" type="checkbox"/>	<input checked="" type="checkbox"/>	<input checked="" type="checkbox"/>
Operation of construction machinery				<input checked="" type="checkbox"/>	<input checked="" type="checkbox"/>	<input checked="" type="checkbox"/>					<input checked="" type="checkbox"/>											
Blasting and excavation in preparation of construction	<input checked="" type="checkbox"/>	<input checked="" type="checkbox"/>	<input checked="" type="checkbox"/>		<input checked="" type="checkbox"/>	<input checked="" type="checkbox"/>				<input checked="" type="checkbox"/>	<input checked="" type="checkbox"/>			<input checked="" type="checkbox"/>	<input checked="" type="checkbox"/>	<input checked="" type="checkbox"/>			<input checked="" type="checkbox"/>	<input checked="" type="checkbox"/>		
Processing plant and associated infrastructure construction	<input checked="" type="checkbox"/>		<input checked="" type="checkbox"/>	<input checked="" type="checkbox"/>		<input checked="" type="checkbox"/>	<input checked="" type="checkbox"/>	<input checked="" type="checkbox"/>	<input checked="" type="checkbox"/>	<input checked="" type="checkbox"/>	<input checked="" type="checkbox"/>				<input checked="" type="checkbox"/>	<input checked="" type="checkbox"/>						
Marine terminal construction (rubble mound)	<input checked="" type="checkbox"/>			<input checked="" type="checkbox"/>		<input checked="" type="checkbox"/>	<input checked="" type="checkbox"/>				<input checked="" type="checkbox"/>		<input checked="" type="checkbox"/>	<input checked="" type="checkbox"/>	<input checked="" type="checkbox"/>	<input checked="" type="checkbox"/>	<input checked="" type="checkbox"/>	<input checked="" type="checkbox"/>	<input checked="" type="checkbox"/>		<input checked="" type="checkbox"/>	
Marine vessel operation in support of terminal construction				<input checked="" type="checkbox"/>		<input checked="" type="checkbox"/>					<input checked="" type="checkbox"/>			<input checked="" type="checkbox"/>	<input checked="" type="checkbox"/>		<input checked="" type="checkbox"/>	<input checked="" type="checkbox"/>				
Watercourse and wetland alteration	<input checked="" type="checkbox"/>	<input checked="" type="checkbox"/>							<input checked="" type="checkbox"/>	<input checked="" type="checkbox"/>	<input checked="" type="checkbox"/>	<input checked="" type="checkbox"/>										
Stormwater management	<input checked="" type="checkbox"/>	<input checked="" type="checkbox"/>																				
Local employment and expenditure																<input checked="" type="checkbox"/>				<input checked="" type="checkbox"/>	<input checked="" type="checkbox"/>	
<b>Operation / Decommissioning Phase</b>																						
Use of the access road			<input checked="" type="checkbox"/>		<input checked="" type="checkbox"/>							<input checked="" type="checkbox"/>			<input checked="" type="checkbox"/>							
Operation/removal of quarrying equipment and machinery				<input checked="" type="checkbox"/>	<input checked="" type="checkbox"/>	<input checked="" type="checkbox"/>					<input checked="" type="checkbox"/>											



Project Activity	Geology, Soils and Sediment	Groundwater Resources	Surface Water Resources	Climate Change	Air Quality	Noise	Ambient Light	Terrestrial Habitat and Vegetation	Wetlands	Terrestrial Fauna	Migratory Birds	Freshwater Species and Habitat	Marine Water Quality	Marine Species and Habitat	Species at Risk	Economy, Land & Resources	Commercial Fisheries and Aquaculture	Marine Safety and Navigation	Visual Landscape	Tourism and Recreation	Aboriginal Lands and Resource Use	Archaeological Resources
Blasting, crushing, screening and washing		<input checked="" type="checkbox"/>	<input checked="" type="checkbox"/>	<input checked="" type="checkbox"/>	<input checked="" type="checkbox"/>	<input checked="" type="checkbox"/>					<input checked="" type="checkbox"/>											
Watercourse and wetland alteration	<input checked="" type="checkbox"/>		<input checked="" type="checkbox"/>						<input checked="" type="checkbox"/>	<input checked="" type="checkbox"/>	<input checked="" type="checkbox"/>	<input checked="" type="checkbox"/>										
Operation of stockpiles and load-out facility					<input checked="" type="checkbox"/>	<input checked="" type="checkbox"/>	<input checked="" type="checkbox"/>				<input checked="" type="checkbox"/>		<input checked="" type="checkbox"/>						<input checked="" type="checkbox"/>	<input checked="" type="checkbox"/>		
Stormwater and wash water management and use	<input checked="" type="checkbox"/>		<input checked="" type="checkbox"/>										<input checked="" type="checkbox"/>									
Marine vessel operations											<input checked="" type="checkbox"/>		<input checked="" type="checkbox"/>	<input checked="" type="checkbox"/>	<input checked="" type="checkbox"/>	<input checked="" type="checkbox"/>	<input checked="" type="checkbox"/>		<input checked="" type="checkbox"/>	<input checked="" type="checkbox"/>	<input checked="" type="checkbox"/>	
Waste water treatment system operation and discharge	<input checked="" type="checkbox"/>		<input checked="" type="checkbox"/>										<input checked="" type="checkbox"/>				<input checked="" type="checkbox"/>					
Local employment and expenditure																<input checked="" type="checkbox"/>					<input checked="" type="checkbox"/>	<input checked="" type="checkbox"/>
Accidents and Malfunctions																						
Fuel or other spills on land	<input checked="" type="checkbox"/>	<input checked="" type="checkbox"/>	<input checked="" type="checkbox"/>									<input checked="" type="checkbox"/>	<input checked="" type="checkbox"/>				<input checked="" type="checkbox"/>					
Fire on site or on ship					<input checked="" type="checkbox"/>																	
Marine collision and spills in the marine environment													<input checked="" type="checkbox"/>	<input checked="" type="checkbox"/>	<input checked="" type="checkbox"/>	<input checked="" type="checkbox"/>	<input checked="" type="checkbox"/>		<input checked="" type="checkbox"/>		<input checked="" type="checkbox"/>	<input checked="" type="checkbox"/>
Stormwater pond overflow																						
Unplanned explosive effect	<input checked="" type="checkbox"/>	<input checked="" type="checkbox"/>			<input checked="" type="checkbox"/>	<input checked="" type="checkbox"/>					<input checked="" type="checkbox"/>											

**Table 5.3:  
 Basis for Selection of VCs**

Environmental Category	Valued Component (VC)	Relevance to Environmental Features									Rationale for VC Selection (Interactions, Pathways and Relevance)
		Project - Environment Interaction	(D=Direct; P = as Pathway)	Local Requirement	Scientific Interest	Biophysical Context	Socio Economic	Human Health	Enjoyment of Life and Property	Cultural	
Biophysical Environment	Air Quality and Climate Change	D,P	<input checked="" type="checkbox"/>	<input checked="" type="checkbox"/>	<input checked="" type="checkbox"/>	<input checked="" type="checkbox"/>	<input checked="" type="checkbox"/>	<input checked="" type="checkbox"/>	<input checked="" type="checkbox"/>	<input checked="" type="checkbox"/>	<ul style="list-style-type: none"> <li>• Potential for negative effects to local air quality.</li> <li>• Potential for contributions to local and global climate change.</li> <li>• Pathway to potential impacts on flora, fauna, and human health.</li> </ul>
	Noise	D,P	<input checked="" type="checkbox"/>	<input checked="" type="checkbox"/>	<input checked="" type="checkbox"/>	<input checked="" type="checkbox"/>	<input checked="" type="checkbox"/>	<input checked="" type="checkbox"/>	<input checked="" type="checkbox"/>	<input checked="" type="checkbox"/>	<ul style="list-style-type: none"> <li>• Potential for changes to existing acoustic environment.</li> <li>• Potential pathway for impacts on fauna and human health.</li> </ul>
	Ambient Light	D, P					<input checked="" type="checkbox"/>	<input checked="" type="checkbox"/>	<input checked="" type="checkbox"/>	<input checked="" type="checkbox"/>	<ul style="list-style-type: none"> <li>• Potential for changes in the existing lighting conditions.</li> <li>• Potential pathway for impacts on fauna and human health.</li> </ul>
	Geology, Soil & Sediment Quality	D, P		<input checked="" type="checkbox"/>	<input checked="" type="checkbox"/>			<input checked="" type="checkbox"/>	<input checked="" type="checkbox"/>	<input checked="" type="checkbox"/>	<ul style="list-style-type: none"> <li>• Potential for generation of acid drainage from Halifax Formation bedrock.</li> <li>• Pathway to potential impacts on flora, fauna, and human health.</li> </ul>
	Groundwater Resources	D,P	<input checked="" type="checkbox"/>	<input checked="" type="checkbox"/>	<input checked="" type="checkbox"/>		<input checked="" type="checkbox"/>	<input checked="" type="checkbox"/>	<input checked="" type="checkbox"/>	<input checked="" type="checkbox"/>	<ul style="list-style-type: none"> <li>• Potential for negative effects on groundwater quality and quantity.</li> <li>• Potential for impacts on local water supply wells.</li> <li>• Pathway to potential impacts on human health.</li> </ul>
	Marine and Surface Water Resources	D,P	<input checked="" type="checkbox"/>	<input checked="" type="checkbox"/>	<input checked="" type="checkbox"/>	<input checked="" type="checkbox"/>		<input checked="" type="checkbox"/>	<input checked="" type="checkbox"/>	<input checked="" type="checkbox"/>	<ul style="list-style-type: none"> <li>• Potential marine water quality effects from acid generating rock, erosion during construction phase, stormwater discharges, accidental spills, and wastewater discharges.</li> <li>• Potential for siltation from erosion and stormwater discharges.</li> <li>• Pathway to potential impacts on fauna and human enjoyment of resources.</li> </ul>
	Terrestrial Species	D,P	<input checked="" type="checkbox"/>	<input checked="" type="checkbox"/>	<input checked="" type="checkbox"/>				<input checked="" type="checkbox"/>	<input checked="" type="checkbox"/>	<ul style="list-style-type: none"> <li>• Potential for terrestrial habitat removal and/or alteration.</li> </ul>

	and Habitat, including SAR									<ul style="list-style-type: none"> <li>• Potential for adverse effects on species resulting from changes in terrestrial habitat.</li> <li>• Potential for adverse effects on SAR as a result of direct impact or habitat changes.</li> <li>• Pathway to potential impacts on traditional land uses/ resource uses.</li> </ul>
	Freshwater Species and Habitat, including SAR	P	<input checked="" type="checkbox"/>	<input checked="" type="checkbox"/>	<input checked="" type="checkbox"/>		<input checked="" type="checkbox"/>			<ul style="list-style-type: none"> <li>• Pathway to potential impacts on Aboriginal, commercial, recreational fisheries.</li> </ul>
	Marine Species and Habitat, including SAR	D,P		<input checked="" type="checkbox"/>	<input checked="" type="checkbox"/>		<input checked="" type="checkbox"/>	<input checked="" type="checkbox"/>		<ul style="list-style-type: none"> <li>• Potential for 'severe harm' effect to fisheries productivity.</li> <li>• Potential for adverse effects on marine SAR as a result of direct impact or 'severe harm'.</li> <li>• Pathway to potential impacts on Aboriginal, commercial, recreational fisheries and Human Health.</li> </ul>
	Wetlands	D, P	<input checked="" type="checkbox"/>	<input checked="" type="checkbox"/>	<input checked="" type="checkbox"/>		<input checked="" type="checkbox"/>	<input checked="" type="checkbox"/>		<ul style="list-style-type: none"> <li>• Potential for direct loss and/or adverse effects on wetland extent and functions.</li> </ul>
Socio-Economic and Cultural Environment	Local Economy, Land and Resource Use	D			<input checked="" type="checkbox"/>	<input checked="" type="checkbox"/>	<input checked="" type="checkbox"/>	<input checked="" type="checkbox"/>	<input checked="" type="checkbox"/>	<ul style="list-style-type: none"> <li>• Short term employment opportunities during construction.</li> <li>• Long-term employment opportunities during operation.</li> <li>• Economic spin-off effects.</li> <li>• Potential to positively or negatively affect real estate values</li> <li>• Contributions to municipal tax base.</li> <li>• Pathway to potential impacts on traditional land uses/ resource uses.</li> </ul>
	Tourism and Recreation	D			<input checked="" type="checkbox"/>		<input checked="" type="checkbox"/>	<input checked="" type="checkbox"/>	<input checked="" type="checkbox"/>	<ul style="list-style-type: none"> <li>• Potential to negatively affect wilderness/nature oriented tourism.</li> <li>• Improved economics leading to improvement of tourism infrastructure</li> </ul>
	Commercial Fisheries and Aquaculture	D	<input checked="" type="checkbox"/>	<input checked="" type="checkbox"/>	<input checked="" type="checkbox"/>	<input checked="" type="checkbox"/>	<input checked="" type="checkbox"/>	<input checked="" type="checkbox"/>	<input checked="" type="checkbox"/>	<ul style="list-style-type: none"> <li>• Potential for displacement of fishermen to less productive areas</li> <li>• Potential for increased competition / lower harvests due to displacement</li> <li>• Potentially reduced harvest rates/ sales volumes as a consequence of adverse effects on resource.</li> </ul>
	Aboriginal Land and Resource Use	D	<input checked="" type="checkbox"/>		<input checked="" type="checkbox"/>		<input checked="" type="checkbox"/>	<input checked="" type="checkbox"/>	<input checked="" type="checkbox"/>	<ul style="list-style-type: none"> <li>• Potential for conflict with traditional land uses and land claims.</li> </ul>
	Archaeological & Heritage Resources	D	<input checked="" type="checkbox"/>				<input checked="" type="checkbox"/>	<input checked="" type="checkbox"/>	<input checked="" type="checkbox"/>	<ul style="list-style-type: none"> <li>• Potential for disturbance of archaeological sites.</li> </ul>

## 5.5 Project Boundaries

An important aspect of an environmental assessment is determining assessment boundaries that define the extent of anticipated effects. Project effects can be felt over different time periods (temporal boundaries), in different geographic areas (spatial boundaries) or can be limited by the nature of the effect (administrative and technical boundaries). Boundaries help focus the scope of the assessment to those zones that will logically experience actual project impacts.

### 5.5.1 Temporal Boundaries

Temporal boundaries represent the duration over which the Project activities interact with each VC. Since this may change depending on the VC, the duration of these interactions is described in each individual VC chapter. In general, the temporal boundaries are (a) the construction period, and (b) the operating life of the Project, through to decommissioning and reclamation.

Overall project timelines are based on an expectation of approximately two years to obtain regulatory approval before Project construction. This period allows sufficient time to achieve release from the environmental assessment process, which is followed by detailed project design and applications for construction and operating permits.

Initial processing plant construction is expected to require two to three years. As noted, the Proponent expects to begin with a smaller processing plant and expand operations as market conditions warrant. Construction on the marine terminal is expected to require approximately 11-13 months.

At this time, the expected operating life of the quarry is at least 50 years. Progressive reclamation will occur over the lifetime of the project, to extent this activity is possible within the active quarry. Closure, decommissioning, and final reclamation would follow the operating phase as is expected to require about two years.

### 5.5.2 Spatial Boundaries

Spatial boundaries are those geographic limits that help define the scale and range of the interactions between the Project and each VC. The spatial boundaries will also vary in accordance with each VC and so are presented in detail in each VC section. The following spatial boundaries are used for this assessment,

1. The **Project Area** (PA) is confined to all territory within the limits of the Project property boundary (**Figure 1.0-2**);
2. The **Affected Area** (AA) is the area which could potentially be affected by Project components or activities immediately beyond the PA. The Affected Area is similar to the area directly adjacent the Project property but can be larger depending on the component being considered.

The extent to which the AA is within the spatial boundaries of the Project is VC-specific and dependent on biological and physical considerations. For most VCs the AA is generally



within two kilometers of the Project property limit. Affected Area boundaries may be defined, for example, by habitat use of certain species, sub-watershed boundaries, and/or the predicted geographic extent of measureable air and noise emissions;

3. The **Study Area**: the Study Area (SA) is defined by considering all Project-environment interactions, including diffuse or longer range effects such as noise and light, which can only be modeled at this time. It may include, for example, the waters of Chedabucto Bay south of the shipping lanes where the Project-related marine activities and interactions will occur; for other VCs the SA may include the MODG where the majority of the social and economic effects can be expected.

Table 5-4 shows the spatial boundaries used to collect data during the baseline assessment phase of the environmental assessment, which in turn is applied to the effects assessment for each VC.

**Table 5.4:  
 Spatial Boundary Assessment by Valued Component**

Environment	Valued Component (VC)	Project Footprint	Adjacent Lands	Chedabucto Bay	MODG	Nova Scotia	Comment
Biophysical Environment	Air Quality and Climate Change	<input checked="" type="checkbox"/>	<input checked="" type="checkbox"/>			<input checked="" type="checkbox"/>	NS is addressed with respect to climate change; air quality is of local interest.
	Noise	<input checked="" type="checkbox"/>	<input checked="" type="checkbox"/>				AA is defined by the distance at which <b>excessive</b> noise effects are predicted.
	Ambient Light	<input checked="" type="checkbox"/>	<input checked="" type="checkbox"/>	<input checked="" type="checkbox"/>			AA is defined by the distance at which light trespass is predicted.
	Geology, Soil & Sediment Quality	<input checked="" type="checkbox"/>	<input checked="" type="checkbox"/>	<input checked="" type="checkbox"/>			Chedabucto Bay is included within AA.
	Groundwater Resources	<input checked="" type="checkbox"/>	<input checked="" type="checkbox"/>				AA extends to the limit of the groundwater drawdown cone at full quarry buildout.
	Marine and Surface Water Resources	<input checked="" type="checkbox"/>	<input checked="" type="checkbox"/>	<input checked="" type="checkbox"/>			Affected marine waters include those that may be affected through accidental or treated water discharges as well as Chedabucto Bay between the shore and shipping lanes transited by Project related vessels. Affected surface waters are defined through hydrological connectivity to the Project site.
	Terrestrial Species and Habitat, including SAR	<input checked="" type="checkbox"/>	<input checked="" type="checkbox"/>				AA is defined by sub-watershed boundaries, habitat range and ecological links as well as by the geographic extent of predicted noise & air quality effects; marine areas for this VC are addressed in relation to waterfowl, wintering birds, and marine birds.
	Freshwater Species and Habitat,	<input checked="" type="checkbox"/>	<input checked="" type="checkbox"/>				Sub-watershed boundaries are used to define AA
	Marine Species and Habitat, including SAR				<input checked="" type="checkbox"/>		AA is the marine terminal and vicinity and Chedabucto Bay between the shore and shipping lanes transited by Project related vessels.
	Wetlands	<input checked="" type="checkbox"/>	<input checked="" type="checkbox"/>				AA is defined through hydrological connectivity to the Project site.
Socio-Economic and Cultural Environment	Local Economy, Land and Resource Use	<input checked="" type="checkbox"/>	<input checked="" type="checkbox"/>	<input checked="" type="checkbox"/>	<input checked="" type="checkbox"/>	<input checked="" type="checkbox"/>	AA is generally taken as Half Island Cove, Upper Fox Island and Fox Island Main; PA is the MODG
	Tourism and Recreation	<input checked="" type="checkbox"/>	<input checked="" type="checkbox"/>	<input checked="" type="checkbox"/>	<input checked="" type="checkbox"/>		AA is generally taken as extending from Half Island Cove to Fox Island Main.

Commercial Fisheries and Aquaculture	<input checked="" type="checkbox"/> <input checked="" type="checkbox"/> <input checked="" type="checkbox"/>	PA includes the zoned fished by local fishermen who generally reside from Guysborough to Canso but may include fishermen from outside this area
Aboriginal Land and Resource Use	<input checked="" type="checkbox"/> <input checked="" type="checkbox"/> <input checked="" type="checkbox"/> <input checked="" type="checkbox"/>	. AA includes all areas that could be affected by the Project (e.g., through noise, light, dust etc) and are potentially used by Aboriginal peoples for traditional purposes. Spatial boundaries are defined in relation to health and socio-economic conditions for Aboriginal peoples
Archaeological & Heritage Resources	<input checked="" type="checkbox"/>	PA is confined to those areas disturbed by the Project

SAR = Species at Risk; MODG = Municipality of the District of Guysborough

### 5.5.3 Technical Boundaries

Technical boundaries represent limits to the Project team’s ability to assess a VC, pathway or receptor. A technical boundary is a theoretical or actual limitation on the ability to measure, assess, and/or monitor potential environmental effects. These data gaps may in turn limit the ability to predict the potential effects of the Project on a particular VC. The EA methodology requires that these data gaps, if present, be described along with the steps taken to address the gaps (CEA Agency 2014).

### 5.5.4 Administrative Boundaries

Administrative boundaries are those limits that originate through regulatory, public policy or economic reasons. Administrative boundaries include, for example, the regulatory requirements as described in Section 2.0, the physical boundaries of wildlife sanctuaries, the different NAFO Division and Unit (fishing) Areas, and the temporal boundaries of hunting, fishing or trapping seasons. Where applicable, administrative boundaries are described in each VC chapter (Section 7.0)

## 5.6 Impact Prediction

Ultimately, an environmental assessment aims to determine whether a given project is “likely to cause significant adverse environmental effects”; these terms are defined in the reference CEA Agency (1994). As noted above, the environmental effects assessment consists of a series of steps beginning with the identification of the VCs. Following identification, the “baseline” or existing condition of each VC type is studied and described. Once the existing condition for each VC is known, the environmental assessment:

1. Predicts the adverse Project-related environmental effects or impacts and evaluates the scope and scale of these effects;
2. Describes a number of mitigation measures and practices that the Proponent will use to avoid, minimize, eliminate, mitigate, or compensate for the effects;

3. Predicts residual adverse environmental effects after mitigation but before the assessment of the cumulative effects described below.
4. Assesses the cumulative effects from other probable (i.e., certain and reasonably foreseeable) future projects, taking into consideration past and current projects; and
5. Determines the residual adverse effects remaining after mitigation and assesses the significance of these effects on each VC. This step also includes consideration of the cumulative effects described above.

## **5.7 Environmental Effects Assessment**

As noted, the manner in which a project may affect the VCs is a function of the linkage or pathway from one to the other. The environmental effects of a project are a function of its activities, while the pathways are a function of several things, including project activities, ecological systems, and contaminant properties. Typically, the assessment uses provincial and federal guidelines and policies to determine potential pathways and effects, combined with computer or numerical modeling, knowledge of the site conditions and professional judgment. Other information sources include input from experts, stakeholders, and regulators; experience from previous environmental assessments; primary scientific literature.

## **5.8 Mitigation and Residual Effects**

The next step in the environmental assessment determines the potential residual adverse environmental effects by Project phase. Residual adverse effects are derived using a three-step process:

1. Determine the potential interactions between the VCs and Project activities, for each Project phase, and the environmental effects of these interactions in combination with those from other likely future projects;
2. Assess the effect of the mitigation strategies applicable to each of the interactions; and
3. Characterize the nature and extent of the remaining, residual environmental effects after mitigation measures have been applied. That is, determine their “significance” and “likelihood”.

Environmental effects assessment matrices have been used to summarize the analysis of environmental effects (see Table 5-5 for an example). Cumulative environmental effects and potential impacts occurring from accidents, malfunctions and unplanned events are described in separate sections. This allows for a comprehensive analysis of all Project-VC interactions. Supporting discussion in the accompanying text highlights particularly important relationships, site data and assessment results.

A great variety of mitigation measures are available for most projects. These measures range from the use of standard industry best management practices for construction and operation, through training and sensitization of site workers, to site-specific design features that can be applied to limit or eliminate a particular effect. Based on the Proponent’s extensive experience with the potential environmental effects of aggregate production, a number of mitigation



measures were incorporated into the Project design and implementation plan in order to minimize potential adverse effects. In addition, mitigation measures can include environmental protection strategies, environmental management systems, and compensation projects, as noted in the EIS Guidelines, mitigation measures must be technically and economically feasible. Mitigation measures are described in each VC assessment chapter of Section 7.0.

**Table 5.5:  
 Residual Environmental Effects Assessment Matrix for [Name of VC]**

Project Environment Interaction	Potential Residual Environmental Effects A=Adverse P= Positive	Mitigation	Magnitude	Geographic Extent	Duration / Frequency	Reversibility	Ecological / Socio-Economic Context	Residual Effect	Significance of Residual Effect
<b>Construction</b>									
Activity 1									
Activity 2									
<b>Operation</b>									
Activity 1									
Activity 2									
<b>Decommissioning</b>									
Activity 1									
Activity 2									
<b>Legend</b>									
<u>Magnitude (see Table 5.6):</u>		<u>Geographic Extent:</u>		<u>Frequency:</u>		<u>Ecological / Socio-Economic Context:</u>			
U= Unknown		1 = < 1 km <sup>2</sup>		1 = < 11 events/year		1 = Relatively pristine area or area not adversely affected by human activity.			
0 = Nil		2 = 1 – 10 km <sup>2</sup>		2 = 11 – 50 events/year		2 = Evidence of adverse environmental effects.			
1 = Low		3 = 11 – 100 km <sup>2</sup>		3 = 51 – 100 events/year		N/A = Not applicable			
2 = Medium		4 = 101 – 1,000 km <sup>2</sup>		4 = 101 – 200 events/year		A = Adverse			
3 = High variation)		5 = 1,001 – 10,000 km <sup>2</sup>		5 = > 200 events/year		P = Positive			
		<u>Duration:</u>		6 = continuous					
		1 = < 1 month		<u>Reversibility:</u>					
		2 = 1 – 12 months		R = Reversible					
		3 = 13 – 36 months		I = Irreversible					
		4 = 37 – 72 months							
		5 = > 72 months							

The legend is typical for biological VCs and is provided for illustrative purposes only. The legend may vary from VC to VC as appropriate.

The prediction of residual effects follows three general steps (CEA Agency 1994):

- Determining whether the environmental effects are **adverse**;
- Determining whether the adverse environmental effects are **significant**; and
- Determining whether the significant adverse environmental effects are **likely** to occur.

Some of the key factors that must be considered in determining *adverse* environmental effects are given in the CEA Agency's guidance document (CEA Agency 1994). This guidance was used when applying Table 5.5 to each VC:

- Negative environmental effects on the health of biota;
- Loss of rare or endangered species;
- Reduced biological diversity;
- Loss or avoidance of critical / productive habitat;
- Habitat fragmentation or interruption of movement corridors and migration routes;
- Transformation of natural landscapes;
- Chemical discharge;
- Loss or detrimental change in current use of lands and resources for traditional purposes;
- Foreclosure of future resource use or production;
- Adverse environmental effects on human health or well-being;

## 5.9 Residual Effects and the Determination of Significance

Residual impacts are those environmental effects predicted to remain after the mitigation measures have been applied or implemented. The predicted residual effects are considered for each Project phase (construction, operation, and decommissioning) and for potential accidental events. The *significance* of these residual effects to the local and regional areas is evaluated by assessing those criteria outlined in guidance documents provided by the CEA Agency (1994):

- **Magnitude:** the amount or degree of change in a measurable parameter or variable relative to existing conditions. It refers to the severity of the adverse environmental effect after mitigation.
- **Geographic Extent:** the area over which the adverse effect is predicted to occur after mitigation.
- **Duration:** the period of time over which the adverse effect will occur following mitigation.
- **Frequency:** the number of times during the Project that an effect might occur (e.g., one time or multiple times).
- **Reversibility:** the likelihood that a VC will recover from an adverse environmental effect, including consideration of reclamation, restoration, compensation and offset programs. Reversibility is considered on a population level for biological VCs: while

a severe effect like mortality is irreversible at the individual level, the environmental effect on the population may be reversible.

- **Ecological or Social Context:** the general setting of the area where the Project is located, as indicated by existing levels of human activity and associated disturbance.

The magnitude or severity of an adverse Project effect can be difficult to ascertain in some cases. To help assess magnitude, a relative rating was used, based on that used for other recent projects in the area (Table 5-6).

With respect to geographic extent, frequency, and duration, the environmental assessment employed defined or absolute values for these parameters, as described in each VC section.

**Table 5.6:  
 Definitions for Levels of Magnitude**

Rating	Magnitude*
High	An environmental effect affecting a whole ecological population or group of people, or where the effect or parameter is outside the range of natural variability determined from local knowledge over many seasons.
Medium	An environmental effect affecting part of a population, or one or two generations, or where there are rapid and unpredictable changes in an effect or parameter so that it is temporarily outside the range of natural variability determined from local knowledge over many seasons.
Low	An environmental effect affecting a specific group of individuals in a population in a localized area, one generation or less, or where there are distinguishable changes in a specific parameter; however, the parameter is within the range of natural variability determined from local knowledge over many seasons.
Nil	No environmental effect.
Unknown	An environmental effect affecting an unknown portion of a population or group or where the changes in a specific parameter are unknown.

(source: modified from AMEC 2013).

\*Note: Definitions for magnitude for air and water quality are specific and addressed separately in their respective chapters in Section 7.0.

To determine the likelihood of significant adverse residual effects, the assessment considers *probability* of occurrence and the *scientific uncertainty* regarding the information used in the impact assessment.

### 5.10 Cumulative Environmental Effects

Cumulative environmental effects are residual project effects combined with the environmental effects of future projects and/or activities.

For the Black Point environmental assessment, the descriptions of the existing environment and of the current condition of each VC already includes the effects other past and current projects occurring within the Project Area. The assessment assumes that these existing projects will continue in the future and will have similar effects as are currently observed. The assessment has, therefore, integrated the cumulative effects of these ongoing projects and activities.



The cumulative effects assessment presented in Section 9.0 thus focuses on the effects of future projects and activities. This is consistent with guidance documentation developed by the CEA Agency: “temporal boundaries...should take into account future physical activities that are certain and reasonably foreseeable, and the degree to which the environmental effects of these physical activities will overlap those predicted from the designated project” (CEAA 2013).

### **5.11 Follow Up and Monitoring**

“Follow-up” is a process that verifies the accuracy of the predicted impacts and determines the effectiveness of the measures taken to mitigate the adverse environmental effects.

A series of follow-up programs will be developed for the Black Point Quarry Project; these programs are outlined in Section 10. The elements of the programs will be developed through consideration of each VC, and where appropriate or warranted, follow-up measures will be taken.

In addition to follow-up programs pursuant to requirements of *CEAA 2012*, the Proponent will also evaluate the need for monitoring required to ensure regulatory or corporate compliance, and commitments to third parties. To help achieve the goal cause of preventing “serious or irreversible harm to the environment” as required by the EIS Guidelines (CEA Agency 2014), the proponent will implement environmental management and contingency plans to prevent or address situations during construction, operations and decommissioning that may result in accidents or malfunctions and lead to unexpected effects.

### **5.12 Effects of the Environment on the Project**

The effects of the environment on the Project (i.e., severe weather, earthquakes, etc.) have also been taken into consideration. Project activities and infrastructure were reviewed for interactions with the natural environment, including wind, waves, ice and extreme precipitation events. Project plans and activities have been designed to reflect the limitations imposed by the natural environment. A significant effect of the environment on the Project is one that:

- Harms Project personnel or the public;
- Results in a substantial delay in construction (e.g., more than one season) or shutdown of operations;
- Damages infrastructure and compromises public safety; and
- Damages infrastructure to the extent that repair is not economically or technically feasible.

The effects of the environment on the Project are assessed in Section 8.0. Where effects of the environment on the Project can in turn result in effects to the environment (e.g., an oil spill could result from weather or ice conditions), this is addressed in the environmental assessment for each of the VCs. In the case of an accidental event, the worst case scenario event, regardless of the cause, has been assessed for each VC (Section 7.18).

### **5.13 Description of the Retained VCs**

Tables 5.2 and 5.3 demonstrate that the provisional VCs identified in the scoping exercise can be potentially affected by the Project through a variety of pathways. This section describes the nature of each VC in more detail and provides a rationale for its selection.

#### **Air Quality and Climate Change**

Air quality concerns associated with the generation of dust have been raised by community residents and the Mi'kmaq, and so Air Quality is identified as a VC. Air quality within the Project site is regulated by the province through the *Workplace Health and Safety Regulations*, which establishes the air quality conditions needed to maintain worker health. Air quality is also a pathway to food chain via the transport of dust and deposition of contaminants on vegetation and surface water. Air quality outside of the Project site is also regulated by the province, which sets air quality emissions standards for industrial operations. Greenhouse gas (GHG) emissions are associated with climate change and have been the subject of provincial regulation and policy initiatives. Vehicles used at the Project site will produce GHGs from the combustion of fuel.

#### **Noise**

Activities such as blasting and aggregate processing will undoubtedly produce noise and have the potential to alter the ambient noise conditions of the local area. Noise concerns have been raised by residents living to the east and west of the Property. Changes to ambient noise may also affect a variety of wildlife, migratory birds and SAR. Noise associated with quarry activities is regulated by the province.

Construction of the marine terminal will likely result in temporary increases to noise in the marine environment, which in turn may affect nearby marine biota. Noise may alter the behaviour patterns of certain marine species, which may in turn affect these species at different times of their life cycles. Shipping associated with the marine terminal will add to the noise already present in the marine environment.

#### **Ambient Light**

Since the Project site is currently undeveloped, night time ambient light conditions are low. As the site is developed into a quarry, artificial light will be introduced in the form of vehicle headlights, work area illumination, and lights installed on the marine terminal to ensure safe navigation. Changes to ambient light conditions have the potential to negatively affect wildlife in the immediate area and birds from further afield. Increases in night time light levels may also be perceived as a nuisance by local residents.

#### **Bedrock Geology and Sediment**

The Project site is currently undeveloped, although historical records suggest at least three families inhabited areas near the coast in the past. Despite this, there is no evidence to suggest that contaminated soils or sediment are present on the site. Bedrock geology and sediment was selected as a VC primarily due to the presence of Halifax Formation rocks which underlay a small portion of the site near the coast. The rocks have the potential to generate acid runoff

when excavated and exposed to oxygen. Excavation of these rocks will be required in preparation for the installation of the processing plant and aggregate stockpiles.

Sedimentation in the marine environment has been identified by fishermen and nearby coastal residents as a potential concern, since the discharge or runoff of sediment-laden water during construction and operation may have harmful effects on nearby lobster habitat. In addition, residents and fishermen have expressed concern regarding the transport of suspended sediment along the shore and into neighbouring bays.

### **Groundwater Resources**

Groundwater extracted from dug and drilled wells is used for drinking water by the nearest residents living to the east, west and south of the Project. In addition, groundwater can play an important role in sustaining streams and wetlands and the habitats and wildlife that depend on them. The Project will remove granite from below the water table, which in turn will affect the local groundwater table. Project activities are perceived by nearby residents to have the potential to affect groundwater supply and quality within their wells. Groundwater is also a potential pathway that can transport contaminants offsite. Groundwater quality is regulated by the province.

### **Marine and Surface Water Resources**

As noted previously, marine water quality may be negatively affected by sediment laden water in the form of discharge or stormwater runoff. Acid rock drainage generated from the disturbance of Halifax Formation rocks may also affect marine water quality. Good quality water is essential to the well being of a large variety of organisms, from the smallest algae to large marine mammals. Marine water quality is also critical to the long term success and sustainability of the commercial fishery, which is a vital economic and social activity in the county and beyond. Marine water quality is regulated by the federal government, which is also responsible for managing and permitting the navigational aspects of the marine terminal.

Surface water quality and quantity play an important role in maintaining ecosystem health in downstream receptors, and surface water can transport contaminants off-site. Surface water can recharge groundwater and thus can act as a pathway for the transport of contaminants to the subsurface in the case of an on-site spill. Surface water is not used for drinking water purposes in the immediate Project area, but the project will use, treat and potentially discharge surface water during the course of operations. In addition, surface water quality may potentially be affected by accidental spills, fires or other events on the property. Surface water quality is regulated by the province.

### **Terrestrial Ecosystems, Habitat & Vegetation**

Terrestrial ecosystems habitat and vegetation express local and regional biodiversity and support ecological resilience. These features form the basis upon which local wildlife populations depend. Terrestrial ecosystems and habitat will be permanently diminished or destroyed, and vegetation will be lost during the course of building and operating the Project. Mi'kmaq has expressed concerns with respect to their continuing ability to harvest terrestrial resources within the Project and adjacent areas, as well as the overall effect of Project activities

on ecological resources in general. Indirect impairments to ecosystems and habitat may occur through Project-related activities such as water use and dust emissions.

### **Wetlands**

Wetlands are highly productive and diverse ecosystems that perform a number of biophysical and ecological functions. They may provide habitat or refuges for a diversity of species, including SAR, attenuate storm flows, recharge groundwater and provide discharge to downstream receptors during dry periods. Over the 50 year life of the Project, development will directly affect a number of wetlands on the Project site, and may indirectly affect others through effects to surface and groundwater flows. These effects will not be felt at once, but rather progressively as the quarry expands over its 50 year production life. Wetlands are regulated by the province.

### **Terrestrial Wildlife**

Terrestrial wildlife species have ecological, aesthetic and recreational importance to the public and First Nations, primarily as a food source and as an economic and recreational resource. Project development will impair or eliminate the productive capacity of some terrestrial habitat within the Project footprint. Other indirect interactions (airborne dust, emissions, noise, vibration, light, water use) may affect species and habitat adjacent to the Project. Most terrestrial species and habitat are regulated by the Province but migratory birds are regulated at the Federal level.

### **Freshwater Species and Habitat**

The creeks and lakes on the Property and in the immediate vicinity support important terrestrial habitat types and a number of aquatic species, but do not contain fish due to their acidity. Nevertheless, freshwater species and habitat are important biological components of larger ecological systems and are valued by the public and the Mi'kmaq. Project activities will destroy small areas of freshwater habitat (and may damage or impair other areas) but the Project will ultimately create considerably more freshwater habitat than currently exists on the site.

### **Marine Species and Habitat**

Marine species and their habitat are valued for the aesthetic, cultural, ecological and economic attributes by First Nations and the public at large. Construction of the marine terminal will permanently destroy sea bottom habitat even as new habitat is created by the terminal foundations. To offset this habitat loss, habitat creation nearby is required by DFO. Transport of aggregate via seagoing vessels will impact upon the marine environment through noise associated with vessel passage and potentially through accidental spills or other incidents at sea. Marine SAR are of interest to scientists, regulators and public due to their inherent biological and cultural value and are protected under federal provincial legislation. Fish and fish habitat in general is regulated by DFO at the federal level.

### **Species at Risk**

Species at Risk are identified as a VC due to their ecological role, scientific value and cultural attributes. Species at Risk may be regulated at the federal level, the provincial levels, or both. The direct loss of habitat used by terrestrial or marine SAR is the primary concern of this VC,



although SAR may be indirectly affected through noise, light and general activity at the Project site.

### **Local Economy, Land and Resource Use**

Economic effects of the Project are of interest to local residents, municipal officials and the provincial government. Nearby residents gain their living through forestry, commercial fishing, tourism, government and service occupations. Project revenues or royalties that flow to the MODG and Project expenditures may positively affect local economies. The Project will also contribute to the municipal tax base. Regional economic improvements can affect the population size and demographics as workers move to the area, purchase property, goods and services, and raise families. Property values can also be affected by large scale project development.

Employment and business opportunities are valued by people who may benefit directly from income generated by the Project and/or indirectly from newly needed services. The Project will require a temporary labour force during construction and a smaller but significant labour force over the long term operation of the Project. In addition to direct hires, the Project will generate employment and economic activity through contracting for goods and services.

### **Existing and Planned Land Uses**

A major development such as the proposed Project can affect existing as well as planned land uses. Current on-site land uses (trapping, local tourism) will be replaced by quarrying and associated activities. Existing and planned land uses on adjacent properties may be impacted through changes to the visual or acoustic environments. Land use is regulated by the Province and through municipal zoning and land use bylaws.

### **Tourism and Recreation**

Residents and tourists alike make use of the local terrestrial and marine resources for outdoor activities such as camping, hiking, fishing, boating, off-road motoring, and hunting. These activities are popular and to a certain degree, available, due to the largely undeveloped nature of the area. The presence of quarry may influence perceptions regarding noise and changes in the visual character of the coastal landscape, resulting in changes to recreational resource use patterns. The Project may result in restrictions to currently accessible beaches and headlands at the Project site. Navigability of water courses and coastal waters is regulated by federal legislation.

### **Commercial Fisheries and Aquaculture**

Marine commercial fisheries represent an important, sustainable resource of historical, cultural, social and economic value to local communities and the Mi'kmaq. As noted, there are no freshwater commercial or recreational fisheries on the Property. Aquaculture is not currently practiced along the south shore of Chedabucto Bay.

The marine terminal will result in limitations to lobster harvesting in the immediate area of the marine terminal and, as result, displacement of those who currently fish in the nearshore at the Black Point site into other areas. The transit of empty and loaded aggregate transport ships has

the potential to interfere with other commercial fishing activities that occur in deeper water between the shipping lanes and the south shore of Chedabucto Bay.

Accidental spills or discharges to the aquatic environment can alter water quality and physical habitat, which in turn can affect life-cycle stages of commercially important species and their food supply.

Fish harvesting is regulated by the Federal Government under the *Fisheries Act*.

### **Archaeological and Heritage Resources**

Post-European contact heritage resources are found on the property near the coast where historical homesteads were established over the course of several generations. Archaeological and Heritage Resources were identified in the EIS Guidelines as a potential VC and concerns have been raised regarding the possible existence of these resources during the public outreach phase of the environmental assessment. Although a 30 m buffer zone will be left undisturbed along the coastline to protect some of these finds, much of the coastal zone inside this buffer will be built upon, thus disturbing, destroying or covering over some of these resources. Archaeological and Heritage Resources are protected through provincial legislation.

### **Aboriginal Land and Resource Use**

Aboriginal culture in the form of traditional land and resource use is practiced on a regular basis by the Mi'kmaq community. Traditional hunting, fishing, and plant harvesting practices are deeply rooted and highly valued in these communities. Mi'kmaq land and resource use could be affected by the Project through the loss of access to or alteration of harvesting areas and traditionally use lands. Overarching Mi'kmaq land claims can affect the establishment of clear title to land designated for industrial development. Legal jurisprudence has defined federal and provincial responsibilities with respect to Aboriginal peoples and the settlement of outstanding land claims. Consideration of Aboriginal interests is legislated by federal and provincial laws and listed in the EIS Guidelines issued for this Project.